

# Advanced Energy Design Guide for Small Office Buildings

This is an ASHRAE Design Guide. Design Guides are developed under ASHRAE's Special Publication procedures and are not consensus documents. This document is an application manual that provides voluntary recommendations for consideration in achieving greater levels of energy savings relative to minimum standards.

### **SPECIAL PROJECT 102 COMMITTEE**

Ron Jarnagin, *Chair*

Don Colliver  
*Cognizant Committee Ex Officio*

Joe Deringer  
*AIA Representative*

Jim Edelson  
*NBI Representative*

Jay Enck  
*ASHRAE TC 2.8 Representative*

Michael Lane  
*IESNA Representative*

Merle McBride  
*ASHRAE At-Large Representative*

Hayden McKay  
*IESNA Representative*

Harry Misuriello  
*ASHRAE TC 7.6 Representative*

Daniel Nall  
*AIA Representative*

Don Steiner  
*ASHRAE SSPC 90.1 Representative*

Donna Leban  
*AIA Representative*

Bruce Hunn  
*Staff Liaison*

### **COGNIZANT COMMITTEE**

Don Colliver, *Chair*

Ed Jackson  
*AIA Representative*

Rita Harrold  
*IESNA Representative*

Jeff Johnson  
*NBI Representative*

Terry Townsend  
*ASHRAE ExCom Representative*

Mark Case  
*ASHRAE TC 2.8 Representative*

Ron Majette  
*DOE Representative*

Adam Hinge  
*ASHRAE TC 7.6 Representative*

Jerry White  
*ASHRAE SSPC 90.1 Representative*

Ron Jarnagin  
*SP-102 Chair – Ex Officio*

Bruce Hunn  
*Staff Liaison*

# Advanced Energy Design Guide for Small Office Buildings

Achieving 30% Energy Savings Over ANSI/ASHRAE/IESNA Standard 90.1-1999

American Society of Heating, Refrigerating and Air-Conditioning Engineers, Inc.  
The American Institute of Architects  
Illuminating Engineering Society of North America  
New Buildings Institute  
United States Department of Energy

ISBN 1-931862-55-9

Library of Congress Control Number: 2004110374

©2004 American Society of Heating, Refrigerating  
and Air-Conditioning Engineers, Inc.  
1791 Tullie Circle, N.E.  
Atlanta, GA 30329  
www.ashrae.org

All rights reserved.

Printed in the United States of America

Cover design by Pamela del Canto, The American Institute of Architects.  
Cover drawing by Richard J. Vitullo, The American Institute of Architects.  
Reprinted from *Architectural Graphic Standards*, Tenth Edition,  
with permission of John Wiley & Sons, Inc. Copyright © 2000.

ASHRAE has compiled this publication with care, but ASHRAE has not investigated, and ASHRAE expressly disclaims any duty to investigate, any product, service, process, procedure, design, or the like that may be described herein. The appearance of any technical data or editorial material in this publication does not constitute endorsement, warranty, or guaranty by ASHRAE of any product, service, process, procedure, design, or the like. ASHRAE does not warrant that the information in the publication is free of errors, and ASHRAE does not necessarily agree with any statement or opinion in this publication. The entire risk of the use of any information in this publication is assumed by the user.

No part of this book may be reproduced without permission in writing from ASHRAE, except by a reviewer who may quote brief passages or reproduce illustrations in a review with appropriate credit; nor may any part of this book be reproduced, stored in a retrieval system, or transmitted in any way or by any means—electronic, photocopying, recording, or other—without permission in writing from ASHRAE.

---

## ASHRAE STAFF

### SPECIAL PUBLICATIONS

**Mildred Geshwiler**

*Editor*

**Erin Howard**

*Associate Editor*

**Christina Helms**

*Associate Editor*

**Michshell Phillips**

*Secretary*

### AIA STAFF

**Janet Rumbarger**

*Director of Editorial Services*

### PUBLISHING SERVICES

**Barry Kurian**

*Manager*

**Jayne Jackson**

*Production Assistant*

### PUBLISHER

**W. Stephen Comstock**

**Pamela Del Canto**

*Director of Design Services*

**Sybil Walker Barnes**

*Editor/Writer*

# Contents

## **Acknowledgments • VII**

### Chapter 1 **Introduction • 1**

### Chapter 2 **Integrated Process to Achieve Energy Savings • 3**

Pre-Design Phase—Prioritize Goals 4

Design Phase 8

Construction 9

Acceptance 9

Occupancy 10

Operation 10

### Chapter 3 **Recommendations by Climate • 15**

Zone 1 18

Zone 2 22

Zone 3 26

Zone 4 30

Zone 5 34

Zone 6 38

Zone 7 42

Zone 8 46

### Chapter 4 **How to Implement Recommendations • 51**

Quality Assurance 51

Envelope 57

Opaque Envelope Components 57

Vertical Glazing (Envelope) 65

Window Design Guidelines for Thermal Conditions 66

Window Design Guidelines for Daylight 69

Lighting	71
Daylighting	71
Daylighting Controls	73
Electric Lighting Design	75
HVAC	80
Service Water Heating	89
Bonus Savings	91
Plug Loads	91
Exterior Lighting	92

Appendix A **Envelope Thermal Performance Factors • 95**

# Acknowledgments

The primary contributors to the Advanced Energy Design Guide were the 13 members of the ASHRAE Special Project 102 Committee (SP-102) representing the various participating organizations that worked collaboratively to produce this document. While the document was produced under the organizational mantle of ASHRAE, much of the heavy lifting was done by representatives of the ASHRAE technical and standards project committee members, the American Institute of Architects (AIA), the Illuminating Engineering Society of North America (IESNA), the New Buildings Institute (NBI), and the United States Department of Energy (DOE). Within ASHRAE special thanks go to members of Standing Standards Project Committee 90.1 (SSPC 90.1), the Technical Committee on Building Environmental Impact and Sustainability (TC 2.8), and the Technical Committee on Systems Energy Utilization (TC 7.6) for the participation of their representatives on the SP-102 committee.

No document of this type and scope, with a very limited timeline and with a diverse group of collaborating partners, would have been possible without the firm guidance provided by the members of the Cognizant Committee. Without the vision for this document provided by 2002-2003 ASHRAE President Don Colliver as part of his presidential theme speech, as well as his steady hand as chair of the Cognizant Committee, this document would likely not have been produced. The well-focused scope and purpose for the Advanced Energy Design Guide developed by the Cognizant Committee provided a clear roadmap for the SP-102 committee to follow in producing the document in a timely manner.

During the eight-month development cycle of this document, the SP-102 committee conducted three review periods designed to gain input at the concept stage, the technical refinement stage, and the final stage of the document. Many comments were received from members of the partner organizations, as well as from others in the HVAC&R and energy efficiency communities, all of which helped to make the document better. The committee carefully assembled and considered all of these comments and made their best attempt to incorporate them where appropriate. In addition, ASHRAE convened a focus group made up of designers, consulting engineers, and contractors that provided valuable input into the document format and content. Many of their ideas are represented in the current Guide.

The chairman wishes to specifically thank the ASHRAE representatives on the committee for their willingness to put their shoulders into the job and get it done, the AIA representatives for their constant pushing to make the document more user friendly for those in the design community, the IESNA representatives for their professionalism and for again demonstrating the value of their longstanding partnership with ASHRAE in developing energy efficiency documents, the NBI representatives for their insights drawn from having plowed some of this ground already, the many ASHRAE TC and SSPC members who contributed in so many ways to the document, and to the DOE for its generous support of the project. And finally, special thanks go to Bing Liu of Pacific Northwest National Laboratory for her passion and dedication in producing well-documented simulation runs and timely energy savings results that allowed the committee to make the key decisions necessary to bring this project to a successful conclusion.

Preparation of this Design Guide was a high priority for each of the partner organizations. Perhaps one of the most important criteria was the issue of timeliness of the document. An aggressive development schedule was developed and adhered to, which frequently took its toll on the members of the committee as well as the external reviewers. However, the committee members responded to the challenge with an unprecedented spirit of cooperation that allowed the project to be completed successfully. From the initial organizational meeting of the project committee to a final approved document in eight months, all done with volunteer labor, ASHRAE and its partners helped prove that ASHRAE can operate at the speed of business!

As chairman of the committee I would like to say that I am extremely proud of the effort and the results put forth by the committee and commend each and every one of them for the Herculean effort in producing this Guide.

Ron Jarnagin  
SP-102 Chair  
October 2004



# Introduction

# 1

The *Advanced Energy Design Guide for Small Office Buildings* (Guide) is intended to provide a simple approach for contractors and designers who create office buildings up to 20,000 ft<sup>2</sup>. Application of the recommendations in the Guide should result in small office buildings with 30% energy savings when compared to those same office buildings designed to the minimum requirements of ANSI/ASHRAE/IESNA Standard 90.1-1999. This document contains recommendations and *is not* a minimum code or standard. It is intended to be used *in addition to* existing codes and standards and is not intended to circumvent them. This Guide represents *a way*, but *not the only way*, to build energy-efficient small offices buildings that use significantly less energy than those built to minimum code requirements. The recommendations in this Guide provide benefits for the owner while maintaining quality and functionality of the space.

This Guide has been developed by a committee representing a diverse group of energy professionals drawn from the American Society of Heating, Refrigerating and Air-Conditioning Engineers (ASHRAE), the American Institute of Architects (AIA), the New Buildings Institute (NBI), and the Illuminating Engineering Society of North America (IESNA). To quantify the expected energy savings, these professionals selected potential envelope, lighting, HVAC, and service water heating energy-saving measures for analysis. These included products that were deemed to be both practical and commercially available. Although some of the products may be considered premium, products of similar performance are available from multiple manufacturers. Each set of measures was simulated using an hour-by-hour building energy analysis computer program for two small office prototypes in representative cities in various climates. Simulations were run for reference buildings (buildings designed to Standard 90.1-1999 criteria) compared to buildings built using recommendations contained in this Guide to determine that the expected 30% savings target was achieved.

The scope of this Guide covers small office buildings up to 20,000 ft<sup>2</sup> in size that use unitary heating and air-conditioning equipment. Buildings of this size with these HVAC system configurations represent a large fraction of commercial office space in the United States. This Guide provides straightforward recommendations and “how-to” guidance to facilitate its use by anyone in the construction process who wants to produce more energy-efficient buildings.

As an added value for designers and contractors, this Guide features examples of energy efficient buildings appropriate for each climate zone. The examples demonstrate that effectively addressing environmental challenges can also result in the creation of good, often excellent, architecture. The examples were selected from the American Institute of Architects' annual Top Ten Green Projects competition winners, the Department of Energy's High Performance Buildings Database, and individual project architects. The examples illustrate how energy considerations have been incorporated in various design strategies and techniques. However, the example buildings may incorporate additional features that go beyond the scope of the recommendations of the Guide. The result of the Guide, it is hoped, will be a better built environment for society.

## HOW TO USE THIS GUIDE

Chapter 2 of this Guide contains a chart that walks the user through the design process of applying the recommendations in this Guide, while chapter 3 provides the actual recommendations for a way to meet the 30% energy savings goal. Chapter 3 consists of eight recommendation tables, which are broken down by building component and organized by climate according to the eight climate zones identified by the U.S. Department of Energy. The user should note that the recommendation tables do not include all of the components listed in Standard 90.1 since the Guide focuses only on the primary energy systems within a building. Chapter 3 is illustrated with the examples provided by AIA. Chapter 4 provides essential guidance in the form of concise “how-to” tips to help the user to understand and apply the recommendations from this Guide. In addition, this Guide provides recommendations that would assist the user in achieving energy efficiency credits for LEED™ or other building energy rating systems.

This Guide includes specific recommendations for energy-efficient improvements in the following technical areas to meet the 30% goal:

- Building Envelope
  - Roofs
  - Walls
  - Floors
  - Slabs
  - Doors
  - Vertical Glazing
  - Skylights
- Lighting
  - Daylighting
  - Interior Electric Lighting
  - Controls
- HVAC Equipment and Systems
  - Cooling Equipment Efficiencies
  - Heating Equipment Efficiencies
  - Supply Fans
  - Ventilation Control
  - Ducts
- Service Water Heating
  - Equipment efficiencies
  - Pipe insulation

In addition, “Bonus Savings” strategies to improve energy efficiency beyond the 30% are included for:

- Exterior Façade Lighting
- Parking Lot Lighting
- Plug Loads

Quality assurance and commissioning are also covered in chapter 4.

# Integrated Process for Achieving Energy Savings

# 2

This chapter of the Guide provides resources for its users who want to understand and adopt an overall *process* for designing, constructing, and operating energy-efficient buildings. These resources are above and beyond the straightforward presentation of recommendations in chapter 3 and “how-to” tips in chapter 4 that lead to energy savings of 30 percent beyond Standard 90.1-1999.

The following presentation of an integrated process for achieving energy savings in small office buildings is valuable for designers and builders who want to augment and improve their practices so that energy efficiency is deliberately considered at each stage of the development process from project conception through building operation. These stages are shown in Figure 2-1.

The key benefits of following this integrated process include:

- Understanding the specific step-by-step activities that design and construction team members need to follow in each phase of the project's delivery including communication of operation and maintenance requirements an owner should follow to maintain energy performance of the facility.
- Developing the capability to identify energy efficiency goals and to select design strategies to achieve those goals.
- Incorporating quality assurance (i.e., building commissioning) procedures into the building design and delivery process to ensure that energy savings of recommended strategies are actually achieved and that specific information needed to maintain energy performance is provided to the owner.
- Owner understanding of the responsibilities needed to help ensure continued energy performance for the life of the facility, resulting in lower total cost of ownership.

This chapter provides users of this Guide with the following resources:

- *A narrative discussion of the design and construction process that points out the opportunities for energy savings in each phase.* It further explains the steps that each team member or discipline should take to identify and implement energy savings concepts and strategies. It also includes a discussion on how the quality assur-



**Figure 2-1.** Stages of design.

ance measures are worked into the process at each phase and how some of these measures can be used by the owner to maintain energy performance for the life of the facility.

- *A reference table or matrix that leads the Guide’s user through the process of identifying and selecting energy savings measures to meet major energy design goals.* This information is presented in Table 2-1, which ties together detailed strategies, recommendations to meet the 30 percent energy use reduction target, and related “how-to” information.

Users of this Guide are encouraged to study this recommended process and determine if their design and construction practice could benefit from its use.

## **1. PRE-DESIGN PHASE—PRIORITIZE GOALS**

Document the adopted energy goals and general strategies in the Pre-Design phase. These will guide the team and provide a benchmark during the design and construction of the project.

Emphasize goals that relate to large energy uses that can produce the largest savings. Priorities of the goals may change greatly from one climate to another and from one building to another. For example, differences in building orientation can have profound impacts on the selection of various energy goals and strategies. Likewise, climate variation can strongly influence the goal priorities. As an example, Figures 2-2 and 2-3 show energy use mixes for a 5,000 ft<sup>2</sup> office building in two locations, one in Miami and one in Duluth, Minn. Both of these buildings use gas for space heating and water heating. These charts demonstrate that cooling and lighting energy predominates in Miami; thus the goals and strategies relating to cooling and lighting should receive the highest priority. Conversely, in Duluth the goals and strategies relating to heating and lighting should receive the highest priority.

Table 2-1 (page 11) presents four goals, along with specific strategies for achieving energy savings in new construction. Reducing loads (Goal 1) both internal and external is the most basic. Matching the capacity of energy-using systems to the reduced loads (Goal 2) is also important. Oversized systems cost more and do not operate at their optimum efficiency. Higher efficiency equipment (Goal 3) will use less energy to meet any given load. Thus, high-efficiency equipment, in systems whose capacity matches peak loads, serving a building designed and constructed to the lowest practical loads, will result in the lowest energy use and cost. And finally, Goal 4 addresses the integration of building systems to increase energy savings potential.

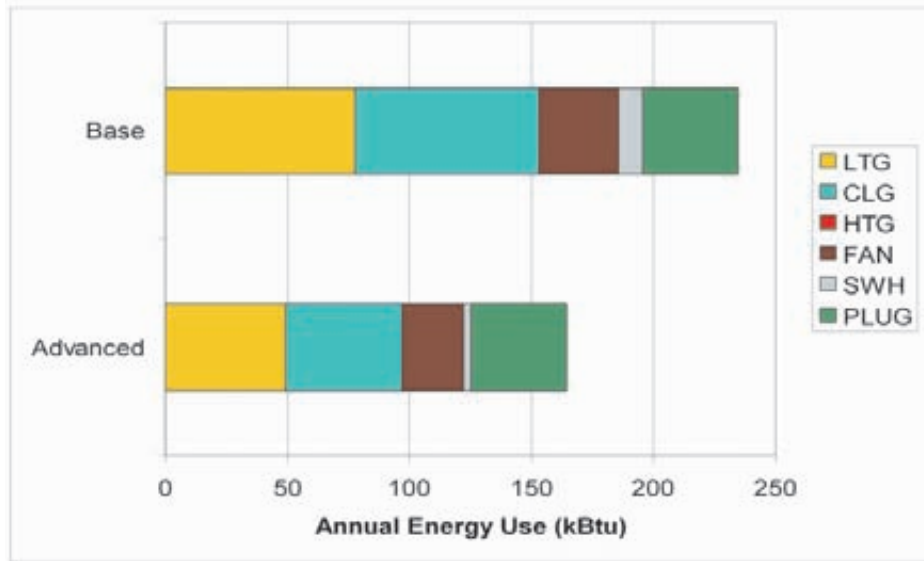

**Figure 2-2.** Estimated annual energy use for lighting, heating, cooling, fans, service water heating, and plug loads for a 5,000 ft<sup>2</sup> small office building in a cooling-dominated climate (Miami). The baseline energy use is for a 90.1-1999 compliant building, and the advanced energy use is for a building compliant with the recommendations of this Guide.

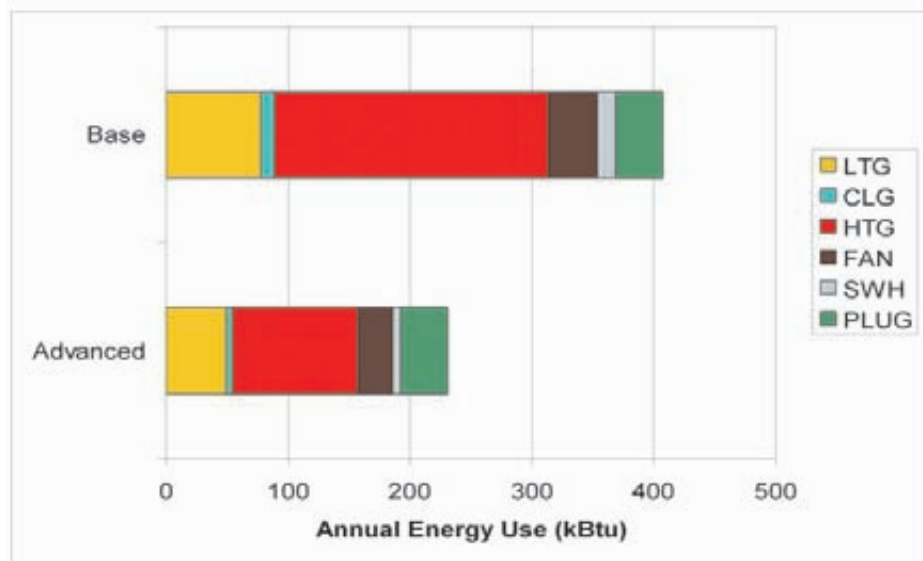

**Figure 2-3.** Estimated annual energy use for lighting, heating, cooling, fans, service water heating, and plug loads for a 5,000 ft<sup>2</sup> small office building in a heating-dominated climate (Duluth). The baseline energy use is for a 90.1-1999 compliant building, and the advanced energy use is for a building compliant with the recommendations of this Guide.

**Energy Goals in Broader Pre-Design Context:**

A typical “integrated” pre-design process includes the following steps in sequence, with energy-related actions flagged (\*).

Activities	Responsibilities	Where to Find Information
1. Select Team a. Design (Architect, Engineer, or Design Build Team) b. QA, Quality Assurance * c. Construction Manager (CM)/General Contractor (GC)/ Estimator	Owner evaluates potential service providers and selects team.	Chapter 4, QA1 and QA2
2. Owner’s Project Requirements (OPR) * a. Document Functional and Spatial Requirements b. Document Energy Efficiency Goals	Owner, Designer analyze the project site, Owner’s needs, and strategic sets presented in this Guide and document them defining the Owner’s Project Requirements (OPR) <sup>1</sup> and goals.	Chapter 4, QA3, Table 2-1 Chapter 3
3. Select Site a. Building Orientation Preference * b. Consider Access to Public Transportation *	Owner, Designer, CM	Table 2-1, Chapter 3, Chapter 4 – EN26 and 29
4. Define Budget (Benchmarks) a. Develop and Review Design Budget b. Develop and Review Construction Budget * c. Develop and Review QA Budget *	Owner, Designer, CM, Estimator Designer, Owner CM, Estimator, Owner QA	Chapter 4, QA4
5. Design and Construction Schedule	Owner, Designer, CM, GC	Chapter 4, QA5
6. Define Specific System Preferences *	Owner, Designer, CM	Chapter 4
7. Define Energy Costs/Efficiency Program Opportunities	Owner, Designer	
8. Codes/Standards Requirements/Targets	Designer, Owner	
9. Establish Prioritized List of Energy Goals *	Owner, Designer, CM or GC	Table 2-1, Chapter 3

1. *Owner’s Project Requirements.* The OPR is a written document that details the functional requirements of a project and the expectations of how the facility will be used and operated. This includes strategies and recommendation selected from this Guide (see Table 2-1 and Chapter 3) that will be incorporated into the project, anticipated hours of operation provided by the owner, and basis of design assumptions made. The OPR forms the foundation of what the team is tasked with accomplishing by defining project and design goals, measurable performance criteria, Owner directives, budget, schedules, and supporting information. Quality assurance process depends on a clear, concise, and comprehensive Owner’s Project Requirements document (see Chapter 4, “Quality Assurance,” QA3, for more information).

## QUALITY ASSURANCE: IN-HOUSE OR THIRD PARTY?

Users of this Guide may debate whether to use outside third parties or in-house staff for the quality assurance (QA) tasks in the design, construction, and acceptance phases of the project. A case can be made for either approach depending on project budget, design complexity, capabilities of the design and construction team, and availability of local commissioning expertise. While both approaches can be effective, building owners should insist that the QA tasks be done by a party who is independent from the design and construction team. Independent review ensures that “fresh eyes” are applied to energy performance QA.

Where the in-house approach is deemed to be in the best interests of the building owner, the QA tasks are best accomplished by personnel with no direct interest in the project. For example, qualified staff working on other projects could be assigned as disinterested parties to check and verify the work of their colleagues. However, building owners can expect to get the most independent QA review from outside third parties. Indeed, most of the literature on building commissioning and energy performance QA recommends or requires independent outside reviews.

In either case, building owners should expect to bear the cost of 8-24 professional staff hours to carry out the recommended QA work scope in chapter 4 depending on project specifics.

**Quality Assurance:** During the design process the design team documents its design assumptions (basis of design) and includes them in the OPR. A party other than the installing contractor, architect, or engineer of record should review the contract document and verify that it incorporates the OPR and the associated strategies contained in this Guide before the start of construction. The owner’s agent, if qualified, can provide the required review. This review along with subsequent inspection, testing, and reporting is referred to as “commissioning.” The reviewer provides the owner and designers with written comments outlining where items do not comply with energy efficiency goals. Comments should be resolved and any changes required completed before start of construction. The owner may choose to use an outside third-party to perform this review.

Once the Design Phase is completed, the party that is independent of the design and construction team fulfills the quality assurance role to ensure that the goals, strategies, and recommendations are actually installed and achieved. *This Guide provides recommendations to ensure that the goals, strategies, and actions selected are properly executed during the later stages of the building life-cycle in chapter 4 under “Quality Assurance.”*

## 2. DESIGN PHASE

In this critical Design Phase, the team develops the energy strategies into building plans, sections, details, and specifications. The sequence of many design decisions, such as building and glazing orientation, as well as other identified strategies in this chapter, have a major impact on energy efficiency. They must, therefore, be made much sooner in the process than is typically done. The following steps, presented in sequence, identify the appropriate time in the process to apply specific recommendations from this Guide.

### Energy in the Context of Design Phase Process

Activities	Responsibilities	Where to Find Information
1. Develop diagrammatic building plans that satisfy functional program requirements	Designer	
2. Incorporate building envelope design strategies to reduce loads on energy-using systems ✱	Designer	Table 2-1, Chapter 3, Chapter 4
3. Develop site plan to make best use of building orientation and daylighting strategies ✱	Designer	Table 2-1, Chapter 3, Chapter 4, EN26 and EN29
4. Select building systems and efficiency level ✱	Designer, Owner, CM	Chapters 3 and 4 Recommendations
5. Develop building plans, sections, and details incorporating above strategies	Designer	
6. Continue to develop architectural and lighting details, including energy implications. For example: lighting, fenestration, and exterior sun control ✱	Designer	Chapters 3 and 4
7. Refine aesthetic details incorporating above details where applicable, for example: building elevations reflect appropriate location and size of windows	Designer	Chapter 4
8. Design review—verify that project meets original goals ✱	Owner, Designer, QA, CM	Chapters 3 and 4
9. Calculate building HVAC loads. Use recommended loads for lighting power density from this Guide ✱	Designer; often equipment manufacturer (EM) is involved	Chapter 3 Chapter 4, “Lighting”
10. Match capacity of HVAC systems to design loads. Use efficiency of equipment as recommended by this Guide ✱	Designer, EM	Chapter 3 Chapter 4, “Lighting”
11. Perform final coordination and integration of architectural, mechanical, and electrical systems ✱	Designer	Chapters 3 and 4
12. Develop specifications for all systems ✱	Designer	
13. Integrate commissioning specifications into project manual ✱	QA	Chapter 4, “Lighting,” Scope
14. Perform final cost estimates	CM, GC, Estimator	
15. Review and provide revisions to final design documents	Owner, Designer, QA	Chapter 3, Chapter 4, QA6



### 3. CONSTRUCTION

The best of design won't yield the expected energy savings if the construction plans and specifications are not correctly executed. This section outlines what the project team can do to keep the construction in line with goals.

#### Energy in the Context of the Bidding and Construction Process

Activities	Responsibilities	Where to Find Information
1. Pre-bid conference—Discuss importance of energy systems to contractors/subcontractors ✱	Owner, Designer, CM	
2. Define quality control/commissioning role during pre-bid and contract meetings	Owner, QA, CM	Chapter4, QA7
3. Regular updates on energy efficiency-related measures at job meetings	Owner, Designer, CM	
4. Verify building envelope construction	QA	Chapter 4, QA8
5. Verify HVAC and electrical systems requirements are met	QA	Chapter 4, QA9
6. Purchase computers and energy-using appliances that meet Energy Star efficiency for low energy use	Owner	Chapter 4, PL3

During construction, the party that is independent of the design and construction team conducts site visits to verify building envelope construction and rough-in of HVAC and electrical systems. The purposes of these visits are as follows:

- **Observations for Operability and Maintainability.** Participate in an ongoing review of the building envelope, mechanical systems, and electrical systems. Prepare field notes and deficiency lists and distribute to the owner, designer, and CM.
- **Verify Access Requirements.** Review shop drawings and perform construction observations to verify that the required access to systems and equipment has been provided.
- **Review Test and Balance (TAB) Plan.** Meet with the construction team to review the TAB required and establish a schedule and plan.
- **Random Spot Verification of Checklists.** Randomly verify prefunctional checklists completed by contractors indicating system is ready for functional testing.

A written report on the site visit that documents issues that require resolution by the design and construction team should be provided. The estimated level of effort is two to four hours during the construction phase for the size of small office buildings covered by this Guide.

### 4. ACCEPTANCE

At this final stage of construction, the project team and the independent party verifies that systems are operating as intended. When the team is satisfied that all systems are performing as intended, the quality assurance effort of the design and construction team is complete. If a third party commissioning provider is involved, estimated level of effort is two to eight hours during the acceptance phase.

Activities	Responsibilities	Where to Find Information
1. Assemble punch list of required items to be completed	GC, CM	
2. Performance testing, as required of general contractor and subcontractors ✱	GC, CM, Subcontractors	Chapter 4, QA10
3. Building is identified as substantially complete	QA, Owner, Designer	Chapter 4, QA11
4. Maintenance manual submitted and accepted	QA, Owner, Designer	Chapter 4, QA12
5. Resolve quality control issues identified throughout the construction phase	QA, Owner, Designer	Chapter 4, QA13
6. Final acceptance	Designer, Owner	Chapter 4, QA14

## 5. OCCUPANCY

During the first year of operation, the building operator reviews the overall operation and performance of the building. Building systems not performing as expected are discussed with the design and construction team and issues are resolved during the warranty period.

Activities	Responsibilities	Where to Find Information
1. Establish building maintenance program	Owner and staff, QA	Chapter 4, QA15
2. Create post-occupancy punch list	Owner and staff	
3. Monitor post-occupancy performance	Owner and staff, QA	Chapter 4, QA16

## 6. OPERATION

Energy use, changes in hours of operation, and additions of energy-consuming equipment are documented and compared against previous data to determine if the building and its systems are operating at peak performance for the life of the building. Reducing the actual energy use of small office buildings will only be achieved if the design and construction activities include advisory energy-tracking information that is conveyed to the end-user of the building as part of the design package. This information should be developed in simple language and format, which will, as a minimum, allow the end-user to track and benchmark the facility's utility bills and take basic action to maintain the intended efficiency of the original design. Additional information on energy effective operation and ongoing energy management is available in the *ASHRAE Handbook—HVAC Applications*.

Table 2-1. Energy Goals and Strategies

Prioritize Goals	General Strategies	Detailed Strategies	Recommendations (See Chapter 3)	How To's (See Chapter 4)
<b>Goal 1. Reduce loads on energy-using systems</b>				
Reduce internal loads	<p><b>Equipment and Appliances:</b> Reduce both cooling loads and energy use</p> <p><b>Lighting:</b> Reduce both cooling loads and energy use</p>	Use more efficient equipment and appliances	Use low-energy computers and monitors; use Energy Star equipment	PL1 to PL3
		Use controls to minimize usage and waste	Turn off or use “sleep mode” on computers, monitors, copiers, and other equipment	
		Educate occupants		EL5, DL1, DL2, DL9
		Maximize the benefits of daylighting	Vertical glazing, skylights, interior lighting	EN26, 29, 32-44 DL1-13
		Use skylights and north-facing clerestories to daylight interior zones	Skylights and vertical glazing	DL7
		Use efficient electric lighting system	Interior lighting	EL1 to EL26
		Use separate controls for lighting in areas near windows	Interior lighting	DL1-2, 9-12 EL5, 7-8
		Use automatic controls to turn off lights when not in use	Interior lighting	DL2 EL5, 7-8
		Use beneficial building form and orientation		EN26, EN29
Reduce heat gain/loss through building envelope	Control solar gain to reduce cooling load through windows	Minimize windows east and west, maximize north and south	Vertical glazing	EN26, EN29
		Use glazing with low solar heat gain coefficient (SHGC)	Vertical glazing, skylights	EN22-24, 27, 31-32
		External shade glazing to reduce solar heat gain and glare	Vertical glazing	EN24

Table 2-1. Energy Goals and Strategies (continued)

Prioritize Goals	General Strategies	Detailed Strategies	Recommendations (See Chapter 3)	How To's (See Chapter 4)
Reduce heat gain/loss through building envelope (continued)	Control solar gain to reduce cooling load through windows	Use vegetation on S/E/W to control solar heat gain (and glare)	Vertical glazing	EN28
	Reduce solar gain through opaque surfaces to reduce cooling load	Increase insulation of opaque surfaces	Roofs, walls, floors, doors	EN2 to EN20
		Increase roof surface reflectance and emittance	Roofs	EN1
		Shade building surfaces		
	Reduce conductive heat gain and loss through building envelope	Increase insulation on roof, walls, floor, slabs, and doors and decrease window U-factor	Roofs, walls, floors, doors, vertical glazing	EN2 to EN20
	Reduce infiltration	Provide continuous air barrier		
	Reduce heat gain or loss from ventilation exhaust air	Use energy recovery to precondition outdoor air	Energy recovery	
	Reduce peak heating and cooling loads	Increase thermal mass		
	Utilize passive solar designs	Use thermal storage, trombe walls, interior mass		EN30
	Reduce heat gain and loss in ductwork	Insulate ductwork		HV10
Refine building to suit local conditions	Consider natural ventilation, highest potential in marine climates, high potential in dry climates	No ductwork outside the building envelope		HV9
		Operable windows with screens so that air conditioning and heating are not necessary during transition periods		EN25
		For buildings with operable windows, design building layout for effective cross-ventilation		EN25

**Table 2-1. Energy Goals and Strategies (continued)**

Prioritize Goals	General Strategies	Detailed Strategies	Recommendations (See Chapter 3)	How To's (See Chapter 4)
<b>Goal 2. Size HVAC systems for reduced loads</b>				
Properly size equipment	Calculate load			HV3
	Size equipment			HV1, 2, 4
<b>Goal 3. Use more efficient systems</b>				
Use more efficient HVAC systems	Select efficient cooling equipment	Meet or exceed listed equipment efficiencies in “Recommendations” chapter	HVAC	HV1, 2, 4, 6, 17
		Meet or exceed listed part load performances in “Recommendations” chapter	HVAC	HV1, 2, 4, 6, 21
	Select efficient heating equipment	Meet or exceed listed equipment efficiencies in “Recommendations” chapter	HVAC	HV1, 2, 6, 16, 20
	Select efficient energy recovery equipment	Meet or exceed listed equipment efficiencies in “Recommendations” chapter		HV5, 17
Improve outdoor air ventilation	Control outdoor air dampers	Use air economizer		HV7, 14
		Use demand-controlled ventilation	Ventilation	HV7, 14, 22
		Shut off outdoor air and exhaust air dampers during unoccupied periods	Ventilation	HV7, 8, 14
Improve fan power	Design efficient duct distribution system	Minimize duct and fitting losses	Ducts	HV9, 18, 19
		Reduce duct leakage	Ducts	HV11
	Select efficient motors	Use high-efficiency motors		HV12

**Table 2-1. Energy Goals and Strategies (continued)**

Prioritize Goals	General Strategies	Detailed Strategies	Recommendations (See Chapter 3)	How To's (See Chapter 4)
Improve HVAC controls	Use control strategies that reduce energy use	Divide building into thermal zones		HV13, 21
		Use time-of-day scheduling, temperature setback and setup, pre-occupancy purge		HV14
Ensure proper air distribution	Test, adjust, and balance the air distribution system	Use industry-accepted procedures		HV15
Use more efficient SWH systems	Select efficient service water heating equipment	Meet or exceed listed equipment efficiencies in “Recommendations” chapter	SWH	WH1-4, 7-8
	Minimize distribution losses	Use point-of-use units		WH1-2, 7-8
		Minimize pipe distribution		WH5
		Insulate piping		WH6
Use more efficient lighting	More efficient interior lighting	Do not use incandescent lighting unless it will be used infrequently		
		Use more efficient electric lighting system	More efficient lamps, ballasts, ceiling fixtures, and task lights	
	More efficient exterior lighting		(See separate table)	
<b>Goal 4. Refine Systems Integration</b>				
Integrate building systems	Integrate systems—High-efficiency Adv. Case			EN23, DL8, DL13, QAI
	Integrate systems—Daylight Adv. Case		Advanced daylighting option	EN23, DL8, DL13, QAI

# Recommendations by Climate

# 3

Users should determine the recommendations for their construction project by first locating the correct climate zone. The U.S. Department of Energy (DOE) has identified eight climate zones for the United States, with each defined by county borders, as shown in Figure 3-1. This Guide uses these DOE climate zones in defining energy recommendations that vary by climate.

This chapter contains a unique set of energy efficient recommendations for each climate zone, along with an example of an existing building which illustrates emerging, energy conserving design ideas. Both the examples and recommendation tables represent a way, but not the only way, for reaching the 30 percent energy-savings target over Standard 90.1–1999. Other approaches may also save energy but they are not part of the scope of this Guide; assurance of those savings is left to the user. The user should note that the recommendation tables do not include all of the components listed in Standard 90.1 since the Guide focuses only on the primary energy systems within a building. When a recommendation is provided, the recommended value differs from the requirements in Standard 90.1–1999. Where “No recommendation” is indicated in the “Recommendation” column of the tables, the user must meet at least the minimum requirements of Standard 90.1 or the requirements of local codes whenever they exceed the requirements of Standard 90.1.

## BONUS SAVINGS

Chapter 4 provides additional recommendations and strategies for savings for plug loads and exterior lighting over and above the 30 percent savings recommendations contained in the following eight climate regions. See page 91 in Chapter 4 for specifics.

Each of the climate zone recommendation tables includes a set of common items arranged by building subsystem: envelope, lighting, HVAC, and service water heating (SWH). Recommendations are included for each item, or subsystem, by component within that subsystem. For some subsystems recommendations depend on the construction type. For example, insulation values are given for mass, metal building, steel framed, and wood framed wall types. For other subsystems recommendations are given for each subsystem attribute. For example, vertical glazing recommendations are given for its size, thermal transmittance, solar heat gain coefficient, window orientation, and exterior sun control.

The final column in each table lists references to how-to tips for implementing the recommended criteria. The tips are found in chapter 4 under separate sections coded for envelope (EN), daylighting (DL), electric lighting (EL), HVAC systems and equipment (HV), and water heating systems and equipment (WH) suggestions. Besides how-to design and maintenance suggestions that represent good practice, these tips include cautions for what to avoid. Important quality assurance considerations and recommendations are also given for the building design, construction, and post occupancy phases. Note that each tip is tied to the applicable climate zones by a color-coded dot in chapter 4.



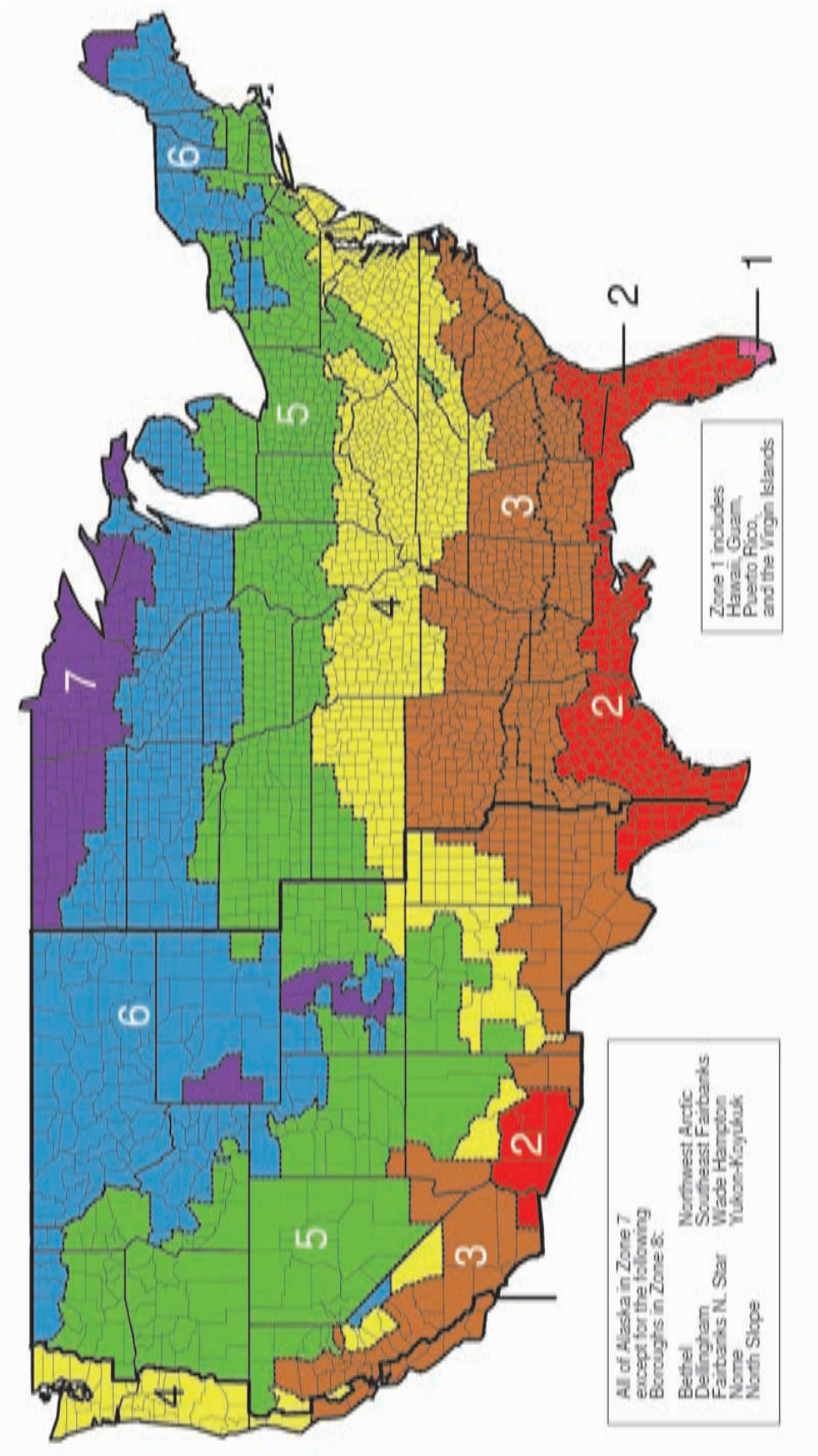

**Figure 3-1.** U.S. Department of Energy climate zone map. A list of counties and their respective climate zones can be found on the following pages and at the following web site: [www.energycodes.gov](http://www.energycodes.gov).



# Zone 1

## Florida

Broward  
Miami-Dade  
Monroe

## Guam

## Hawaii

## Puerto Rico

## US Virgin Islands

Climate Zone 1 Recommendation Table

	Item	Component	Recommendation	How-To's in Chapter 4
Envelope	Roof	Insulation entirely above deck	R-15 c.i.	EN1-2, 17, 20-21
		Metal building	R-19	EN1, 3, 17, 20-21
		Attic and other	R-30	EN4, 17-18, 20-21
		Single rafter	R-30	EN5, 17, 20-21
		Surface reflectance/emittance	0.65 initial/0.86	EN1
	Walls	Mass (HC > 7 Btu/ft <sup>2</sup> )	No recommendation	EN6, 17, 20-21
		Metal building	R-13	EN7, 17, 20-21
		Steel framed	R-13	EN8, 17, 20-21
		Wood framed and other	R-13	EN9, 17, 20-21
		Below-grade walls	No recommendation	EN10, 17, 20-21
	Floors	Mass	R-4.2 c.i.	EN11, 17, 20-21
		Steel framed	R-19	EN12, 17, 20-21
		Wood framed and other	R-19	EN12, 17, 20-21
	Slabs	Unheated	No recommendation	EN17, 19-21
		Heated	No recommendation	EN17, 19-21
	Doors	Swinging	U-0.70	EN15, 20-21
		Non-swinging	U-1.45	EN16, 20-21
Vertical Glazing	Window to wall ratio (WWR)	20% to 40% maximum	EN23, 36-37	
	Thermal transmittance	U-0.56	EN25	
	Solar heat gain coefficient (SHGC)	N, S, E, W - N only - 0.49 0.35	EN27-28	
	Window orientation	$(A_N * SHGC_N + A_S * SHGC_S) > (A_E * SHGC_E + A_W * SHGC_W)$	A <sub>x</sub> —Window area for orientation x EN26-32	
Skylights	Exterior sun control (S, E, W only)	Projection factor 0.5	EN24, 28, 30, 36, 40, 42 DL5-6	
	Maximum percent of roof area	3%	DL5-7, DL8, DL13	
	Thermal transmittance	U-1.36	DL7, DL8, DL13	
	Solar heat gain coefficient (SHGC)	0.19	DL8, DL13	
Lighting	Interior Lighting	Lighting power density (LPD)	0.9 W/ft <sup>2</sup>	EL1-2, 4, 8, 10-16
		Light source (linear fluorescent)	90 mean lumens/watt	EL4, 9, 17
		Ballast	Electronic ballast	EL4
		Dimming controls for daylight	Dim fixtures within 12 ft of N/S window wall or within 8 ft of skylight edge	DL1, 9-11, EL6-7
		Harvesting for WWR 25% or higher		
		Occupancy controls	Auto-off all unoccupied rooms	DL2, EL5, 6
		Interior room surface reflectances	80%+ on ceilings, 70%+ on walls and vertical partitions	DL3-4, EL3
HVAC	HVAC	Air conditioner (0-65 KBtuh)	13.0 SEER	HV1-2, 4, 6, 12, 16-17, 20
		Air conditioner (>65-135 KBtuh)	11.3 EER/11.5 IPLV	HV1-2, 4, 6, 12, 16-17, 20
		Air conditioner (>135-240 KBtuh)	11.0 EER/11.5 IPLV	HV1-2, 4, 6, 12, 16-17, 20
		Air conditioner (>240 KBtuh)	10.6 EER/11.2 IPLV	HV1-2, 4, 6, 12, 16-17, 20
		Gas furnace (0-225 KBtuh - SP)	80% AFUE or E <sub>t</sub>	HV1-2, 6, 16, 20
		Gas furnace (0-225 KBtuh - Split)	80% AFUE or E <sub>t</sub>	HV1-2, 6, 16, 20
		Gas furnace (>225 KBtuh)	80% E <sub>c</sub>	HV1-2, 6, 16, 20
		Heat pump (0-65 KBtuh)	13.0 SEER/7.7 HSPF	HV1-2, 4, 6, 12, 16-17, 20
		Heat pump (>65-135 KBtuh)	10.6 EER/11.0 IPLV/3.2 COP	HV1-2, 4, 6, 12, 16-17, 20
	Heat pump (>135 KBtuh)	10.1 EER/11.5 IPLV/3.1 COP	HV1-2, 4, 6, 12, 16-17, 20	
	Economizer	Air conditioners & heat pumps- SP	No recommendation	HV23
	Ventilation	Outdoor air damper	Motorized control	HV7-8
		Demand control	CO <sub>2</sub> sensors	HV7, 22
	Ducts	Friction rate	0.08 in. w.c./100 feet	HV9, 18
Sealing		Seal class B	HV11	
Location		Interior only	HV9	
Insulation level		R-6	HV10	
SWH	Service Water Heater	Gas storage	90% E <sub>t</sub>	WH1-4
		Gas instantaneous	0.81 EF or 81% E <sub>t</sub>	WH1-4
		Electric storage 12 kW	EF > 0.99 – 0.0012xVolume	WH1-4
		Pipe insulation (d<1½ in./ d≥1½ in.)	1 in./ 1½ in.	WH6

**Note:** If the table contains “No recommendation” for a component, the user must meet the more stringent of either Standard 90.1 or the local code requirements in order to reach the 30% savings target.



Photographs courtesy of Michael Carlson

**Figure 3-2.** Sarasota County’s Twin Lakes Project demonstrates a sustainable approach to site development, efficient use of water and energy, and conservation of materials.

## Zone 1—Twin Lakes Park Office Complex

SARASOTA, FLA.

The Twin Lakes Park office complex is the first opportunity for the Sarasota County government to carry out its vision of creating a sustainable environment. Designed by Cardinal, Carlson + Partners, the project involved renovating an existing 17,000-square-foot office building and creating an additional free-standing building of about 8,300 square feet. The result is a workplace that is appealing inside and out for its architecture and resource-conserving strategies.

To reduce heat gain from Florida’s harsh sun, there are no windows on the east and west sides of the office building. Windows on the south side of the building are shaded by a roof overhang. The extensive use of insulated, double-pane, impact-resistant windows on the north side brings in natural light.

---

This example building demonstrates good design and construction practices suitable for this particular climate zone. In some cases, the example building may have incorporated additional features that go beyond the scope of the recommendations of this Guide.



**Figure 3-3.** A sensor measures the amount of natural light coming in and adjusts overhead fluorescent lights accordingly.



**Figure 3-4.** Nontoxic paints, floorings, composite woods, adhesives, sealants, and other materials were chosen to promote a healthier indoor air quality.



**Figure 3-5.** Insulated, double-pane, impact-resistant windows bring in natural light.

The project uses daylighting combined with daylight sensors that automatically adjust when artificial lighting is not needed. Fluorescent lights supplement the natural lighting and gradually brighten when clouds block the sun.

While moisture can create problems for buildings in Zone 1, which can sometimes receive an average of 54 inches of rainfall in a year, gutters and downspouts channel the rain from the roof into a 28,000-gallon underground cistern. Filters remove debris from the stored rainwater. The collected water is used to flush the low-flow toilets and irrigate the drought-tolerant landscaping.

Instead of traditionally dumping the heat to the outside air, a more efficient geothermal air-conditioning system is used that pumps cool groundwater through a heat exchanger to cool the building. The project also features a small-scale photovoltaic system that converts sunlight striking the roof into electricity. Nontoxic paints, floorings, composite woods, adhesives, sealants, and other materials were chosen to promote a healthier indoor air quality.

The buildings' exterior walls, made from precast panels of lightweight autoclaved aerated concrete, are full of air pockets that provide better insulation. The buildings' insulated rating is more than double what is used in standard construction.



# Zone 2

## Alabama

Baldwin  
Mobile

## Arizona

La Paz  
Maricopa  
Pima  
Pinal  
Yuma

## California

Imperial

## Florida

Alachua  
Baker  
Bay  
Bradford  
Brevard  
Calhoun  
Charlotte  
Citrus  
Clay  
Collier  
Columbia  
DeSoto  
Dixie  
Duval  
Escambia  
Flagler  
Franklin  
Gadsden  
Gilchrist  
Glades  
Gulf  
Hamilton  
Hardee  
Hendry  
Hernando  
Highlands  
Hillsborough  
Holmes  
Indian River  
Jackson  
Jefferson  
Lafayette  
Lake  
Lee  
Leon

Levy  
Liberty  
Madison  
Manatee  
Marion  
Martin  
Nassau  
Okaloosa  
Okeechobee  
Orange  
Osceola  
Palm Beach  
Pasco  
Pinellas  
Polk  
Putnam  
Santa Rosa  
Sarasota  
Seminole  
St. Johns  
St. Lucie  
Sumter  
Suwannee  
Taylor  
Union  
Volusia  
Wakulla  
Walton  
Washington

## Georgia

Appling  
Atkinson  
Bacon  
Baker  
Berrien  
Brantley  
Brooks  
Bryan  
Camden  
Charlton  
Chatham  
Clinch  
Colquitt  
Cook  
Decatur  
Echols  
Effingham  
Evans  
Glynn  
Grady  
Jeff Davis

Lanier  
Liberty  
Long  
Lowndes  
McIntosh  
Miller  
Mitchell  
Pierce  
Seminole  
Tattnall  
Thomas  
Toombs  
Ware  
Wayne

## Louisiana

Acadia  
Allen  
Ascension  
Assumption  
Avoyelles  
Beauregard  
Calcasieu  
Cameron  
East Baton Rouge  
East Feliciana  
Evangeline  
Iberia  
Iberville  
Jefferson  
Jefferson Davis  
Lafayette  
Lafourche  
Livingston  
Orleans  
Plaquemines  
Pointe Coupee  
Rapides  
St. Bernard  
St. Charles  
St. Helena  
St. James  
St. John the Baptist  
St. Landry  
St. Martin  
St. Mary  
St. Tammany  
Tangipahoa  
Terrebonne  
Vermilion  
Washington  
West Baton Rouge

West Feliciana

## Mississippi

Hancock  
Harrison  
Jackson  
Pearl River  
Stone

## Texas

Anderson  
Angelina  
Aransas  
Atascosa  
Austin  
Bandera  
Bastrop  
Bee  
Bell  
Bexar  
Bosque  
Brazoria  
Brazos  
Brooks  
Burleson  
Caldwell  
Calhoun  
Cameron  
Chambers  
Cherokee  
Colorado  
Comal  
Coryell  
DeWitt  
Dimmit  
Duval  
Edwards  
Falls  
Fayette  
Fort Bend  
Freestone  
Frio  
Galveston  
Goliad  
Gonzales  
Grimes  
Guadalupe  
Hardin  
Harris  
Hays  
Hidalgo  
Hill

Houston  
Jackson  
Jasper  
Jefferson  
Jim Hogg  
Jim Wells  
Karnes  
Kenedy  
Kinney  
Kleberg  
La Salle  
Lavaca  
Lee  
Leon  
Liberty  
Limestone  
Live Oak  
Madison  
Matagorda  
Maverick  
McLennan  
McMullen  
Medina  
Milam  
Montgomery  
Newton  
Nueces  
Orange  
Polk  
Real  
Refugio  
Robertson  
San Jacinto  
San Patricio  
Starr  
Travis  
Trinity  
Tyler  
Uvalde  
Val Verde  
Victoria  
Walker  
Waller  
Washington  
Webb  
Wharton  
Willacy  
Williamson  
Wilson  
Zapata  
Zavala

Climate Zone 2 Recommendation Table

	Item	Component	Recommendation	How-To's in Chapter 4
Envelope	Roof	Insulation entirely above deck	R-15 c.i.	EN1-2, 17, 20-21
		Metal building	R-19	EN1, 3, 17, 20-21
		Attic and other	R-38	EN4, 17-18, 20-21
		Single rafter	R-38	EN5, 17, 20-21
		Surface reflectance/emittance	0.65 initial/0.86	EN1
	Walls	Mass (HC > 7 Btu/ft <sup>2</sup> )	R-7.6 c.i.	EN6, 17, 20-21
		Metal building	R-13	EN7, 17, 20-21
		Steel framed	R-13	EN8, 17, 20-21
		Wood framed and other	R-13	EN9, 17, 20-21
		Below-grade walls	No recommendation	EN10, 17, 20-21
	Floors	Mass	R-6.3 c.i.	EN11, 17, 20-21
		Steel framed	R-19	EN12, 17, 20-21
		Wood framed and other	R-19	EN12, 17, 20-21
	Slabs	Unheated	No recommendation	EN17, 19-21
		Heated	No recommendation	EN17, 19-21
	Doors	Swinging	U-0.70	EN15, 20-21
		Non-swinging	U-1.45	EN16, 20-21
	Vertical Glazing	Window to wall ratio (WWR)	20% to 40% max	EN23, 36-37
Thermal transmittance		U-0.45	EN25	
Solar heat gain coefficient (SHGC)		N, S, E, W - 0.31 N only - 0.44	EN27-28	
Window orientation		$(A_N * SHGC_N + A_S * SHGC_S) > (A_E * SHGC_E + A_W * SHGC_W)$	A <sub>x</sub> —Window area for orientation x EN26-32	
Exterior sun control (S, E, W only)		Projection Factor 0.5	EN24, 28, 30, 36, 40, 42 DL5-6	
Skylights	Maximum percent of roof area	3%	DL5-7, DL8, DL13	
	Thermal transmittance	U-1.36	DL7, DL8, DL13	
	Solar heat gain coefficient (SHGC)	0.19	DL8, DL13	
Lighting	Interior Lighting	Lighting power density (LPD)	0.9 W/ft <sup>2</sup>	EL1-2, 4, 8, 10-16
		Light source (linear fluorescent)	90 mean lumens/watt	EL4, 9, 17
		Ballast	Electronic ballast	EL4
		Dimming controls for daylight Harvesting for WWR 25% or higher	Dim fixtures within 12 ft of N/S window wall or within 8 ft of skylight edge	DL1, 9-11, EL6-7
		Occupancy controls	Auto-off all unoccupied rooms	DL2, EL5, 6
		Interior room surface reflectances	80%+ on ceilings, 70%+ on walls and vertical partitions	DL3-4, EL3
HVAC	HVAC	Air conditioner (0-65 KBtuh)	13.0 SEER	HV1- 2, 4, 6, 12, 16-17, 20
		Air conditioner (>65-135 KBtuh)	11.3 EER/11.5 IPLV	HV1- 2, 4, 6, 12, 16-17, 20
		Air conditioner (>135-240 KBtuh)	11.0 EER/11.5 IPLV	HV1- 2, 4, 6, 12, 16-17, 20
		Air conditioner (>240 KBtuh)	10.6 EER/11.2 IPLV	HV1- 2, 4, 6, 12, 16-17, 20
		Gas furnace (0-225 KBtuh - SP)	80% AFUE or E <sub>t</sub>	HV1- 2, 6, 16, 20
		Gas furnace (0-225 KBtuh - Split)	80% AFUE or E <sub>t</sub>	HV1- 2, 6, 16, 20
		Gas furnace (>225 KBtuh)	80% E <sub>c</sub>	HV1- 2, 6, 16, 20
		Heat pump (0-65 KBtuh)	13.0 SEER/7.7 HSPF	HV1- 2, 4, 6, 12, 16-17, 20
		Heat pump (>65-135 KBtuh)	10.6 EER/11.0 IPLV/3.2 COP	HV1- 2, 4, 6, 12, 16-17, 20
	Heat pump (>135 KBtuh)	10.1 EER/11.5 IPLV/3.1 COP	HV1- 2, 4, 6, 12, 16-17, 20	
	Economizer	Air conditioners & heat pumps- SP	No recommendation	HV23
	Ventilation	Outdoor air damper	Motorized control	HV7-8
		Demand control	CO <sub>2</sub> Sensors	HV7, 22
Ducts	Friction rate	0.08 in. w.c./100 feet	HV9, 18	
	Sealing	Seal class B	HV11	
	Location	Interior only	HV9	
	Insulation level	R-6	HV10	
SWH	Service Water Heating	Gas storage	90% E <sub>t</sub>	WH1-4
		Gas instantaneous	0.81 EF or 81% E <sub>t</sub>	WH1-4
		Electric storage 12 kW	EF > 0.99 – 0.0012xVolume	WH1-4
		Pipe insulation (d<1½ in./ d≥1½ in.)	1 in./ 1½ in.	WH6

Note: If the table contains “No recommendation” for a component, the user must meet the more stringent of either Standard 90.1 or the local code requirements in order to reach the 30% savings target.



Photographs courtesy of Aker/Zvonkovic Photography

**Figure 3-6.** SpawGlass Construction Corporate Headquarters is calculated to be 56 percent more efficient than the baseline standard due to building orientation, window protection, a light-colored roof, and electrical and HVAC choices.

## Zone 2—SpawGlass Construction Corporate Headquarters

HOUSTON, TEX.

Located in Zone 2 with its extreme summer temperatures, SpawGlass Construction Corporate Headquarters houses the operations of one of Houston’s most successful contracting firms. The building is also the first LEED-certified building in Houston.

This single-story, concrete tilt wall, 20,000-square-foot building is located on a generous four-acre site. Designed by Kirksey, the building features a lobby/conferencing area, enclosed private offices, and open plan support space.

Some of the major features of the building include generous use of natural light, on-site stormwater retention and filtration, water efficiency, and native landscaping. Windows are located throughout the building to provide daylight and views for more than 75

---

This example building demonstrates good design and construction practices suitable for this particular climate zone. In some cases, the example building may have incorporated additional features that go beyond the scope of the recommendations of this Guide.





**Figure 3-7.** (Above) Windows are located throughout the building to provide natural light and views for more than 75 percent of all occupied spaces.



**Figure 3-8.** Water-saving fixtures include low-flow kitchen faucets.



**Figure 3-9.** Native plants, a low planting density, and a weather-monitoring device were installed to help reduce demand for landscape irrigation.

percent of all the occupied spaces. An Energy Star compliant roof system and paving surfaces with a high reflectance help minimize heat absorbed on the site. Water-saving fixtures include motion sensor lavatory faucets, waterless urinals, and low-flow kitchen faucets and shower heads. In addition, vegetated swales and bioretention basins were designed to reduce the rate of stormwater runoff and remove water contaminants.

Some of the energy-saving strategies include the use of occupancy sensor lighting, harmonic transformers, low-E insulated glazing, an east-west orientation, appropriate glazing locations, and an efficient HVAC system.

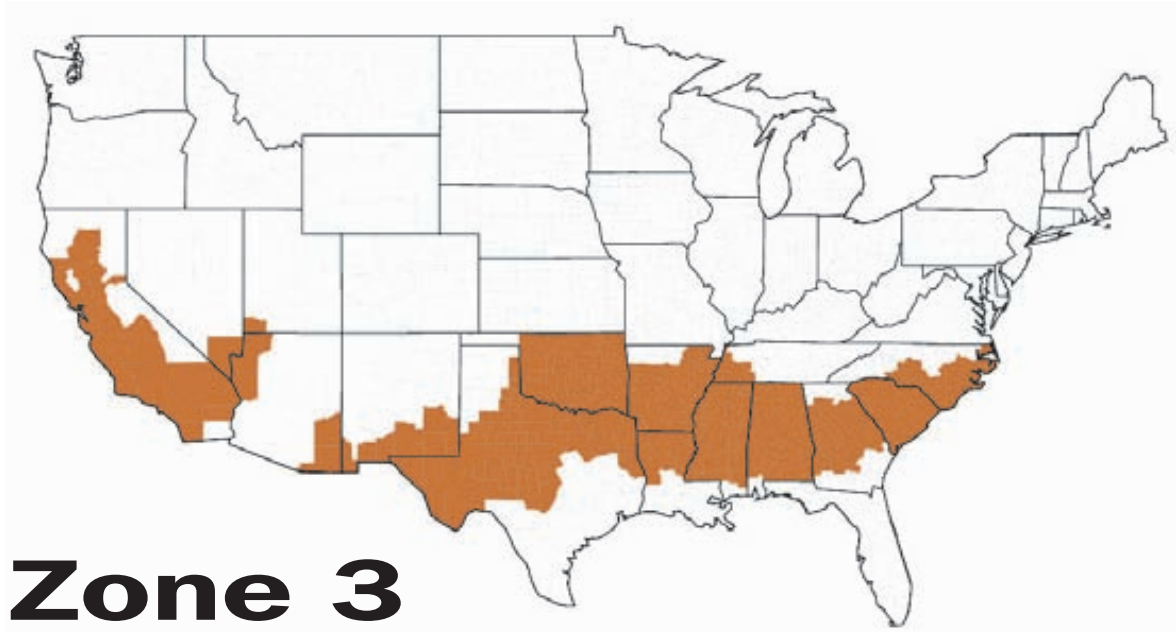

# Zone 3

## Alabama

All counties  
except:  
Baldwin  
Mobile

## Arizona

Cochise  
Graham  
Greenlee  
Mohave  
Santa Cruz

## Arkansas

All counties  
except:  
Baxter  
Benton  
Boone  
Carroll  
Fulton  
Izard  
Madison  
Marion  
Newton  
Searcy  
Stone  
Washington

## California

All counties  
except:  
Alpine  
Amador  
Calaveras  
Del Norte  
El Dorado  
Humboldt  
Imperial  
Inyo  
Lake  
Lassen  
Mariposa  
Modoc  
Mono  
Nevada  
Plumas  
Sierra  
Siskiyou  
Trinity  
Tuolumne

## Georgia

All counties  
except:  
Appling  
Atkinson  
Bacon  
Baker  
Banks  
Berrien  
Brantley  
Brooks  
Bryan  
Catoosa  
Camden  
Charlton  
Chatham  
Chattooga  
Clich  
Colquitt  
Cook  
Dade  
Dawson  
Decatur  
Echols  
Effingham  
Evans  
Fannin  
Floyd  
Franklin  
Gilmer  
Glynn  
Gordon  
Grady  
Habersham  
Hall  
Jeff Davis  
Lanier  
Liberty  
Long  
Lowndes  
Lumpkin  
McIntosh  
Miller  
Mitchell  
Murray  
Pickens  
Pierce  
Rabun  
Seminole  
Stephens  
Tattall  
Thomas  
Toombs  
Towns

## Louisiana

Union  
Walker  
Ware  
Wayne  
White  
Whitfield

Bienville  
Bossier  
Caddo  
Caldwell  
Catahoula  
Claiborne  
Concordia  
De Soto  
East Carroll  
Franklin  
Grant  
Jackson  
La Salle  
Lincoln  
Madison  
Morehouse  
Natchitoches  
Ouachita  
Red River  
Richland  
Sabine  
Tensas  
Union  
Vernon  
Webster  
West Carroll  
Winn

All counties  
except:  
Hancock  
Harrison  
Jackson  
Pearl River  
Stone

Chaves  
Dona Ana  
Eddy  
Hidalgo  
Lea  
Luna  
Otero

## Mississippi

## New Mexico

## Nevada

Clark

## Texas

Andrews  
Archer  
Baylor  
Blanco  
Borden  
Bowie  
Brown  
Burnet  
Callahan  
Camp  
Cass  
Childress  
Clay  
Coke  
Coleman  
Collingsworth  
Collin  
Comanche  
Concho  
Cottle  
Cooke  
Crane  
Crockett  
Crosby  
Culberson  
Dallas  
Dallam  
Dawson  
Delta  
Denton  
Dickens  
Eastland  
Ector  
El Paso  
Ellis  
Erath  
Fannin  
Fisher  
Foard  
Franklin  
Gaines  
Garza  
Gillespie  
Glasscock  
Grayson  
Gregg  
Hall  
Hamilton  
Hardeman

Harrison  
Haskell  
Hemphill  
Henderson  
Hood  
Hopkins  
Howard  
Hudspeth  
Hunt  
Irion  
Jack  
Jeff Davis  
Johnson  
Jones  
Kaufman  
Kendall  
Kent  
Kerr  
Kimble  
King  
Knox  
Lamar  
Lampasas  
Llano  
Loving  
Lubbock  
Lynn  
Marion  
Martin  
Mason  
McCulloch  
Menard  
Midland  
Mills  
Mitchell  
Montague  
Morris  
Motley  
Nacogdoches  
Navarro  
Nolan  
Palo Pinto  
Panola  
Parker  
Pecos  
Presidio  
Rains  
Reagan  
Reeves  
Red River  
Rockwall  
Runnels  
Rusk  
Sabine  
San Augustine

San Saba  
Schleicher  
Scurry  
Shackelford  
Shelby  
Smith  
Somervell  
Stephens  
Sterling  
Stonewall  
Sutton  
Tarrant  
Taylor  
Terrell  
Terry  
Throckmorton  
Titus  
Tom Green  
Upshur  
Upton  
Van Zandt  
Ward  
Wheeler  
Wichita  
Wilbarger  
Winkler  
Wise  
Wood  
Young

## Utah

Washington

## North Carolina

Anson  
Beaufort  
Bladen  
Brunswick  
Cabarrus  
Camden  
Carteret  
Chowan  
Columbus  
Craven  
Cumberland  
Currituck  
Dare  
Davidson  
Duplin  
Edgecombe  
Gaston  
Greene  
Hoke  
Hyde

Johnston  
Jones  
Lenoir  
Martin  
Mecklenburg  
Montgomery  
Moore  
New Hanover  
Onslow  
Pamlico  
Pasquotank  
Pender  
Perquimans  
Pitt  
Randolph  
Richmond  
Robeson  
Rowan  
Sampson  
Scotland  
Stanly  
Tyrrell  
Union  
Washington  
Wayne  
Wilson

## Oklahoma

All counties  
except:  
Beaver  
Cimarron  
Texas

## South Carolina

All counties

## Tennessee

Chester  
Crockett  
Dyer  
Fayette  
Hardeman  
Hardin  
Haywood  
Henderson  
Lake  
Lauderdale  
Madison  
McNairy  
Shelby  
Tipton

Climate Zone 3 Recommendation Table

	Item	Component	Recommendation	How-To's in Chapter 4
Envelope	Roof	Insulation entirely above deck	R-20 c.i.	EN1-2, 17, 20-21
		Metal building	R-13 + R-13	EN1, 3, 17, 20-21
		Attic and other	R-38	EN4, 17-18, 20-21
		Single rafter	R-38	EN5, 17, 20-21
		Surface reflectance/emittance	0.65 initial/0.86	EN1
	Walls	Mass (HC > 7 Btu/ft <sup>2</sup> )	R-9.5 c.i.	EN6, 17, 20-21
		Metal building	R-13	EN7, 17, 20-21
		Steel framed	R-13 + R-3.8 c.i.	EN8, 17, 20-21
		Wood Framed and other	R-13	EN9, 17, 20-21
		Below-grade walls	No recommendation	EN10, 17, 20-21
	Floors	Mass	R-8.3 c.i.	EN11, 17, 20-21
		Steel framed	R-19	EN12, 17, 20-21
		Wood framed and other	R-30	EN12, 17, 20-21
	Slabs	Unheated	No recommendation	EN17, 19-21
		Heated	No recommendation	EN17, 19-21
	Doors	Swinging	U-0.70	EN15, 20-21
		Non-swinging	U-1.45	EN16, 20-21
	Vertical Glazing	Window to wall ratio (WWR)	20% to 40% maximum	EN23, 36-37
		Thermal transmittance	U-0.45	EN25
		Solar heat gain coefficient (SHGC)	N, S, E, W - 0.31    N only - 0.46	EN27-28
Window orientation		$(A_N * SHGC_N + A_S * SHGC_S) > (A_E * SHGC_E + A_W * SHGC_W)$	A <sub>x</sub> —Window area for orientation x EN26-32	
Skylights	Exterior sun control (S, E, W only)	Projection factor 0.5	EN24, 28, 30, 36, 40, 42 DL5-6	
	Maximum percent of roof area	3%	DL5-7, DL8, DL13	
	Thermal transmittance	U-0.69	DL7, DL8, DL13	
Lighting	Interior Lighting	Solar heat gain coefficient (SHGC)	0.19	DL8, DL13
		Lighting power density (LPD)	0.9 W/ft <sup>2</sup>	EL1-2, 4, 8, 10-16
		Light source (linear fluorescent)	90 mean lumens/watt	EL4, 9, 17
		Ballast	Electronic ballast	EL4
		Dimming controls for daylight harvesting for WWR 25% or higher	Dim fixtures within 12 ft of N/S window wall or within 8 ft of skylight edge	DL1, 9-11, EL6-7
		Occupancy controls	Auto-off all unoccupied rooms	DL2, EL5, 6
		Interior room surface reflectances	80%+ on ceilings, 70%+ on walls and vertical partitions	DL3-4, EL3
HVAC	HVAC	Air conditioner (0-65 KBtuh)	13.0 SEER	HV1- 2, 4, 6, 12, 16-17, 20
		Air conditioner (>65-135 KBtuh)	11.0 EER/11.4 IPLV	HV1- 2, 4, 6, 12, 16-17, 20
		Air conditioner (>135-240 KBtuh)	10.8 EER/11.2 IPLV	HV1- 2, 4, 6, 12, 16-17, 20
		Air conditioner (>240 KBtuh)	10.0 EER/10.4 IPLV	HV1- 2, 4, 6, 12, 16-17, 20
		Gas furnace (0-225 KBtuh - SP)	80% AFUE or E <sub>t</sub>	HV1- 2, 6, 16, 20
		Gas furnace (0-225 KBtuh - Split)	80% AFUE or E <sub>t</sub>	HV1- 2, 6, 16, 20
		Gas furnace (>225 KBtuh)	80% E <sub>c</sub>	HV1- 2, 6, 16, 20
		Heat pump (0-65 KBtuh)	13.0 SEER/7.7 HSPF	HV1- 2, 4, 6, 12, 16-17, 20
		Heat pump (>65-135 KBtuh)	10.6 EER/11.0 IPLV/3.2 COP	HV1- 2, 4, 6, 12, 16-17, 20
	Heat pump (>135 KBtuh)	10.1 EER/11.0 IPLV/3.1 COP	HV1- 2, 4, 6, 12, 16-17, 20	
	Economizer	Air conditioners & heat pumps- SP	Cooling capacity > 54 KBtuh	HV23
	Ventilation	Outdoor air damper	Motorized control	HV7-8
		Demand control	CO <sub>2</sub> sensors	HV7, 22
Ducts	Friction rate	0.08 in. w.c./100 feet	HV9, 18	
	Sealing	Seal class B	HV11	
	Location	Interior only	HV9	
	Insulation level	R-6	HV10	
SWH	Service Water Heating	Gas storage	90% E <sub>t</sub>	WH1-4
		Gas instantaneous	0.81 EF or 81% E <sub>t</sub>	WH1-4
		Electric storage 12 kW	EF > 0.99 – 0.0012xVolume	WH1-4
		Pipe insulation (d<1½ in./ d≥1½ in.)	1 in./ 1½ in.	WH6

**Note:** If the table contains “No recommendation” for a component, the user must meet the more stringent of either Standard 90.1 or the local code requirements in order to reach the 30% savings target.



Photographs courtesy of Richard Barnes

**Figure 3-10.** The Thoreau Center for Sustainability is the first public/private partnership project completed in the new Presidio National Park.

## Zone 3—Thoreau Center for Sustainability

SAN FRANCISCO, CALIF.

Located in the rehabilitated historic wards of the Letterman General Hospital, the Thoreau Center for Sustainability is the first construction project in the transformation of San Francisco's Presidio from an army base to a national park and office park. The complex, consisting of four two-story buildings, is the new home to several nonprofit organizations that focus on environmental sustainable development issues.

The Thoreau Center, which was designed by Leddy Maytum Stacy Architects, illustrates how a historic rehabilitation can successfully incorporate energy-conserving strategies. With its proximity to the Pacific Ocean, the site has a very temperate climate that rarely exceeds 80°F. Thus, the buildings feature operable windows and natural ven-

---

This example building demonstrates good design and construction practices suitable for this particular climate zone. In some cases, the example building may have incorporated additional features that go beyond the scope of the recommendations of this Guide.



**Figure 3-11.** An open floor plan and skylights allow natural light to penetrate the buildings.



**Figure 3-12.** The Thoreau Center is a celebration of both historic and new elements.

tilation. The buildings' geometry further encourages natural ventilation because of the shallow floor plates that place occupants close to a window.

To avoid a harsh glare, fluorescent uplighting was selected because of its soft, shadow-free low-glare quality of light, particularly good where there is high computer use. Skylights provide natural lighting. To increase interior daylighting, evergreen trees were removed (and replaced with deciduous trees) on the buildings' south side. Primarily unoccupied spaces are away from daylight sources. Lighting controls are ordinary light switches combined with occupancy sensors in many areas, especially areas with intermittent use.

Low-flow plumbing fixtures were installed because they conserve water as well as reduce distribution pumping energy and lower domestic hot water heating energy. Other water-conserving strategies include the use of drought-tolerant plants in the landscaping, use of low-flow irrigation systems, and the capture of rainwater for supplemental irrigation. Excavation and use of historic drainage structures minimize runoff.

In addition, notable "green" products used throughout the buildings include hydronic panel radiators, natural linoleum flooring, cotton insulation, and cellulose insulation.

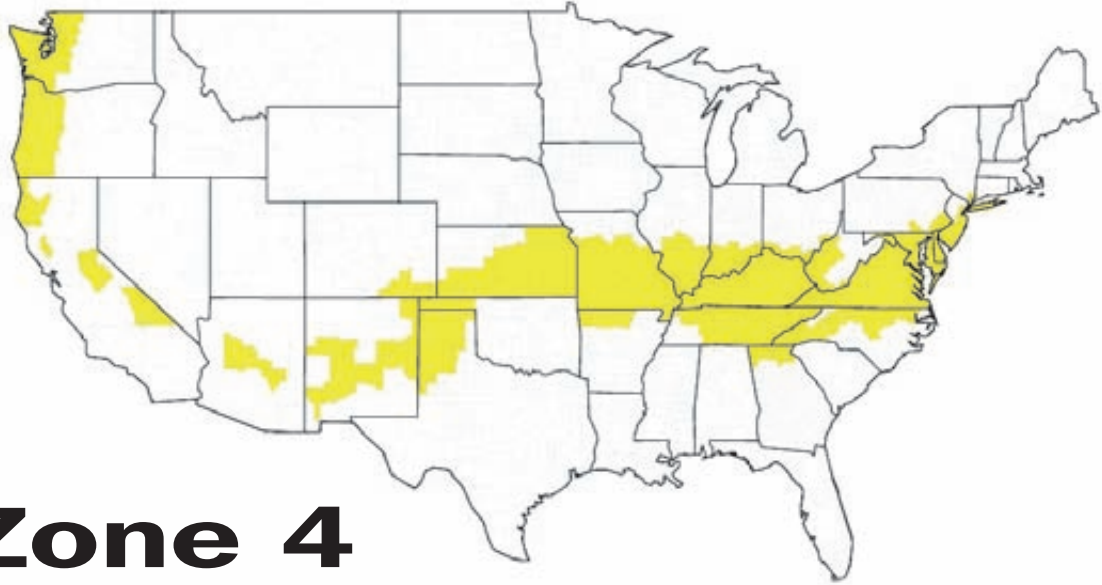

# Zone 4

## Arizona

Gila  
Yavapai

## Arkansas

Baxter  
Benton  
Boone  
Carroll  
Fulton  
Izard  
Madison  
Marion  
Newton  
Searcy  
Stone  
Washington

## California

Amador  
Calaveras  
Del Norte  
El Dorado  
Inyo  
Lake  
Mariposa  
Trinity  
Tuolumne

## Colorado

Baca  
Las Animas  
Otero

## Delaware

All counties

## District of Columbia

## Georgia

Banks  
Catoosa  
Chattooga  
Dade  
Dawson  
Fannin  
Floyd  
Franklin  
Gilmer  
Gordon  
Habersham  
Hall  
Lumpkin  
Murray  
Pickens  
Rabun  
Stephens  
Towns  
Union  
Walker  
White  
Whitfield

## Illinois

Alexander  
Bond  
Brown  
Christian  
Clay  
Clinton  
Crawford  
Edwards  
Effingham  
Fayette  
Franklin  
Gallatin  
Hamilton  
Hardin  
Jackson  
Jasper  
Jefferson  
Johnson  
Lawrence  
Macoupin  
Madison  
Marion  
Massac  
Monroe  
Montgomery  
Perry  
Pope  
Pulaski  
Randolph  
Richland  
Saline  
Shelby  
St. Clair  
Union  
Wabash  
Washington  
Wayne  
White  
Williamson

## Indiana

Clark  
Crawford  
Daviess  
Dearborn  
Dubois  
Floyd  
Gibson  
Greene  
Harrison  
Jackson  
Jefferson  
Jennings  
Knox  
Lawrence  
Martin  
Monroe  
Ohio  
Orange  
Perry  
Pike

Posey  
Ripley  
Scott  
Spencer  
Sullivan  
Switzerland  
Vanderburgh  
Warrick  
Washington

## Kansas

All counties  
except:  
Cheyenne  
Cloud  
Decatur  
Ellis  
Gove  
Graham  
Greeley  
Hamilton  
Jewell  
Lane  
Logan  
Mitchell  
Ness  
Norton  
Osborne  
Phillips  
Rawlins  
Republic  
Rooks  
Scott  
Sheridan  
Sherman  
Smith  
Thomas  
Trego  
Wallace  
Wichita

## Kentucky

All counties

## Maryland

All counties  
except:  
Garrett

## Missouri

All counties  
except:  
Adair  
Andrew  
Atchison  
Buchanan  
Caldwell  
Chariton  
Clark  
Clinton  
Daviess  
DeKalb  
Gentry

Grundy  
Harrison  
Holt  
Knox  
Lewis  
Linn  
Livingston  
Macon  
Marion  
Mercer  
Nodaway  
Pike  
Putnam  
Ralls  
Schuyler  
Scotland  
Shelby  
Sullivan  
Worth

## New Jersey

All counties  
except:  
Bergen  
Hunterdon  
Mercer  
Morris  
Passaic  
Somerset  
Sussex  
Warren

## New Mexico

Bernalillo  
Cibola  
Curry  
DeBaca  
Grant  
Guadalupe  
Lincoln  
Quay  
Roosevelt  
Sierra  
Socorro  
Union  
Valencia

## New York

Bronx  
Kings  
Nassau  
New York  
Queens  
Richmond  
Suffolk  
Westchester

## North Carolina

Alamance  
Alexander  
Bertie  
Buncombe  
Burke

Caldwell  
Caswell  
Catawba  
Chatham  
Cherokee  
Clay  
Cleveland  
Davie  
Durham  
Forsyth  
Franklin  
Gates  
Graham  
Granville  
Guilford  
Halifax  
Harnett  
Haywood  
Henderson  
Hertford  
Iredell  
Jackson  
Lee  
Lincoln  
Macon  
Madison  
McDowell  
Nash  
Northampton  
Orange  
Person  
Polk  
Rockingham  
Rutherford  
Stokes  
Surry  
Swain  
Transylvania  
Vance  
Wake  
Warren  
Wilkes  
Yadkin

## Ohio

Adams  
Brown  
Clermont  
Gallia  
Hamilton  
Lawrence  
Pike  
Scioto  
Washington

## Oklahoma

Beaver  
Cimarron  
Texas  
Benton  
Clackamas

Clatsop  
Columbia  
Coos  
Curry  
Douglas  
Jackson  
Josephine  
Lane  
Lincoln  
Linn  
Marion  
Multnomah  
Polk  
Tillamook  
Washington  
Yamhill

## Pennsylvania

Bucks  
Chester  
Delaware  
Montgomery  
Philadelphia  
York

## Tennessee

All counties  
except:  
Chester  
Crockett  
Dyer  
Fayette  
Hardeman  
Hardin  
Haywood  
Henderson  
Lake  
Lauderdale  
Madison  
McNairy  
Shelby  
Tipton

## Texas

Armstrong  
Bailey  
Briscoe  
Carson  
Castro  
Cochran  
Dallas  
Deaf Smith  
Donley  
Floyd  
Gray  
Hale  
Hansford  
Hartley  
Hockley  
Hutchinson  
Lamb  
Lipscomb  
Moore

Ochiltree  
Oldham  
Parmer  
Potter  
Randall  
Roberts  
Sherman  
Swisher  
Yoakum

## Virginia

All counties

## Washington

Clallam  
Clark  
Cowlitz  
Grays Harbor  
Island  
Jefferson  
King  
Kitsap  
Lewis  
Mason  
Pacific  
Pierce  
San Juan  
Skagit  
Snohomish  
Thurston  
Wahkiakum  
Whatcom

## West Virginia

Berkeley  
Boone  
Braxton  
Cabell  
Calhoun  
Clay  
Gilmer  
Jackson  
Jefferson  
Kanawha  
Lincoln  
Logan  
Mason  
McDowell  
Mercer  
Mingo  
Monroe  
Morgan  
Pleasants  
Putnam  
Ritchie  
Roane  
Tyler  
Wayne  
Wirt  
Wood  
Wyoming

**Climate Zone 4 Recommendation Table**

	Item	Component	Recommendation	How-To's in Chapter 4
Envelope	Roof	Insulation entirely above deck	R-20 c.i.	EN2, 17, 20-21
		Metal building	R-13 + R-19	EN3, 17, 20-21
		Attic and other	R-38	EN4, 17-18, 20-21
		Single rafter	R-38	EN5, 17, 20-21
		Surface reflectance/emittance	No recommendation	
	Walls	Mass (HC > 7 Btu/ft <sup>2</sup> )	R-11.4 c.i.	EN6, 17, 20-21
		Metal building	R-13	EN7, 17, 20-21
		Steel framed	R-13 + R-7.5 c.i.	EN8, 17, 20-21
		Wood framed and other	R-13	EN9, 17, 20-21
		Below-grade walls	No recommendation	EN10, 17, 20-21
	Floors	Mass	R-8.3 c.i.	EN11, 17, 20-21
		Steel framed	R-30	EN12, 17, 20-21
		Wood framed and other	R-30	EN12, 17, 20-21
	Slabs	Unheated	No recommendation	EN17, 19-21
		Heated	R-7.5 for 24 in.	EN14, 17, 19-21
	Doors	Swinging	U-0.70	EN15, 20-21
		Non-swinging	U-0.50	EN16, 20-21
	Vertical Glazing	Window to wall ratio (WWR)	20% to 40% maximum	EN23, 36-37
Thermal transmittance		U-0.42	EN25	
Solar heat gain coefficient (SHGC)		N, S, E, W - 0.46 N only - 0.46	EN27-28	
Window orientation		$(A_N * SHGC_N + A_S * SHGC_S) > (A_E * SHGC_E + A_W * SHGC_W)$	A <sub>w</sub> —Window area for orientation x EN26-32	
Skylights	Exterior sun control (S, E, W only)	Projection factor 0.5	EN24, 28, 30, 36, 40, 42 DL5-6	
	Maximum percent of roof area	3%	DL5-7, DL8, DL13	
	Thermal transmittance	U-0.69	DL7, DL8, DL13	
	Solar heat gain coefficient (SHGC)	0.34	DL8, DL13	
Lighting	Interior Lighting	Lighting power density (LPD)	0.9 W/ft <sup>2</sup>	EL1-2, 4, 8, 10-16
		Light source (linear fluorescent)	90 mean lumens/watt	EL4, 9, 17
		Ballast	Electronic ballast	EL4
		Dimming controls for daylight Harvesting for WWR 25% or higher	Dim fixtures within 12 ft of N/S window wall or within 8 ft of skylight edge	DL1, 9-11, EL6-7
		Occupancy controls	Auto-off all unoccupied rooms	DL2, EL5, 6
		Interior room surface reflectances	80%+ on ceilings, 70%+ on walls and vertical partitions	DL3-4, EL3
HVAC	HVAC	Air conditioner (0-65 KBtuh)	13.0 SEER	HV1- 2, 4, 6, 12, 16-17, 20
		Air conditioner (>65-135 KBtuh)	11.0 EER/11.4 IPLV	HV1- 2, 4, 6, 12, 16-17, 20
		Air conditioner (>135-240 KBtuh)	10.8 EER/11.2 IPLV	HV1- 2, 4, 6, 12, 16-17, 20
		Air conditioner (>240 KBtuh)	10.0 EER/10.4 IPLV	HV1- 2, 4, 6, 12, 16-17, 20
		Gas furnace (0-225 KBtuh - SP)	80% AFUE or E <sub>t</sub>	HV1- 2, 6, 16, 20
		Gas furnace (0-225 KBtuh - Split)	80% AFUE or E <sub>t</sub>	HV1- 2, 6, 16, 20
		Gas furnace (>225 KBtuh)	80% E <sub>c</sub>	HV1- 2, 6, 16, 20
		Heat pump (0-65 KBtuh)	13.0 SEER/7.7 HSPF	HV1- 2, 4, 6, 12, 16-17, 20
		Heat pump (>65-135 KBtuh)	10.6 EER/11.0 IPLV/3.2 COP	HV1- 2, 4, 6, 12, 16-17, 20
	Heat pump (>135 KBtuh)	10.1 EER/11.0 IPLV/3.1 COP	HV1- 2, 4, 6, 12, 16-17, 20	
	Economizer	Air conditioners & heat pumps - SP	Cooling capacity > 54 KBtuh	HV23
Ventilation	Outdoor air damper	Motorized control	HV7-8	
	Demand control	CO <sub>2</sub> sensors	HV7, 22	
Ducts	Friction rate	0.08 in. w.c./100 feet	HV9, 18	
	Sealing	Seal class B	HV11	
	Location	Interior only	HV9	
	Insulation level	R-6	HV10	
SWH	Service Water Heating	Gas storage	90% E <sub>t</sub>	WH1-4
		Gas instantaneous	0.81 EF or 81% E <sub>t</sub>	WH1-4
		Electric storage 12 kW	EF > 0.99 – 0.0012xVolume	WH1-4
		Pipe insulation (d<1½ in./ d≥1½ in.)	1 in./ 1½ in.	WH6

**Note:** If the table contains “No recommendation” for a component, the user must meet the more stringent of either Standard 90.1 or the local code requirements in order to reach the 30% savings target.



Photographs courtesy of Tom Bender

**Figure 3-13.** Energy-efficient office equipment and flat-screen computer monitors minimize energy and heat loads, in addition to adding critical workspace at each installation, in the Bank of Astoria.

## Zone 4—Bank of Astoria

MANZANITA, ORE.

The Bank of Astoria is not a typical financial institution. Nestled on a wooded landscape in Manzanita, the bank does more than just handle financial matters. Designed by architect Tom Bender, it is a building that exhibits a wealth of sustainable elements.

Site location and building orientation were taken advantage of to allow south-facing windows and skylights for solar gain. Windows and skylights provide inviting views into the building and from the building into its entry garden. In addition, the windows and skylights provide 100 percent daylighting to all areas of the bank, except the vault. The windows are all occupant-controlled and provide 100 percent of ventilation needs. No air conditioning is used with the building; instead, a night-flushing ventilation system is used to pre-cool the building with the region's cool nighttime air. The system incorporates a high-level exhaust vent that uses gravity to vent hot air from the building, maintaining interior air temperatures at comfortable levels.

Siltation blockage of permeable paving was a concern, which led to two separate demonstration techniques. The first is a prefab plastic infiltration vault system under the drive-through paving. In the second system, water from the roof is discharged through a

---

This example building demonstrates good design and construction practices suitable for this particular climate zone. In some cases, the example building may have incorporated additional features that go beyond the scope of the recommendations of this Guide.





**Figure 3-14.** Water from the roof is discharged through a scupper into a landscaping pond for storage and settling before the water is reabsorbed into sandfill below.



**Figure 3-15.** South-facing windows and skylights provide inviting views into the building and from the building into its entry garden.



**Figure 3-16.** All cabinetry and partitions in the building, with the exception of teller steel, were built locally from local materials.

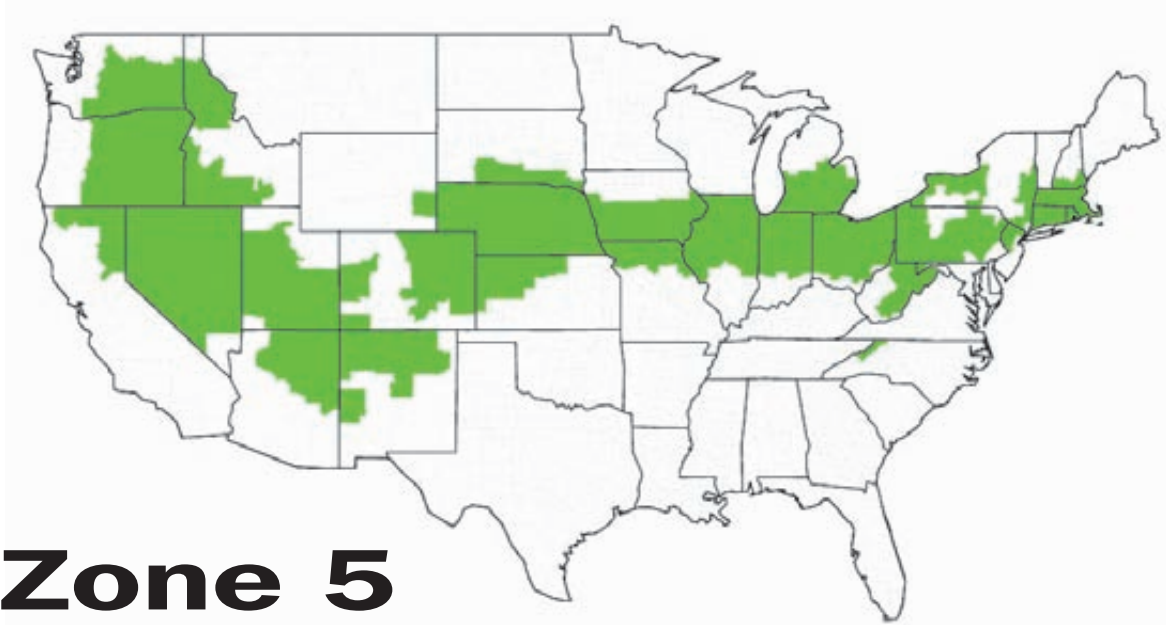

**Figure 3-17.** Skylights and windows provide an aggregate of twice the already stringent Oregon code standards for energy efficiency.

scupper into a landscaping pond for storage and settling before the water is reabsorbed into sandfill below. With the region's high rainfall, stormwater is transformed into something to be celebrated and enjoyed rather than hidden in pipes.

Building envelope efficiency was achieved with R-21 walls, R-38 floors and roof, U.30 windows, and U.38 skylights. As a result, the building provides an aggregate of twice the already stringent Oregon code standards for energy efficiency.

Inside the building, all cabinetry and partitions, except the teller steel, were built locally, from local materials. Eighty-five percent of the county the building is in is part of the world's most productive timber-growing area. Wherever possible, minimally processed, nontoxic, and recycled-content materials were used, including driftwood posts and door handles, natural linoleum and slate flooring, low-toxicity paints and wood finishes, and recycled desks and carpet pads. The resulting product is a building that honors its natural community and its resources.



# Zone 5

## Arizona

Apache  
Coconino  
Navajo

## California

Lassen  
Modoc  
Nevada  
Plumas  
Sierra  
Siskiyou

## Colorado

Adams  
Arapahoe  
Bent  
Boulder  
Cheyenne  
Crowley  
Delta  
Denver  
Douglas  
Elbert  
El Paso  
Fremont  
Garfield  
Gilpin  
Huerfano  
Jefferson  
Kiowa  
Kit Carson  
La Plata  
Larimer  
Lincoln  
Logan  
Mesa  
Montezuma  
Montrose  
Morgan  
Phillips  
Prowers  
Pueblo  
Sedgwick  
Teller  
Washington  
Weld  
Yuma

## Connecticut

All counties

## Idaho

Ada  
Benewah  
Canyon  
Cassia  
Clearwater  
Elmore  
Gem  
Gooding  
Idaho  
Jerome  
Kootenai  
Latah

Lewis  
Lincoln  
Minidoka  
Nez Perce  
Owyhee  
Payette  
Power  
Shoshone  
Twin Falls  
Washington

## Illinois

All counties  
except:  
Alexander  
Bond  
Christian  
Clay  
Clinton  
Crawford  
Edwards  
Effingham  
Fayette  
Franklin  
Gallatin  
Hamilton  
Hardin  
Jackson  
Jasper  
Jefferson  
Johnson  
Lawrence  
Macoupin  
Madison  
Marion  
Massac  
Monroe  
Montgomery

Perry  
Pope  
Pulaski  
Randolph  
Richland  
Saline  
Shelby  
St. Clair  
Union  
Wabash  
Washington  
Wayne  
White  
Williamson  
Brown

## Indiana

All counties  
except:  
Clark  
Crawford  
Davies  
Dearborn  
Dubois  
Floyd  
Gibson  
Greene  
Harrison

Jackson  
Jefferson  
Jennings  
Knox  
Lawrence  
Martin  
Monroe  
Ohio  
Orange  
Perry  
Pike  
Posey  
Ripley  
Scott  
Spencer  
Sullivan  
Switzerland  
Vanderburgh  
Warrick  
Washington

## Iowa

All counties  
except:  
Allamakee  
Black Hawk  
Bremer  
Buchanan  
Buena Vista  
Butler  
Calhoun  
Cerro Gordo  
Cherokee  
Chickasaw  
Clayton  
Delaware  
Dickinson  
Emmet  
Fayette  
Floyd  
Franklin  
Grundy  
Hamilton  
Hancock  
Hardin  
Howard  
Humboldt  
Ida  
Kossuth  
Lyon  
Mitchell  
O'Brien  
Osceola  
Palo Alto  
Plymouth  
Pocahontas  
Sac  
Sioux  
Webster

Winneshiek  
Worth  
Wright

## Kansas

Cheyenne  
Cloud  
Decatur  
Ellis  
Gove  
Graham  
Greeley  
Hamilton  
Jewell  
Lane  
Logan  
Mitchell  
Ness  
Norton  
Osborne  
Phillips  
Rawlins  
Republic  
Rooks  
Scott  
Sheridan  
Sherman  
Smith  
Thomas  
Trego  
Wallace  
Wichita

## Maryland

Garrett

## Massachusetts

All counties

## Michigan

Allegan  
Barry  
Bay  
Berrien  
Branch  
Calhoun  
Cass  
Clinton  
Eaton  
Genesee  
Gratiot  
Hillsdale  
Ingham  
Ionia  
Jackson  
Kalamazoo  
Kent  
Lapeer  
Lenawee  
Livingston  
Macomb  
Midland  
Monroe  
Montcalm

Muskegon  
Oakland  
Ottawa  
Saginaw  
Shiawassee  
St. Clair  
St. Joseph  
Tuscola  
Van Buren  
Washtenaw  
Wayne

## Missouri

Adair  
Andrew  
Atchison  
Buchanan  
Caldwell  
Chariton  
Clark  
Clinton  
Daviess  
DeKalb  
Gentry  
Grundy  
Harrison  
Holt  
Knox  
Lewis  
Linn  
Livingston  
Macon  
Marion  
Mercer  
Nodaway  
Pike  
Putnam  
Ralls  
Schuyler  
Scotland  
Shelby  
Sullivan  
Worth

## Nebraska

All counties

## Nevada

All counties  
except:  
Clark

## New Hampshire

Cheshire  
Hillsborough  
Rockingham  
Strafford

## New Jersey

Bergen  
Hunterdon  
Mercer  
Morris  
Passaic  
Somerset

Sussex  
Warren

## New Mexico

Catron  
Colfax  
Harding  
Los Alamos  
McKinley  
Mora  
Rio Arriba  
Sandoval  
San Juan  
San Miguel  
Santa Fe  
Taos  
Torrance

## New York

Albany  
Cayuga  
Chautauqua  
Chemung  
Columbia  
Cortland  
Dutchess  
Erie  
Genesee  
Greene  
Livingston  
Monroe  
Niagara  
Onondaga  
Ontario  
Orange  
Orleans  
Oswego  
Putnam  
Rensselaer  
Rockland  
Saratoga  
Schenectady  
Seneca  
Tioga  
Washington  
Wayne  
Yates

## North Carolina

Alleghany  
Ashe  
Avery  
Mitchell  
Watauga  
Yancey

## Ohio

All counties  
except:  
Adams  
Brown  
Clermont  
Gallia  
Hamilton  
Lawrence

Pike  
Scioto  
Washington

## Oregon

Baker  
Crook  
Deschutes  
Gilliam  
Grant  
Harney  
Hood River  
Jefferson  
Klamath  
Lake  
Malheur  
Morrow  
Sherman  
Umatilla  
Union  
Wallowa  
Wasco  
Wheeler

## Pennsylvania

All counties  
except:  
Bucks  
Cameron  
Chester  
Clearfield  
Delaware  
Elk  
McKean  
Montgomery  
Philadelphia  
Potter  
Susquehanna  
Tioga  
Wayne  
York

## Rhode Island

All counties

## South Dakota

Bennett  
Bon Homme  
Charles Mix  
Clay  
Douglas  
Gregory  
Hutchinson  
Jackson  
Mellette  
Todd  
Tripp  
Union  
Yankton

## Utah

All counties  
except:  
Box Elder  
Cache

Carbon  
Daggett  
Duchesne  
Morgan  
Rich  
Summit  
Uintah  
Wasatch  
Washington

## Washington

Adams  
Asotin  
Benton  
Chelan  
Columbia  
Douglas  
Franklin  
Garfield  
Grant  
Kittitas  
Lincoln  
Skamania  
Spokane  
Walla Walla  
Whitman  
Yakima

## Wyoming

Goshen  
Platte

## West Virginia

Barbour  
Brooke  
Doddridge  
Fayette  
Grant  
Greenbrier  
Hampshire  
Hancock  
Hardy  
Harrison  
Lewis  
Marion  
Marshall  
Mineral  
Monongalia  
Nicholas  
Ohio  
Pendleton  
Pocahontas  
Preston  
Raleigh  
Randolph  
Summers  
Taylor  
Tucker  
Upshur  
Webster  
Wetzel

Climate Zone 5 Recommendation Table

	Item	Component	Recommendation	How-To's in Chapter 4
Envelope	Roof	Insulation entirely above deck	R-20 c.i.	EN2, 17, 20-21
		Metal building	R-13 + R-19	EN3, 17, 20-21
		Attic and other	R-38	EN4, 17-18, 20-21
		Single rafter	R-38 + R-5 c.i.	EN5, 17, 20-21
		Surface reflectance/emittance	No recommendation	
	Walls	Mass (HC > 7 Btu/ft <sup>2</sup> )	R-11.4 c.i.	EN6, 17, 20-21
		Metal building	R-13 + R-13	EN7, 17, 20-21
		Steel framed	R-13 + R-7.5 c.i.	EN8, 17, 20-21
		Wood framed and other	R-13 + R-3.8 c.i.	EN9, 17, 20-21
		Below-grade walls	R-7.5 c.i.	EN10, 17, 20-21
	Floors	Mass	R-10.4 c.i.	EN11, 17, 20-21
		Steel framed	R-30	EN12, 17, 20-21
		Wood framed and other	R-30	EN12, 17, 20-21
	Slabs	Unheated	No recommendation	EN17, 19-21
		Heated	R-10 for 36 in.	EN14, 17, 19-21
	Doors	Swinging	U-0.70	EN15, 20-21
		Non-swinging	U-0.50	EN16, 20-21
	Vertical Glazing	Window to wall ratio (WWR)	20% to 40% maximum	EN23, 36-37
Thermal transmittance		U-0.42	EN25, 31	
Solar heat gain coefficient (SHGC)		N, S, E, W - 0.46 N only - 0.46	EN27-28	
Window orientation		$(A_N * SHGC_N + A_S * SHGC_S) > (A_E * SHGC_E + A_W * SHGC_W)$	A <sub>x</sub> —Window area for orientation x EN26-32	
Exterior sun control (S, E, W only)		Projection factor 0.5	EN24, 28, 30, 36, 40, 42 DL5-6	
Skylights	Maximum percent of roof area	3%	DL5-7, DL8, DL13	
	Thermal transmittance	U-0.69	DL7, DL8, DL13	
	Solar heat gain coefficient (SHGC)	0.39	DL8, DL13	
Lighting	Interior Lighting	Lighting power density (LPD)	0.9 W/ft <sup>2</sup>	EL1-2, 4, 8, 10-16
		Light source (linear fluorescent)	90 mean lumens/watt	EL4, 9, 17
		Ballast	Electronic ballast	EL4
		Dimming controls for daylight harvesting for WWR 25% or higher	Dim fixtures within 12 ft of N/S window wall or within 8 ft of skylight edge	DL1, 9-11, EL6-7
		Occupancy controls	Auto-off all unoccupied rooms	DL2, EL5, 6
		Interior room surface reflectances	80%+ on ceilings, 70%+ on walls and vertical partitions	DL3-4, EL3
HVAC	HVAC	Air conditioner (0-65 KBtuh)	13.0 SEER	HV1- 2, 4, 6, 12, 16-17, 20
		Air conditioner (>65-135 KBtuh)	11.0 EER/11.4 IPLV	HV1- 2, 4, 6, 12, 16-17, 20
		Air conditioner (>135-240 KBtuh)	10.8 EER/11.2 IPLV	HV1- 2, 4, 6, 12, 16-17, 20
		Air conditioner (>240 KBtuh)	10.0 EER/10.4 IPLV	HV1- 2, 4, 6, 12, 16-17, 20
		Gas furnace (0-225 KBtuh - SP)	80% AFUE or E <sub>t</sub>	HV1- 2, 6, 16, 20
		Gas furnace (0-225 KBtuh - Split)	90% AFUE or E <sub>t</sub>	HV1- 2, 6, 16, 20
		Gas furnace (>225 KBtuh)	80% E <sub>c</sub>	HV1- 2, 6, 16, 20
		Heat pump (0-65 KBtuh)	13.0 SEER/7.7 HSPF	HV1- 2, 4, 6, 12, 16-17, 20
		Heat pump (>65-135 KBtuh)	10.6 EER/11.0 IPLV/3.2 COP	HV1- 2, 4, 6, 12, 16-17, 20
	Heat pump (>135 KBtuh)	10.1 EER/11.0 IPLV/3.1 COP	HV1- 2, 4, 6, 12, 16-17, 20	
	Economizer	Air conditioners & heat pumps - SP	Cooling capacity > 54 KBtuh	HV23
Ventilation	Outdoor air damper	Motorized control	HV7-8	
	Demand control	CO <sub>2</sub> sensors	HV7, 22	
Ducts	Friction rate	0.08 in. w.c./100 feet	HV9, 18	
	Sealing	Seal class B	HV11	
	Location	Interior only	HV9	
	Insulation level	R-6	HV10	
SWH	Service Water Heating	Gas storage	90% E <sub>t</sub>	WH1-4
		Gas instantaneous	0.81 EF or 81% E <sub>t</sub>	WH1-4
		Electric storage 12 kW	EF > 0.99 – 0.0012xVolume	WH1-4
		Pipe insulation (d<1½ in./ d≥1½ in.)	1 in./ 1½ in.	WH6

**Note:** If the table contains “No recommendation” for a component, the user must meet the more stringent of either Standard 90.1 or the local code requirements in order to reach the 30% savings target.



Photographs courtesy of Judy Watts Wilson

**Figure 3-18.** The Gilman Ordway Building at the Woods Hole Research Center is a creative addition of contemporary office space that preserves the original building's traditional appearance.

## Zone 5—Gilman Ordway Building at the Woods Hole Research Center

FALMOUTH, MASS.

During its cold winters, rain, snow, and ice damming in Zone 5 can threaten a building's envelope. Thus, controlling moisture and air flow in the building envelope in this zone is critical to designing and building a durable, comfortable office building. In response, the Gilman Ordway Building, part of the Woods Hole Research Center, uses an environmentally intelligent design to create a healthy, comfortable workplace.

Although the Gilman Ordway Building uses a wide variety of passive and active environmental strategies, their integration was fundamental to the building's success. Because of the center's interest in reversing the progress of global warming, the design team at William McDonough + Partners decided the building would operate without burning such fossil fuels as gas, oil, or coal on-site, instead using renewable sources of energy while aspiring to produce more energy than it consumed on an annual basis. Thus, the all-electric building relies on renewable energy sources, including an on-site

---

This example building demonstrates good design and construction practices suitable for this particular climate zone. In some cases, the example building may have incorporated additional features that go beyond the scope of the recommendations of this Guide.



**Figure 3-19.** A simple interior materials palette of glass, stone, and wood provides a healthy environment for the building's occupants.

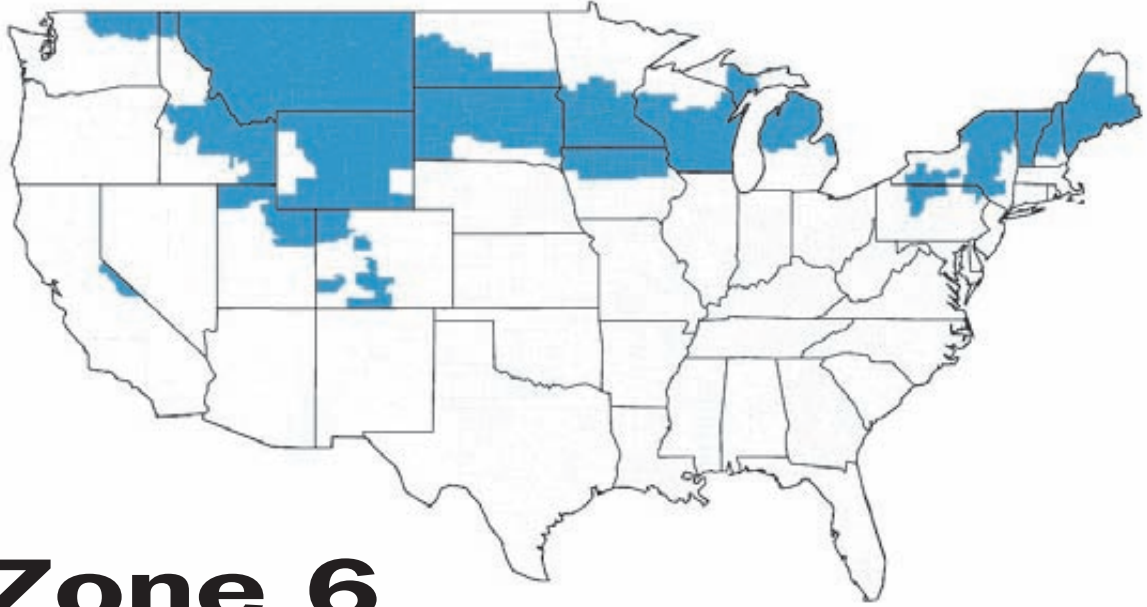

**Figure 3-20.** Large exterior windows and high ceilings increase daylighting.

photovoltaic array that powers the building's closed-loop ground-source heat pump system. Careful detailing of the envelope optimizes use of these resources—the building is well-insulated, with an extremely secure envelope.

Through careful siting, the building's design and location take advantage of natural features to achieve thermal comfort. The 19,200-square-foot office building is elongated along an east-west axis to gain optimal solar energy. Skylights and full-height windows provide abundant daylight and access to views, while ventilation systems and operable windows supply fresh air. A temperature and humidity monitoring system further enhances indoor environmental quality.

The predominance of natural wood finishes both inside and out and the preservation of the original building's traditional appearance give the center a warmth and character familiar to its New England setting. Visitors within its comfortable, gracious spaces do not immediately recognize the office building as an advanced, high-performance building. The integration of new technology and New England sensibility is one of the building's great successes.



# Zone 6

## California

Alpine  
Mono

## Colorado

Alamosa  
Archuleta  
Chaffee  
Conejos  
Costilla  
Custer  
Dolores  
Eagle  
Moffat  
Ouray  
Rio Blanco  
Saguache  
San Miguel

## Idaho

Adams  
Bannock  
Bear Lake  
Bingham  
Blaine  
Boise  
Bonner  
Bonneville  
Boundary  
Butte  
Camas  
Caribou  
Clark  
Custer  
Franklin  
Fremont  
Jefferson  
Lemhi  
Madison  
Oneida  
Teton  
Valley

## Iowa

Allamakee  
Black Hawk

Bremer  
Buchanan  
Buena Vista  
Butler  
Calhoun  
Cerro Gordo  
Cherokee  
Chickasaw  
Clay  
Clayton  
Delaware  
Dickinson  
Emmet  
Fayette  
Floyd  
Franklin  
Grundy  
Hamilton  
Hancock  
Hardin  
Howard  
Humboldt  
Ida  
Kossuth  
Lyon  
Mitchell  
O'Brien  
Osceola  
Palo Alto  
Plymouth  
Pocahontas  
Sac  
Sioux  
Webster  
Winnebago  
Winneshiak  
Worth  
Wright

## Maine

*All counties  
except:  
Aroostook*

## Michigan

Alcona  
Alger

Alpena  
Antrim  
Arenac  
Benzie  
Charlevoix  
Cheboygan  
Clare  
Crawford  
Delta  
Dickinson  
Emmet  
Gladwin  
Grand Traverse  
Huron  
Iosco  
Isabella  
Kalkaska  
Lake  
Leelanau  
Manistee  
Marquette  
Mason  
Mecosta  
Menominee  
Missaukee  
Montmorency  
Newaygo  
Oceana  
Ogemaw  
Osceola  
Oscoda  
Otsego  
Presque Isle  
Roscommon  
Sanilac  
Wexford

## Minnesota

Anoka  
Benton  
Big Stone  
Blue Earth  
Brown  
Carver  
Chippewa  
Chisago  
Cottonwood  
Dakota

Dodge  
Douglas  
Faribault  
Fillmore  
Freeborn  
Goodhue  
Hennepin  
Houston  
Isanti  
Jackson  
Kandiyohi  
Lac qui Parle  
Le Sueur  
Lincoln  
Lyon  
Martin  
McLeod  
Meeker  
Morrison  
Mower  
Murray  
Nicollet  
Nobles  
Olmsted  
Pipestone  
Pope  
Ramsey  
Redwood  
Renville  
Rice  
Rock  
Scott  
Sherburne  
Sibley  
Stearns  
Steele  
Stevens  
Swift  
Todd  
Traverse  
Wabasha  
Waseca  
Washington  
Watonwan  
Winona  
Wright  
Yellow Medicine

## Montana

All counties

## New Hampshire

Belknap  
Carroll  
Coos  
Grafton  
Merrimack  
Sullivan

## New York

Allegany  
Broome  
Cattaraugus  
Chenango  
Clinton  
Delaware  
Essex  
Franklin  
Fulton  
Hamilton  
Herkimer  
Jefferson  
Lewis  
Madison  
Montgomery  
Oneida  
Otsego  
Schoharie  
Schuyler  
Steuben  
St. Lawrence  
Sullivan  
Tompkins  
Ulster  
Warren  
Wyoming

## North Dakota

Adams  
Billings  
Bowman  
Burleigh  
Dickey  
Dunn

Emmons  
Golden Valley  
Grant  
Hettinger  
LaMoure  
Logan  
McIntosh  
McKenzie  
Mercer  
Morton  
Oliver  
Ransom  
Richland  
Sargent  
Sioux  
Slope  
Stark

## Pennsylvania

Cameron  
Clearfield  
Elk  
McKean  
Potter  
Susquehanna  
Tioga  
Wayne

## South Dakota

*All counties  
except:  
Bennett  
Bon Homme  
Charles Mix  
Clay  
Douglas  
Gregory  
Hutchinson  
Jackson  
Mellette  
Todd  
Tripp  
Union  
Yankton*

## Utah

Box Elder  
Cache

Carbon  
Daggett  
Duchesne  
Morgan  
Rich  
Summit  
Uintah  
Wasatch

## Vermont

All counties

## Washington

Ferry  
Okanogan  
Pend Oreille  
Stevens

## Wisconsin

*All counties  
except:  
Ashland  
Bayfield  
Burnett  
Douglas  
Florence  
Forest  
Iron  
Langlade  
Lincoln  
Oneida  
Price  
Sawyer  
Taylor  
Vilas  
Washburn*

## Wyoming

*All counties  
except:  
Goshen  
Platte  
Lincoln  
Sublette  
Teton*

Climate Zone 6 Recommendation Table

	Item	Component	Recommendation	How-To's in Chapter 4
Envelope	Roof	Insulation entirely above deck	R-20 c.i.	EN2, 17, 20-21
		Metal building	R-13 + R-19	EN3, 17, 20-21
		Attic and other	R-38	EN4, 17-18, 20-21
		Single rafter	R-38 + R-5 c.i.	EN5, 17, 20-21
		Surface reflectance/emittance	No recommendation	
	Walls	Mass (HC > 7 Btu/ft <sup>2</sup> )	R-11.4 c.i.	EN6, 17, 20-21
		Metal building	R-13 + R-13	EN7, 17, 20-21
		Steel framed	R-13 + R-7.5 c.i.	EN8, 17, 20-21
		Wood framed and other	R-13 + R-3.8 c.i.	EN9, 17, 20-21
		Below grade walls	R-7.5 c.i.	EN10, 17, 20-21
	Floors	Mass	R-10.4 c.i.	EN11, 17, 20-21
		Steel framed	R-30	EN12, 17, 20-21
		Wood framed and other	R-30	EN12, 17, 20-21
	Slabs	Unheated	R-10 for 24 in	EN13, 17, 19-21
		Heated	R-10 for 36 in.	EN14, 17, 19-21
	Doors	Swinging	U-0.70	EN15, 20-21
		Non-swinging	U-0.50	EN16, 20-21
	Vertical Glazing	Window to wall ratio (WWR)	20% to 40% maximum	EN23, 36-37
		Thermal transmittance	U-0.42	EN25, 31
		Solar heat gain coefficient (SHGC)	N, S, E, W - 0.46 N only - 0.46	EN27-28
Window orientation		$(A_N * SHGC_N + A_S * SHGC_S) > (A_E * SHGC_E + A_W * SHGC_W)$	A <sub>x</sub> —Window area for orientation x EN26-32	
Exterior sun control (S, E, W only)		No recommendation	EN24, 28, 30, 36, 40, 42 DL5-6	
Skylights	Maximum percent of roof area	3%	DL5-7, DL8, DL13	
	Thermal transmittance	U-0.69	DL7, DL8, DL13	
	Solar heat gain coefficient (SHGC)	0.49	DL8, DL13	
Lighting	Interior Lighting	Lighting power density (LPD)	0.9 W/ft <sup>2</sup>	EL1-2, 4, 8, 10-16
		Light source (linear fluorescent)	90 mean lumens/watt	EL4, 9, 17
		Ballast	Electronic ballast	EL4
		Dimming controls for daylight harvesting for WWR 25% or higher	Dim fixtures within 12 ft of N/S window wall or within 8 ft of skylight edge	DL1, 9-11, EL6-7
		Occupancy controls	Auto-off all unoccupied rooms	DL2, EL5, 6
		Interior room surface reflectances	80%+ on ceilings, 70%+ on walls and vertical partitions	DL3-4, EL3
HVAC	HVAC	Air conditioner (0-65 KBtuh)	13.0 SEER	HV1- 2, 4, 6, 12, 16-17, 20
		Air conditioner (>65-135 KBtuh)	No recommendation	HV1- 2, 4, 6, 12, 16-17, 20
		Air conditioner (>135-240 KBtuh)	No recommendation	HV1- 2, 4, 6, 12, 16-17, 20
		Air conditioner (>240 KBtuh)	No recommendation	HV1- 2, 4, 6, 12, 16-17, 20
		Gas furnace (0-225 KBtuh - SP)	80% AFUE or E <sub>t</sub>	HV1- 2, 6, 16, 20
		Gas furnace (0-225 KBtuh - Split)	90% AFUE or E <sub>t</sub>	HV1- 2, 6, 16, 20
		Gas furnace (>225 KBtuh)	80% E <sub>c</sub>	HV1- 2, 6, 16, 20
		Heat pump (0-65 KBtuh)	13.0 SEER/7.7 HSPF	HV1- 2, 4, 6, 12, 16-17, 20
		Heat pump (>65-135 KBtuh)	No recommendation	HV1- 2, 4, 6, 12, 16-17, 20
	Heat pump (>135 KBtuh)	No recommendation	HV1- 2, 4, 6, 12, 16-17, 20	
	Economizer	Air conditioners & heat pumps - SP	Cooling capacity > 54 KBtuh	HV23
	Ventilation	Outdoor air damper	Motorized control	HV7-8
		Demand control	CO <sub>2</sub> sensors	HV7, 22
		Location	Interior only	HV9
	Ducts	Friction rate	0.08 in. w.c./100 feet	HV9, 18
Sealing		Seal class B	HV11	
Insulation level		R-6	HV10	
SWH	SWH	Gas storage	90% E <sub>t</sub>	WH1-4
		Gas instantaneous	0.81 EF or 81% E <sub>t</sub>	WH1-4
		Electric storage 12 kW	EF > 0.99 – 0.0012xVolume	WH1-4
		Pipe insulation (d<1½ in./ d≥1½ in.)	1 in./ 1½ in.	WH6

**Note:** If the table contains “No recommendation” for a component, the user must meet the more stringent of either Standard 90.1 or the local code requirements in order to reach the 30% savings target.



Photographs courtesy of Alex Wilson

**Figure 3-21.** In keeping with the organization’s mission and the nature of its work, the French Wing of the Society for the Protection of New Hampshire Forests used local trees from the site to help build the new wing.

## Zone 6—Society for the Protection of New Hampshire Forests, French Wing

CONCORD, N.H.

The French Wing, an addition to the Society for the Protection of New Hampshire Forests’ headquarters, showcases several innovations in conservation and sustainable design for architects working on projects in this very cold climate.

A 1998 renovation of the headquarters included installation of a photovoltaic array and wood-chip boiler, both of which now contribute to the French Wing. In keeping with the society’s mission and the nature of its work, the wing itself features other energy-conserving technologies as well. A south-facing clerestory, which runs the length of the wing, and four moderate-sized north-facing skylights illuminate a two-story atrium. Each office is lit with lighting from two outside windows. To give occupants even lighting throughout their offices, the windows are placed close to the side walls. High-efficiency, occupancy-sensor-controlled single-lamp fluorescent fixtures and task lighting are used in the offices. Occupancy sensors are used in the kitchen, bathrooms, copier room, and conference rooms. Airtight construction, in combination with R-25 walls and R-42 roof, are key to achieving the wing’s low heating requirement.

---

This example building demonstrates good design and construction practices suitable for this particular climate zone. In some cases, the example building may have incorporated additional features that go beyond the scope of the recommendations of this Guide.





**Figure 3-22.** North-facing skylights illuminate the French Wing's corridor.



**Figure 3-23.** A graywater system provides water for interior planters in the French Wing.

The integration of daylighting, efficient artificial lighting, and building envelope allow the building to achieve energy usage 60 percent below the ASHRAE 90.1 baseline.

Water conservation is addressed by use of composting toilets and recycled graywater pumped to planters surrounding the atrium at the second floor and then to a wild-flower garden. No septic system is required. The result of the water-saving technologies is a 90 percent water reduction of the baseline building modeled using the Energy Policy Act of 1992.

Placing the wood-chip boiler in a separate building eliminates all combustion from the building. Electricity is used in place of gas for the kitchen range and summertime water heating. A central heat-recovery ventilator is in the building's basement and provides ducted fresh air to all the offices.

In the short, mild summers of Zone 6, the building is cooled by a whole-building fan that is turned on at night and off in the morning. Only the copier room has mechanical air conditioning.

Given the purpose of the society, the designers, Banwell Architects, gave much attention to the origin of the woods used in the wing. White pine used for structure came from the site itself—a handful of towering trees had to be removed to make way for the addition. Most of the finished wood, including paneling, cabinets, and flooring, came from forests certified by the Forest Steward Council. Even the wood chips used in the heating plant are certified. The resulting product is a state-of-the-art workplace.

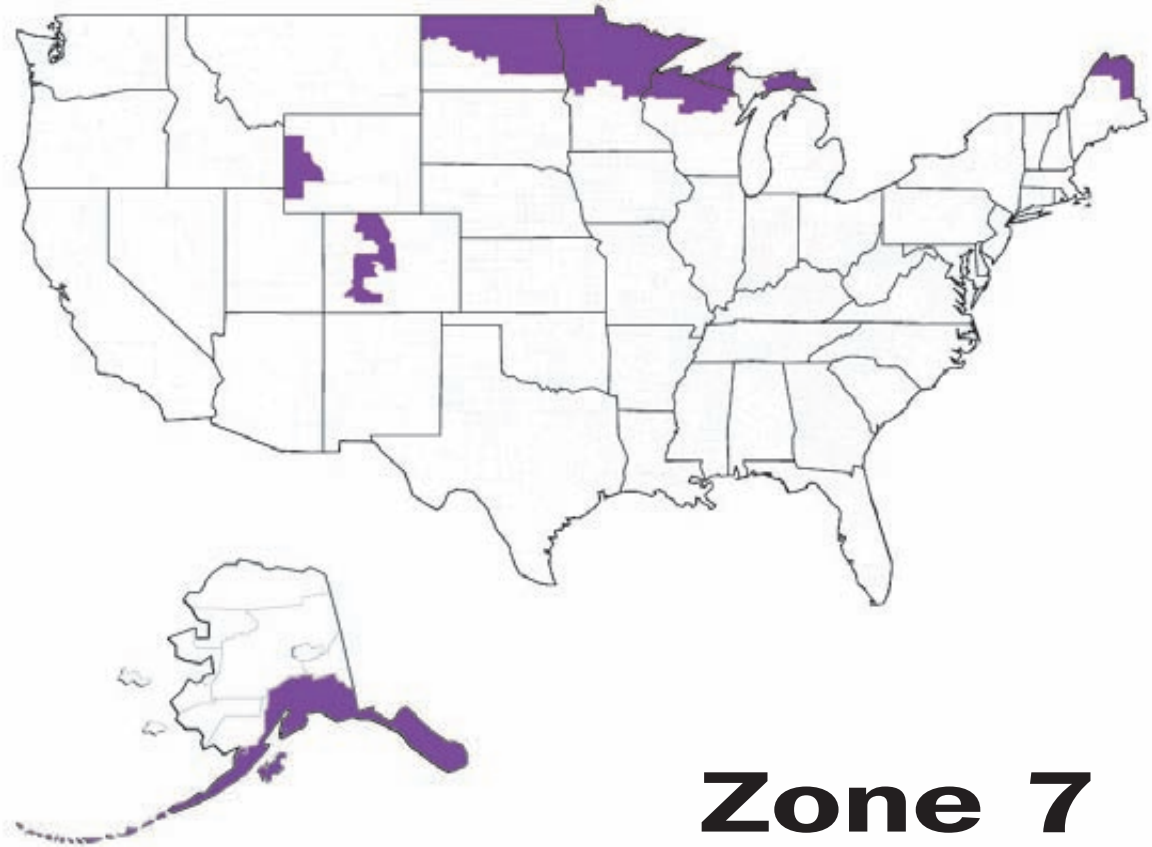

# Zone 7

## Alaska

Aleutians East  
 Aleutians West (CA)  
 Anchorage  
 Angoon (CA)  
 Bristol Bay  
 Denali  
 Haines  
 Juneau  
 Kenai Peninsula  
 Ketchikan (CA)  
 Ketchikan Gateway  
 Kodiak Island  
 Lake and Peninsula  
 Matanuska-Susitna  
 Prince of Wales-Outer  
 Sitka  
 Skagway-Hoonah-  
 Valdez-Cordova (CA)  
 Wrangell-Petersburg (CA)  
 Yakutat

## Colorado

Clear Creek  
 Grand  
 Gunnison  
 Hinsdale  
 Jackson  
 Lake  
 Mineral  
 Park  
 Pitkin  
 Rio Grande  
 Routt  
 San Juan

Summit

## Maine

Aroostook

## Michigan

Baraga  
 Chippewa  
 Gogebic  
 Houghton  
 Iron  
 Keweenaw  
 Luce  
 Mackinac  
 Ontonagon  
 Schoolcraft

## Minnesota

Aitkin  
 Becker  
 Beltrami  
 Carlton  
 Cass  
 Clay  
 Clearwater  
 Cook  
 Crow Wing  
 Grant  
 Hubbard  
 Itasca  
 Kanabec  
 Kittson  
 Koochiching  
 Lake

Lake of the Woods  
 Mahanomen  
 Marshall  
 Mille Lacs  
 Norman  
 Otter Tail  
 Pennington  
 Pine  
 Polk  
 Red Lake  
 Roseau  
 St. Louis  
 Wadena  
 Wilkin

## North Dakota

Barnes  
 Benson  
 Bottineau  
 Burke  
 Cass  
 Cavalier  
 Divide  
 Eddy  
 Foster  
 Grand Forks  
 Griggs  
 Kidder  
 McHenry  
 McLean  
 Mountrail  
 Nelson  
 Pembina  
 Pierce  
 Ramsey  
 Renville

Rolette  
 Sheridan  
 Steele  
 Stutsman  
 Towner  
 Traill  
 Walsh  
 Ward  
 Wells  
 Williams

## Wisconsin

Ashland  
 Bayfield  
 Burnett  
 Douglas  
 Florence  
 Forest  
 Iron  
 Langlade  
 Lincoln  
 Oneida  
 Price  
 Sawyer  
 Taylor  
 Vilas  
 Washburn

## Wyoming

Lincoln  
 Sublette  
 Teton

**Climate Zone 7 Recommendation Table**

	Item	Component	Recommendation	How-To's in Chapter 4
Envelope	Roof	Insulation entirely above deck	R-20 c.i.	EN2, 17, 20-21
		Metal building	R-13 + R-19	EN3, 17, 20-21
		Attic and other	R-60	EN4, 17-18, 20-21
		Single rafter	R-38 + R-10 c.i.	EN5, 17, 20-21
		Surface reflectance/emittance	No recommendation	
	Walls	Mass (HC > 7 Btu/ft <sup>2</sup> )	R-15.2 c.i.	EN6, 17, 20-21
		Metal building	R-13 + R-13	EN7, 17, 20-21
		Steel framed	R-13 + R-7.5 c.i.	EN8, 17, 20-21
		Wood framed and other	R-13 + R-7.5 c.i.	EN9, 17, 20-21
		Below grade walls	R-7.5 c.i.	EN10, 17, 20-21
	Floors	Mass	R-12.5 c.i.	EN11, 17, 20-21
		Steel framed	R-38	EN12, 17, 20-21
		Wood framed and other	R-30	EN12, 17, 20-21
	Slabs	Unheated	R-15 for 24 in	EN13, 17, 19-21
		Heated	R-15 Full slab	EN14, 17, 19-21
	Doors	Swinging	U-0.50	EN15, 20-21
		Non-swinging	U-0.50	EN16, 20-21
	Vertical Glazing	Window to wall ratio (WWR)	20% to 40% maximum	EN23, 36-37
		Thermal transmittance	U-0.33	EN25, 31
		Solar heat gain coefficient (SHGC)	N, S, E, W N only No recommendation	
Window orientation		No recommendation	EN29-30	
Exterior sun control (S, E, W only)		No recommendation	EN24, 28, 30, 36, 40, 42 DL5-6	
Skylights	Maximum percent of roof area	3%	DL5-7, DL8, DL13	
	Thermal transmittance	U-0.69	DL7, DL8, DL13	
	Solar heat gain coefficient (SHGC)	0.64	DL8, DL13	
Lighting	Interior Lighting	Lighting power density (LPD)	0.9 W/ft <sup>2</sup>	EL1-2, 4, 8, 10-16
		Light source (linear fluorescent)	90 mean lumens/watt	EL4, 9, 17
		Ballast	Electronic ballast	EL4
		Dimming controls for daylight harvesting for WWR 25% or higher	Dim fixtures within 12 ft of N/S window wall or within 8 ft of skylight edge	DL1, 9-11, EL6-7
		Occupancy controls	Auto-off all unoccupied rooms	DL2, EL5, 6
		Interior room surface reflectances	80%+ on ceilings, 70%+ on walls and vertical partitions	DL3-4, EL3
HVAC	HVAC	Air conditioner (0-65 KBtuh)	13.0 SEER	HV1- 2, 4, 6, 12, 16-17, 20
		Air conditioner (>65-135 KBtuh)	No recommendation	HV1- 2, 4, 6, 12, 16-17, 20
		Air conditioner (>135-240 KBtuh)	No recommendation	HV1- 2, 4, 6, 12, 16-17, 20
		Air conditioner (>240 KBtuh)	No recommendation	HV1- 2, 4, 6, 12, 16-17, 20
		Gas furnace (0-225 KBtuh - SP)	80% AFUE or E <sub>t</sub>	HV1- 2, 6, 16, 20
		Gas furnace (0-225 KBtuh - Split)	90% AFUE or E <sub>t</sub>	HV1- 2, 6, 16, 20
		Gas furnace (>225 KBtuh)	80% E <sub>c</sub>	HV1- 2, 6, 16, 20
		Heat pump (0-65 KBtuh)	13.0 SEER/7.7 HSPF	HV1- 2, 4, 6, 12, 16-17, 20
		Heat pump (>65-135 KBtuh)	No recommendation	HV1- 2, 4, 6, 12, 16-17, 20
		Heat pump (>135 KBtuh)	No recommendation	HV1- 2, 4, 6, 12, 16-17, 20
	Economizer	Air conditioners & heat pumps - SP	No recommendation	HV23
	Ventilation	Outdoor air damper	Motorized control	HV7-8
		Demand control	CO <sub>2</sub> sensors	HV7, 22
	Ducts	Friction rate	0.08 in. w.c./100 feet	HV9, 18
Sealing		Seal class B	HV11	
Location		Interior only	HV9	
Insulation level		R-6	HV10	
SWH	SWH	Gas storage	90% E <sub>t</sub>	WH1-4
		Gas instantaneous	0.81 EF or 81% E <sub>t</sub>	WH1-4
		Electric storage 12 kW	EF > 0.99 – 0.0012xVolume	WH1-4
		Pipe insulation (d<1½ in./ d≥1½ in.)	1 in./ 1½ in.	WH6

**Note:** If the table contains “No recommendation” for a component, the user must meet the more stringent of either Standard 90.1 or the local code requirements in order to reach the 30% savings target.



Photographs courtesy of John Gregor, Cold Snap Photography

**Figure 3-24.** The Hartley Nature Center's placement is sensitive to the site and its natural features.

## Zone 7—Hartley Nature Center

DULUTH, MINN.

The Hartley Nature Center provides environmental education and outdoor recreation programs to adults and children. A major objective of the design team for the Hartley Nature Center was to create a new center that supports the learning process. Yet, condensation of warm interior air on cold surfaces within building envelopes in Zone 7 is a concern in design and construction. This building's many sustainable features, however, include extensive daylighting and ventilation; renewable, efficient energy systems for heating and cooling; and materials with recycled content.

The center was built on a south-facing slope to provide the building with exposure to sunlight. This access to sunlight enables the center to have passive solar features, natural lighting, ground-source heat pumps, and solar walls. There are solar panels mounted on the roof, capable of producing 11.8 kilowatts of electrical power. The system is connected to Minnesota Power's grid; Minnesota Power buys any excess electricity generated.

In addition to using renewable energy, the Hartley Nature Center uses energy-conserving methods to decrease the building's total energy use. The building has insulated

---

This example building demonstrates good design and construction practices suitable for this particular climate zone. In some cases, the example building may have incorporated additional features that go beyond the scope of the recommendations of this Guide.



**Figure 3-25.** The center features such sustainable and environmentally preferable building materials as 100 percent recycled content roof shingles, recycled content ceiling tiles, and FSC-certified wood.



**Figure 3-26.** The Hartley Nature Center was built on a south-facing slope, which has provided the center great exposure to sunlight.

concrete forms, heat recovery ventilation, and energy system sensors that track energy use as well as energy produced by the solar panels.

The nature center also used sustainable and environmentally preferable building materials, such as 100 percent recycled content roof shingles, recycled content ceiling tiles, Forest Steward Council certified wood, recycled content carpet tiles, natural-based wood glaze, and non-PVC materials. The center also constructed a pervious paving system on the walkways to minimize stormwater runoff.



# Zone 8

## Alaska

- Bethel (CA)
- Dillingham (CA)
- Fairbanks North Star
- Nome (CA)
- North Slope
- Northwest Arctic
- Southeast Fairbanks (CA)
- Wade Hampton (CA)
- Yukon-Koyukuk (CA)

Climate Zone 8 Recommendation Table

	Item	Component	Recommendation	How-To's in Chapter 4
Envelope	Roof	Insulation entirely above deck	R-30 c.i.	EN2, 17, 20-21
		Metal building	R-19 + R-19	EN3, 17, 20-21
		Attic and other	R-60	EN4, 17-18, 20-21
		Single rafter	R-38 + R-10 c.i.	EN5, 17, 20-21
		Surface reflectance/emittance	No recommendation	
	Walls	Mass (HC > 7 Btu/ft <sup>2</sup> )	R-15.2 c.i.	EN6, 17, 20-21
		Metal building	R-13 + R-16	EN7, 17, 20-21
		Steel framed	R-13 + R-21.6 c.i.	EN8, 17, 20-21
		Wood framed and other	R-13 + R-10 c.i.	EN9, 17, 20-21
		Below grade walls	R-15 c.i.	EN10, 17, 20-21
	Floors	Mass	R-16.7 c.i.	EN11, 17, 20-21
		Steel framed	R-38	EN12, 17, 20-21
		Wood framed and other	R-30	EN12, 17, 20-21
	Slabs	Unheated	R-20 for 24 in	EN13, 17, 19-21
		Heated	R-20 Full slab	EN14, 17, 19-21
	Doors	Swinging	U-0.50	EN15, 20-21
		Non-swinging	U-0.50	EN16, 20-21
	Vertical Glazing	Window to wall ratio (WWR)	20% to 40% maximum	EN23, 36-37
		Thermal transmittance	U-0.33	EN25, 31
		Solar heat gain coefficient (SHGC)	N, S, E, W N only No recommendation	
Window orientation		No recommendation	EN29-30	
Exterior sun control (S, E, W only)		No recommendation	EN24, 28, 30, 36, 40, 42 DL5-6	
Skylights	Maximum percent of roof area	3%	DL5-7, DL8, DL13	
	Thermal transmittance	U-0.58	DL7, DL8, DL13	
	Solar heat gain coefficient (SHGC)	No recommendation	DL8, DL13	
Lighting	Interior Lighting	Lighting power density (LPD)	0.9 W/ft <sup>2</sup>	EL1-2, 4, 8, 10-16
		Light source (linear fluorescent)	90 mean lumens/watt	EL4, 9, 17
		Ballast	Electronic ballast	EL4
		Dimming controls for daylight harvesting for WWR 25% or higher	Dim fixtures within 12 ft of N/S window wall or within 8 ft of skylight edge	DL1, 9-11, EL6-7
		Occupancy controls	Auto-off all unoccupied rooms	DL2, EL5, 6
		Interior room surface reflectances	80%+ on ceilings, 70%+ on walls and vertical partitions	DL3-4, EL3
HVAC	HVAC	Air conditioner (0-65 KBtuh)	13.0 SEER	HV1- 2, 4, 6, 12, 16-17, 20
		Air conditioner (>65-135 KBtuh)	No recommendation	HV1- 2, 4, 6, 12, 16-17, 20
		Air conditioner (>135-240 KBtuh)	No recommendation	HV1- 2, 4, 6, 12, 16-17, 20
		Air conditioner (>240 KBtuh)	No recommendation	HV1- 2, 4, 6, 12, 16-17, 20
		Gas furnace (0-225 KBtuh - SP)	80% AFUE or E <sub>t</sub>	HV1- 2, 6, 16, 20
		Gas furnace (0-225 KBtuh - Split)	90% AFUE or E <sub>t</sub>	HV1- 2, 6, 16, 20
		Gas furnace (>225 KBtuh)	80% E <sub>c</sub>	HV1- 2, 6, 16, 20
		Heat pump (0-65 KBtuh)	13.0 SEER/7.7 HSPF	HV1- 2, 4, 6, 12, 16-17, 20
		Heat pump (>65-135 KBtuh)	No recommendation	HV1- 2, 4, 6, 12, 16-17, 20
	Heat pump (>135 KBtuh)	No recommendation	HV1- 2, 4, 6, 12, 16-17, 20	
	Economizer	Air conditioners & heat pumps - SP	No recommendation	HV23
	Ventilation	Outdoor air damper	Motorized control	HV7-8
		Demand control	CO <sub>2</sub> sensors	HV7, 22
Ducts	Friction rate	0.08 in. w.c./100 feet	HV9, 18	
	Sealing	Seal class B	HV11	
	Location	Interior only	HV9	
	Insulation level	R-8	HV10	
SWH	SWH	Gas storage	90% E <sub>t</sub>	WH1-4
		Gas instantaneous	0.81 EF or 81% E <sub>t</sub>	WH1-4
		Electric storage 12 kW	EF > 0.99 – 0.0012xVolume	WH1-4
		Pipe insulation (d<1½ in./d≥1½ in.)	1 in./ 1½ in.	WH6

Note: If the table contains “No recommendation” for a component, the user must meet the more stringent of either Standard 90.1 or the local code requirements in order to reach the 30% savings target.



Photographs courtesy of Chris Arend

**Figure 3-27.** The design of the YKHC Community Health Services Building imparts a feeling of well-being and respect to the local clientele.

## Zone 8—Yukon Kuskokwim Health Corporation, Community Health Services Building

BETHEL, ALASKA

The Yukon Kuskokwim Health Corporation (YKHC), a Yup'ik Eskimo nonprofit health corporation, serves 47 villages in southwestern Alaska. The YKHC required a building to consolidate several existing facilities and to provide economy of ownership. The designers, Livingston Slone Inc., helped the YKHC achieve its goals. Not only does the Community Health Services Building incorporate several sustainable design features, it provides a strong sense of cultural identity that imparts a feeling of well-being and respect to the local native clientele.

Zone 8 receives an average of more than 50 inches of snow each year and is characterized by high winds and temperatures as low as  $-40^{\circ}$  F in the winter. Thus, the Community Health Services Building is heated by fuel-oil-fired boilers. Diesel-electric generators provide all power needs for the community. Because there is no road access,

---

This example building demonstrates good design and construction practices suitable for this particular climate zone. In some cases, the example building may have incorporated additional features that go beyond the scope of the recommendations of this Guide.





**Figure 3-28.** Familiar Yup'ik design motifs, such as basket weaving, spirit masks, and animistic themes, are used throughout the center.



**Figure 3-29.** Traditional hues of beach grasses, indigenous clays, rich driftwoods (resembling oiled walnut), wild berries, and charcoal are immediately apparent and familiar throughout the center.

all fuel oil for heat and power is brought in by barge from Seattle in the summer and stored in fuel farms. As a result, fuel prices are astronomical, so energy efficiency was of paramount importance.

The building's placement on the site considers the prevailing wind direction. The placement protects the entry from blowing snow and accommodates "wind scour" that keeps snow from building up at entrances and under the building. The building is set on steel piling driven deep into the permanently frozen soil (permafrost). To prevent thawing of the permafrost and subsequent foundation failure, the building is completely isolated from the soil by an open air space of four feet or more. Although this feature compounds envelope heat loss by adding another surface to the envelope, the building is, however, energy efficient with R-values ranging from R-30 for the walls and under-floor to R-50 for the roof.

The airtight envelope is a structural insulated panel system of foam-core wood sandwich panels. Special detailing of the panels minimizes thermal bridging and supports a continuous vapor retarder. To preserve the vapor retarder while housing the building's heating, power, and communications distribution systems, an interior utility chase is provided within the exterior walls.

The exterior vestibule (arctic entry) was designed to create a temperature buffer between the indoors and outdoors. The separation creates an air chamber that reduces heat loss when the doors are open.

Motion-sensor lighting controls and high-efficiency lighting fixtures contribute to energy savings. To reduce power consumption, lighter hues of color were used to make each lumen "go farther" and interior materials and finishes were chosen for high light reflectance properties. Triple-glazed, low-E vinyl-framed windows were placed in strategic locations to provide views and daylighting where possible.



# How to Implement Recommendations

# 4

Recommendations are contained in the individual Tables in chapter 3, “Recommendations by Climate.” The following how-to tips are intended to provide guidance on good practices for implementing the recommendations as well as cautions to avoid known problems in energy-efficient construction.

## **QUALITY ASSURANCE**

---

Quality and performance are never an accident. It is always the result of high intention, sincere effort, intelligent direction, and skilled execution. A high quality building that functions in accordance with its design intent, and thus meets the performance goals established for it, requires that quality assurance be an integral part of the design and construction process. This process is typically referred to as commissioning.

Commissioning requires a dedicated person, with no other project responsibilities, who can execute a systematic process that verifies that the systems and assemblies perform as required. An independent party, whether it be a third party commissioning professional or a capable member of the organization of the installing contractor, architect, or engineer of record, is needed to ensure that the strategy sets and recommendations contained in this Guide meet the owner’s stated requirements.

The commissioning process is applicable to all buildings. However, large and complex buildings require a correspondingly greater level of effort than is required for small, simple buildings. Small office buildings covered by this Guide have simple systems and generally do not require the level of commissioning required for more complex buildings. The following commissioning practice recommendations meet this objective.

Activity	Complete
Owner selects QA provider and commitment to QA to designers and, through the contract documents, to contractors	
QA provider reviews the owner's project requirements and the designers' basis-of-design documentation for completeness and clarity and identifies area requiring further clarification	
QA provider conducts focused review of 100% construction documents that verifies designers integrated owner's project requirements and identifies performance concerns to owner and designers in written format	
QA provider reviews comments from design review with designers and owner and adjudicates issues	
QA provider develops commissioning specifications that defines team roles and responsibilities and pass/fail criteria for performance verification	
QA provider assists design team by providing overview of process to prospective bidders and answers questions at pre-bid meeting	
QA provider prepares prefunctional checklists and commissioning plan and conducts meeting with project team and establishes tentative schedule for commissioning activities	
QA provider reviews submittal information for systems being commissioned and develops functional test procedures contractors will use to demonstrate commissioned system performance	
QA provider conducts two site visits during construction to verify concerns identified during 100% construction document review were corrected and to identify issues that would affect performance	
QA provider schedules testing through general contractor and directs, witnesses, and documents the functional testing that demonstrates performance	
QA provider reviews operation and maintenance information and verifies that owner is trained in warranty and preventive maintenance requirements and has operational and maintenance information needed to meet the requirements	

## Good Design Practice

### QA1

#### *Select Team*

Selection of the correct team members is critical to the success of a project. Owners who understand the connection between a building's performance and the impact on the environment, psychological and physiological perceptions of occupants, and the total cost of ownership, also understand the importance of team dynamics in selection of the team members responsible for delivering their project. Owners should evaluate qualifications of candidates, past performance, cost of services, and availability of the candidates in making a selection.

### QA2 *Selection of Quality Assurance Provider*

**Quality assurance** is a systematic process of verifying the owner's project requirements, operational needs, and basis of design and ensuring that the building performs in accordance with these defined needs. The selection of a provider should include the same evaluation process the owner would use to select other team members. Qualifications in providing quality assurance services, past performance of projects, cost of services, and availability of the candidate are some of the parameters an owner should investigate and consider in making a selection.

Owners may select a member of the design or construction team as the QA provider. While there are exceptions in general, most designers are not comfortable operating and testing assemblies and equipment and most contractors do not have the technical background necessary to evaluate performance. Commissioning (Cx) requires in-depth technical knowledge of the building envelope, mechanical, electrical, and plumbing systems and operational and construction experience. This function is best performed by a third party entity responsible to the owner because political issues often prevent a member of the design or construction organizations from fulfilling this responsibility.

### QA3 *Owner's Project Requirements*

**Owner's project requirements** (OPR) is a written document that details the functional requirements of a project and the expectations of how the facility will be used and operated. This includes strategies and recommendations selected from this Guide (see Table 2-1 and chapters 3 and 4) that will be incorporated into the project, anticipated hours of operation provided by the owner, and basis of design assumption made. The OPR forms the foundation of the team's tasks by defining project and design goals, measurable performance criteria, owner directives, budgets, schedules, and supporting information into a single concise document. The quality assurance process depends on a clear, concise, and comprehensive owner's project requirements document.

Development of the OPR document requires input from all key facility users and operators and evolves through each project phase. Documenting decisions made during the design, construction, and occupancy and operations phases, it is the primary tool for benchmarking success and quality at all phases of the project delivery and throughout the life of the facility. Included in the OPR are the designers' assumptions, which form the basis of design. The basis of design records the concepts, calculations, decisions, and product selections used to meet the OPR and to satisfy applicable regulatory requirements, standards, and guidelines.

**Note:** The owner's project requirements (OPR) remains relatively fixed from its initial development until directed otherwise by the owner.

### QA4 *Budgets Contained in OPR*

The OPR is used to define the team's scope in both broad and specific terms. It also defines the quality assurance scope and budgets. Effort and cost associated with designing and constructing an energy-efficient building can and often are lost because the performance of systems is not verified.

### QA5 *Design and Construction Schedule*

The inclusion of QA activities in the construction schedule is a critical part of delivering a successful project. Identify the activity and time required for design review and performance verification activities to minimize time and effort needed to accomplish activities and correct deficiencies.

**QA6**      *Design Review*

A second pair of eyes provided by the QA provider gives a fresh perspective that allows identification of issues and opportunities to improve quality of the construction documents, and verification that the owner's project requirements are being met. Issues identified can easily be corrected before effort and materials are expended, providing potential savings in construction costs and reducing risk to the team. (See "Suggested Quality Assurance Scope" for more detail).

**QA7**      *Defining Quality Assurance at Pre-Bid*

The building industry has traditionally delivered buildings without using a verification process. Changes in traditional design and construction procedures and practices require education of the construction team that explains how the QA process change will affect the various trades bidding the project. It is extremely important that the QA process be reviewed with the bidding contractors to facilitate understanding of and help minimize fear associated with new practices. Teams who have participated in the commissioning process typically appreciate the process because they are able to resolve problems while their manpower and materials are still on the project, significantly reducing callbacks and associated costs while enhancing their delivery capacity.

**QA8**      *Verifying Building Envelope Construction*

The building envelope is a key element of an energy-efficient design. Compromises in assembly performance are common and are caused by a variety of factors that can easily be avoided. Improper placement of insulation, improper sealing or lack of sealing air barriers, wrong or poorly performing glazing and fenestration systems, incorrect placement of shading devices, misplacement of daylighting shelves, and misinterpretation of assembly details can significantly compromise the energy performance of the building (see "Cautions" in this section). The perceived value of the commissioning process is that it is an extension of the quality control processes of the designer and contractor as the team works together to produce quality energy efficient projects.

**QA9**      *Verifying Electrical and HVAC Systems Construction*

Performance of electrical and HVAC systems are key elements of this Guide. How systems are installed affect how efficiently they can be serviced and how well they will perform. Observations during construction identify problems when they are easy to correct.

**QA10**      *Performance Testing*

Performance testing of systems is essential to ensuring that a project following this guideline will actually attain the energy savings that can be expected from the strategies and recommendations contained in this Guide (see "Suggested Commissioning Scope" for quality assurance provider responsibilities). If the contractors utilize the checklists as intended, functional testing of systems will occur quickly and only minor but important issues will need to be resolved to ensure that the building will perform as intended. Owners with operational and maintenance personnel can use the functional testing process as a training tool to educate their staff on how the systems operate as well as for system orientation prior to training.

**QA11**      ***Substantial Completion***

“Substantial completion” is generally associated with completion and acceptance of the life safety systems. Contractors, generally, have not completed the systems sufficiently at substantial completion to verify their performance. While the systems may be operational, they probably are not yet operating as intended. Expected performance can only be accomplished when all systems operate interactively to provide the desired results. As contractors finish their scope of work, they will identify and resolve many but not all performance problems. The quality assurance provider helps to resolve remaining issues through interaction with the team.

**QA12**      ***Maintenance Manual Submitted and Accepted***

Communication of activities the owner will be responsible for completing in order to maintain the manufacturers’ warranties is part of the QA/Cx process (see “Suggested Commissioning Scope” for quality assurance provider responsibilities). A copy of the OPR should be included to provide the operation and maintenance (O & M) staff an understanding of how the building is intended to operate.

**QA13**      ***Resolve Quality Control Issues Identified Throughout the Construction Phase***

Issues identified during the construction process are documented into an Issues Log and presented to the team for collaborative resolution. Issues are tracked and reviewed at progress meetings until the issues are resolved. Completion and acceptance of the systems and assemblies by the owner will be contingent upon what issues are still outstanding at the end of the project. Minor issues may be tracked by the owner’s O & M staff, while other issues will require resolution before acceptance of the work. The completion of the QA/Cx process is verification that the issues identified have been resolved.

**QA14**      ***Final Acceptance***

Final acceptance generally occurs after the QA/Cx issues in the log have been resolved except for minor issues the owner is comfortable with resolving in the warranty period.

**QA15**      ***Establish Building Maintenance Program***

Continued performance and control of operational and maintenance costs require a maintenance program. The operation and maintenance manuals provide information that the O & M staff use to develop this program. The level of expertise typically associated with O & M staff for buildings covered by this Guide is generally much lower than that of a degreed or accredited engineer, and they typically need assistance with development of a preventive maintenance program. The QA/Cx provider can help bridge the knowledge gaps of the O & M staff and assist the owner with developing a program that would help ensure continued performance. The benefits associated with energy-efficient buildings are realized when systems perform as intended through proper design, construction, operation, and maintenance.

**QA16**      ***Monitor Post-Occupancy Performance***

Establishing measurement and verification procedures with a benchmark of performance based on actual building performance after it has been commissioned can identify when corrective action and/or repair are required to maintain energy performance. Utility consumption and factors affecting utility consumption should

be monitored and recorded to establish the building performance during the first year of operation.

Variations in utility usage can be justified based on changes in conditions typically affecting energy use, such as weather, occupancy, operational schedule, maintenance procedures, and equipment operations required by these conditions. While most buildings covered in this Guide will not use a formal measurement and verification process, tracking the specific parameters listed above does allow the owner to quickly review utility bills and changes in conditions. Poor performance is generally obvious to the reviewer when comparing the various parameters. QA/Cx providers can typically help owners understand when operational tolerances are exceeded and can provide assistance in defining what actions may be required to return the building to peak performance.

### Suggested Commissioning Scope

- Review the owner's project requirements and the designers' basis-of-design documentation for completeness and clarity. The information provided by the design team for review should include project and design goals, measurable performance criteria, budgets, schedules, success criteria, and supporting information.
- Develop project-specific quality assurance/commissioning specifications for building envelope, electrical, mechanical, and plumbing systems that will be verified during the delivery of the project. The specifications will incorporate QA/Cx activities into the construction process and provide a clear understanding to all participants of their specific roles, responsibilities, and effort. The Guide specifications will be reviewed, modified, and blended into the construction documents (CDs) by the designers.
- Conduct one design review of the 100% complete construction documents. The review will focus on ensuring the design is consistent with the owner's project requirements and the designers' basis of design, and that all construction requirements are clear and well coordinated. It is also intended to ensure that the specifications describe the roles and responsibilities of all parties to the commissioning process so that contractors have a clear understanding of their responsibilities. Prepare a report identifying concerns and opportunities, and use it in working with the owner and designers to develop a collaborative partnership that will ensure delivery of a high quality building that performs as intended. Provide a report that tracks issues to resolution and facilitate a collaborative process to facilitate resolution.
- Conduct one two-hour meeting to discuss review comments and adjudicate issues with the design team and issue a final report illustrating the disposition of each issue raised. Use the report to verify during construction site visits that issues were corrected.
- If a pre-bid meeting is held with bidding contractors, participate in it to emphasize the inclusion of commissioning and describe the commissioning process for the specific project.
- Prepare prefunctional checklists and the QA/Cx plan and conduct a one-hour meeting with the project team reviewing QA procedures, roles, and responsibilities and establishing a tentative schedule of QA/Cx activities. During the meeting provide the prefunctional checklists to the contractors for their use during the delivery process.
- Review submittal information for systems being commissioned and provide appropriate comments to team. Based on the submittal information, develop functional test procedures that will be used to verify system performance and distribute to the team.
- Conduct two site visits during construction to observe construction techniques and to identify issues that may affect performance. Review issues with appropriate team members at end of site visit in accordance with established communication protocols and issue one report per visit documenting findings. Establish and maintain an issues log for tracking issues identified.



- Direct and witness functional testing and document results. Issues identified will be documented in the issues log and tracked to resolution. General contractor will schedule functional testing activities and ensure that responsible parties needed for verification are present.
- Review operation and maintenance information to ensure warranty requirements and preventive maintenance information required are part of the documentation along with a copy of the owner's project requirements and basis-of-design information.
- Witness training of O&M staff to help ensure O&M staff understand systems and their operation, warranty responsibilities, and preventive maintenance requirements.

## ENVELOPE

---

### Opaque Envelope Components

Note that the following how-to's address the recommendations in chapter 3, but they are not necessarily applicable to any specific construction project.

#### Good Design Practice

##### ENI

##### *Cool Roofs (Climate Zones: ① ② ③)*

Cool roofs are recommended for roofs with insulation entirely above deck and metal building roofs. In order to be considered a cool roof for climate zones 1-3 the following conditions apply:

1. *The roof has a high reflectance.* The high reflectance keeps much of the sun's energy from being absorbed.
2. *The roof has a high thermal emittance.* The high emittance radiates away any solar energy that is absorbed, allowing the roof to cool more rapidly.

The radiative property values should be rated by a laboratory accredited by the Cool Roof Rating Council.

Cool roofs are typically white and have a smooth texture. Commercial roofing products that qualify as cool roofs fall in two categories: single-ply and liquid-applied. Examples of single-ply products include:

- White PVC (polyvinyl chloride)
- White CPE (chlorinated polyethylene)
- White CPSE (chlorosulfonated polyethylene, e.g., Hypalon)
- White TPO (thermoplastic polyolefin)

Liquid-applied products may be used to coat a variety of substrates. Products include:

- White elastomeric, polyurethane, or acrylic coatings
- White paint (on metal or concrete)

**EN2** *Roofs, Insulation Entirely above Deck (Climate Zones: all)*

The insulation entirely above deck should be continuous insulation (c.i.) rigid boards because there are no framing members present that would introduce thermal bridges or short circuits to bypass the insulation.

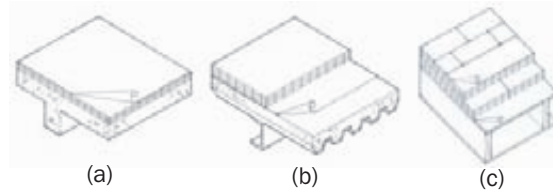

**Figure 4-1.** (EN2) Insulation entirely above deck. Insulation is installed above a (a) concrete, (b) wood, or (c) metal deck in a continuous manner.

When two layers of continuous insulation are used in this construction, the board edges should be staggered to reduce the potential for convection losses or thermal bridging. If an inverted or protected membrane roof system is used, at least one layer of insulation is placed above the membrane while a maximum of one layer is placed beneath the membrane.

**EN3** *Roofs, Metal Buildings (Climate Zones: all)*

Metal buildings pose particular challenges in the pursuit of designing and constructing advanced buildings. The metal skin and purlin/girt connection, even with compressed fiberglass between them, is highly conductive, which limits the effectiveness of the insulation. A purlin is a horizontal structural member that supports the roof covering. In metal building construction, this is typically a z-shaped cold-formed steel member; but a steel bar joist can be used for longer spans.

The thermal performance of metal building roofs with fiberglass batts is improved by treating the thermal bridging associated with fasteners. Use of foam blocks is a proven technique to reduce the thermal bridging. Thermal blocks, with minimum dimensions of 1 inch by 3 inches, should be R-5 rigid insulation installed parallel to the purlins.

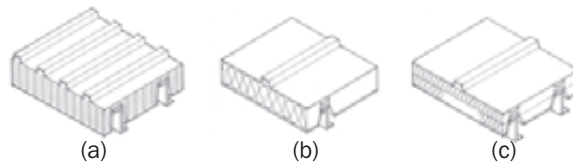

**Figure 4-2.** (EN3) Pre-fabricated metal roofs showing thermal blocking of purlins.

Thermal blocks can be used successfully with standing seam roofs that utilize (a) concealed clips of varying heights to accommodate the block. However, a thermal block cannot be used with a through-fastened roof that is screwed directly to the purlins because it

diminishes the structural load carrying capacity by “softening” the connection and restraint provided to the purlin by the roof.

In climate zones 1 and 2, the recommended construction is (b) R-19 insulation batts draped perpendicularly over the purlins. Thermal blocks are then placed above the purlin/batt, and the roof deck is secured to the purlins.

In climate zones 3 through 8 the recommended construction is (c) two layers of batt insulation. The first insulation batt is draped perpendicularly over the purlins with enough looseness to allow the second insulation batt to be laid above it, parallel to the purlins. In the metal building industry, this is known as the “sag and bag” insulation system.

Continuous rigid insulation can be added to provide additional insulation if required to meet the U-factors listed in Appendix A.

**EN4** *Roofs, Attics and Other Roofs (Climate Zones: all)*

Attics and other roofs include roofs with insulation entirely below (inside of) the roof structure (i.e., attics and cathedral ceilings) and roofs with insulation both above and below the roof structure. Ventilated attic spaces need to (a) have the insulation installed at the ceiling line. Unventilated attic spaces may have the insulation installed at the roof line. When suspended ceilings with removable ceiling tiles are used, (b) the insulation performance is best when installed at the roof line.

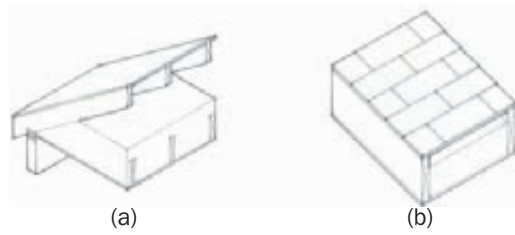

**Figure 4-3.** (EN4) Attic and other roofs.

**EN5** *Roofs, Single Rafter (Climate Zones: all)*

Single rafter roofs have the roof above and ceiling below both attached to the same wood rafter, and the insulation is located in the cavity created between the wood rafters. Single rafters can be constructed using solid wood framing members or truss type framing members. The insulation should be installed between the wood rafters and in intimate contact with the ceiling to avoid the potential thermal short-circuiting associated with open or exposed air spaces.

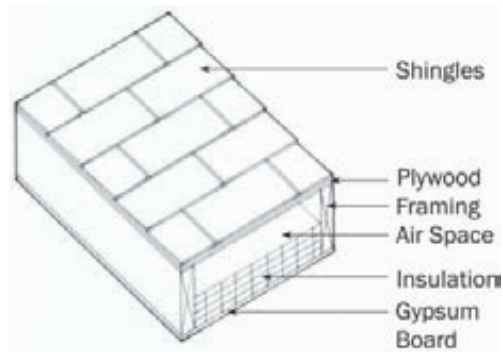

**Figure 4-4.** (EN5) Wood joists, single rafter.

**EN6** *Walls, Mass (Climate Zones: all)*

Mass walls are defined as those with a heat capacity exceeding 7 Btu/ft<sup>2</sup>·°F. Insulation may be placed either on the inside or the outside of the masonry wall. When insulation is placed on the exterior of the wall, (a) rigid continuous insulation (c.i.) is recommended. When insulation is placed (b) on the interior of the wall, a furring or framing system should be used, provided the total wall assembly has a U-factor that is less than or equal to the appropriate climate zone construction listed in Appendix A.

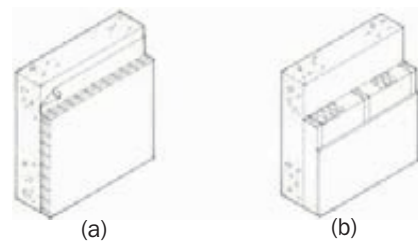

**Figure 4-5.** (EN6) Walls, mass. Any concrete or masonry wall with a heat capacity exceeding 7 Btu/ft<sup>2</sup>·°F.

The greatest advantages of mass can be obtained when insulation is placed on the exterior of the mass. In this case, the mass absorbs internal heat gains that are later released in the evenings when the buildings are not occupied.

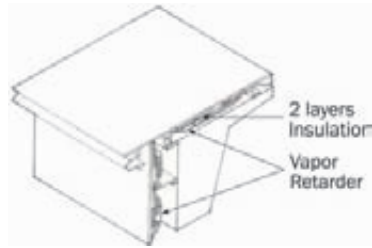
**EN7 Walls, Metal Building (Climate Zones: all)**

**Figure 4-6.** (EN7) Walls, metal building.

In climate zones 1-4, a single layer of fiberglass batt insulation is recommended. The insulation is installed continuously perpendicular to the exterior of the girts and is compressed as the metal skin is attached to the girts. In climate zones 5-8, two layers of fiberglass batt insulation are recommended. The first layer is installed continuously perpendicular to the exterior of the girts and is compressed as the metal skin is attached to the girts. The second layer of insulation is

installed parallel to the girts within the framing cavity.

In all climate zones, rigid continuous insulation (c.i.) is another option provided the total wall assembly has a U-factor that is less than or equal to the appropriate climate zone construction listed in Appendix A.

**EN8 Walls, Steel Framed (Climate Zones: all)**

Cold-formed steel framing members are thermal bridges to the cavity insulation. Adding exterior foam sheathing as continuous insulation (c.i.) is the preferred method to upgrade the wall thermal performance because it will increase the overall wall thermal performance and tends to minimize the impact of the thermal bridging. Cavity insulation should be used within the steel-framed wall, while rigid continuous insulation should be placed on the exterior side of the steel framing. Alternative combinations of cavity insulation and sheathing in thicker steel-framed walls can be used provided that the proposed total wall assembly has a U-factor that is less than or equal to the U-factor for the appropriate climate zone construction listed in Appendix A.

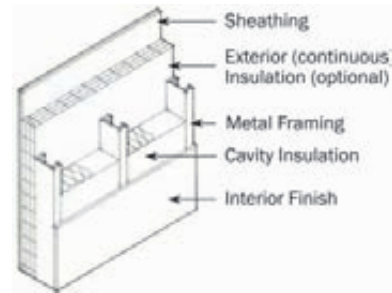

**Figure 4-7.** (EN8) Walls, steel framed. A common construction type in nonresidential buildings.

**EN9 Walls, Wood Frame and Other (Climate Zones: all)**

Cavity insulation is used within the wood-framed wall, while rigid continuous insulation (c.i.) is placed on the exterior side of the framing. Alternative combinations of cavity insulations and sheathings in thicker walls can be used provided the total wall assembly has a U-factor that is less than or equal to the appropriate climate zone construction listed in Appendix A.

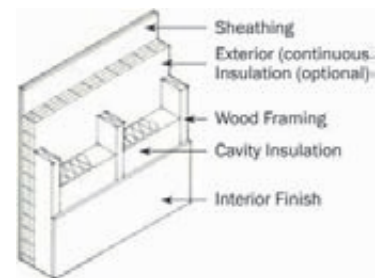

**Figure 4-8.** (EN9) Walls, wood frame and other.

**EN10 Below-Grade Walls (Climate Zones: all)**

Insulation, when recommended, may be placed either on the inside or the outside of the below-grade wall. If placed on the exterior of the wall, (a) rigid continuous insulation (c.i.) is recommended. If placed on the interior, (b) a furring or (c) framing system is recommended provided the total wall assembly has a C-factor that is less than or equal to the appropriate climate zone construction listed in Appendix A.

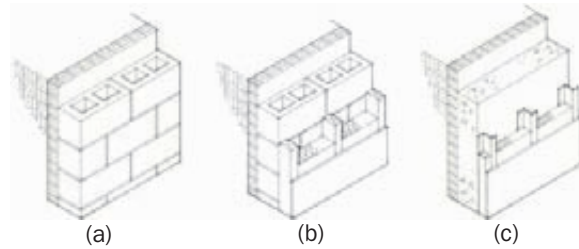

**Figure 4-9.** (EN10) Below grade walls—outer surface of the wall is in contact with the earth, and the inside surface is adjacent to conditioned or semi-heated space.

**EN11 Floors, Mass (Climate Zones: all)**

Insulation should be continuous and either integral to or above the slab. This can be achieved by (a) placing high-density extruded polystyrene as continuous insulation (c.i.) above the slab with either plywood or a thin layer of concrete on top. Placing insulation below the deck is not recommended, due to losses through any concrete support columns or through the slab perimeter.

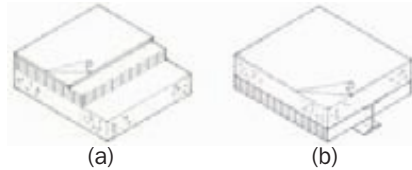

**Figure 4-10.** (EN11) Floors, mass. Any floor with a heat capacity exceeding 7 Btu/ft<sup>2</sup>·°F.

**Exception:** Buildings or zones within buildings that have durable floors for heavy machinery or equipment could (b) place insulation below the deck.

When heated slabs are placed below grade, below-grade walls should meet the insulation recommendations for perimeter insulation according to the heated slab-on-grade construction.

**EN12 Floors, Steel Joist or Wood Frame (Climate Zones: all)**

Insulation should be installed parallel to the framing members and in intimate contact with the flooring system supported by the framing member in order to avoid the potential thermal short circuiting associated with open or exposed air spaces. Nonrigid insulation should be supported from below no less frequently than 24 in. on center.



**Figure 4-11.** (EN12) Floors, wood frame.

**EN13 Slab-on-Grade Floors, Unheated (Climate Zones: 6 7 8)**

(a) Continuous rigid insulation should be used around the perimeter of the slab and should reach the depth listed in the recommendation or to the bottom of the footing, whichever is deeper. (b) Additionally, in climate zones 7 and 8 and in cases where the frost line is deeper than the footing, continuous insulation should be placed beneath the slab as well.

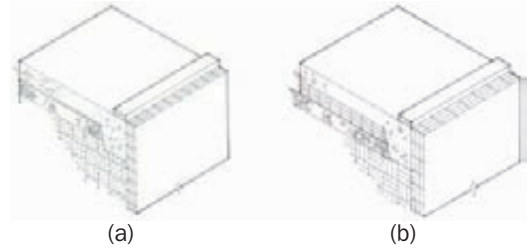

**Figure 4-12.** (EN13) Slab-on-grade floors, unheated. No heating elements either within or below the slab.

**EN14 Slab-on-Grade Floors, Heated (Climate Zones: 4 5 6 7 8)**

Continuous rigid insulation should be used around the perimeter of the slab and should reach to the depth listed or to the frost line, whichever is deeper. Additionally, in climate zones 7 and 8, continuous insulation should be placed below the slab as well.

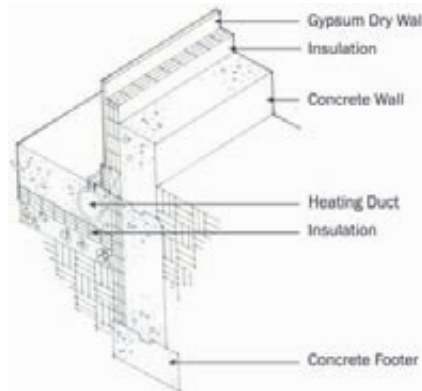

**Note:** In areas where termites are a concern and rigid insulation is not recommended for use under the slab, a different heating system should be used.

**Figure 4-13.** (EN14) Slab-on-grade floors, heated. Heating elements either within (as shown) or below the slab.

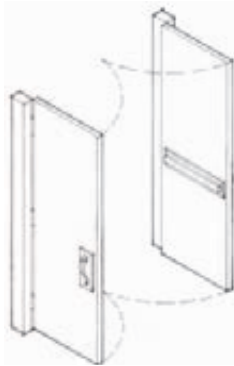
**EN15 Doors, Swinging (Climate Zones: all)**

A U-factor of 0.37 corresponds to an insulated double-panel metal door. A U-factor of 0.61 corresponds to a double-panel metal door.

**Figure 4-14.** (EN15) Doors, swinging. Opaque doors with hinges on one side and revolving doors.

**EN16 Doors, Roll-up or Sliding (Climate Zones: all)**

Roll-up or sliding doors are recommended to have R-4.75 rigid insulation or meet the recommended U-factor. When meeting the recommended U-factor, the thermal bridging at the door and section edges is to be included in the analysis.

## Options

### EN17 *Alternative Constructions (Climate Zones: all)*

The climate zone recommendations provide only one solution for upgrading the thermal performance of the envelope. Other constructions can be equally effective, but they are not shown in this document. Any alternative construction that is less than or equal to the U-factor, C-factor, or F-factor for the appropriate climate zone construction is equally acceptable. A table of U-factors, C-factors, and F-factors that corresponds to all of the recommendations is presented in Appendix A. Procedures to calculate U-factors and C-factors are presented in the *ASHRAE Handbook—Fundamentals*, and expanded U-factor, C-factor, and F-factor tables are presented in Standard 90.1-1999, Appendix A.

## Cautions

The design of building envelopes for durability, indoor environmental quality, and energy conservation should not create conditions of accelerated deterioration, reduced thermal performance, or problems associated with moisture and air infiltration. The following **cautions** should be incorporated into the design and construction of the building.

### EN18 *Heel Heights (Climate Zones: all)*

When insulation levels are increased in attic spaces, the heel height should be raised to avoid or at least minimize the eave compression.

### EN19 *Slab Edge Insulation (Climate Zones: all)*

Use of slab edge insulation improves thermal performance, but problems can occur in regions of the country that have termites.

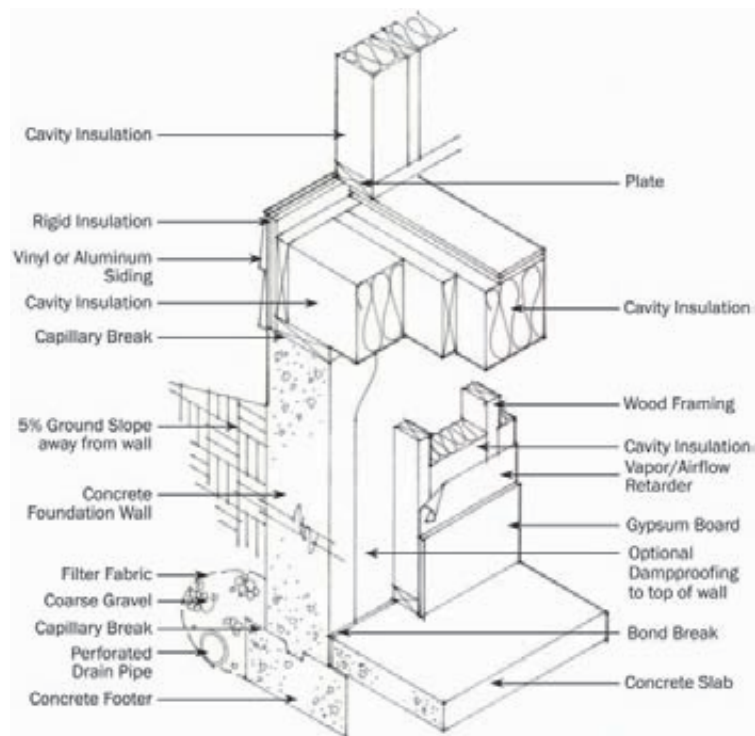

**Figure 4-15a.** (EN20) Moisture control for mixed climates.

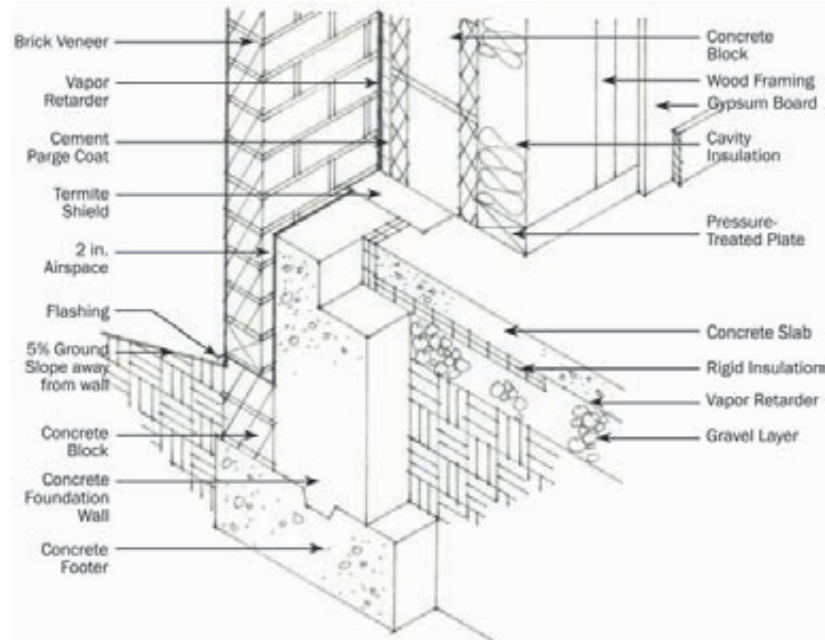

**Figure 4-15b.** (EN20) Moisture control for warm, humid climates.

**EN20** *Moisture Control (Climate Zones: all)*

Building envelope assemblies should be designed to prevent wetting, high moisture content, liquid water intrusion, and condensation caused by diffusion of water vapor.

**EN21** *Air Infiltration Control (Climate Zones: all)*

- The building envelope should be designed and constructed with a continuous air barrier system to control air leakage into or out of the conditioned space. An air barrier system should also be provided for interior separations between conditioned space and space designed to maintain temperature or humidity levels that differ from those in the conditioned space by more than 50% of the difference between the conditioned space and design ambient conditions. The air barrier system should have the following characteristics:
  - It should be continuous, with all joints made airtight.
  - Materials used should have an air permeability not to exceed  $0.004 \text{ cfm/ft}^2$  under a pressure differential of 0.3 in. water (1.57 psf) ( $0.02 \text{ L/s}\cdot\text{m}^2$  at 75 Pa) when tested in accordance with ASTM E 2178.
  - The system is capable of withstanding positive and negative combined design wind, fan, and stack pressures on the envelope without damage or displacement and should transfer the load to the structure. It should not displace adjacent materials under full load.
  - It is durable or maintainable.
- The air barrier material of an envelope assembly should be joined in an airtight and flexible manner to the air barrier material of adjacent assemblies, allowing for the relative movement of these assemblies and components due to thermal and moisture variations, creep, and structural deflection.



1. Connections should be made between:
  - (a) Foundation and walls.
  - (b) Walls and windows or doors.
  - (c) Different wall systems.
  - (d) Wall and roof.
  - (e) Wall and roof over unconditioned space.
  - (f) Walls, floor, and roof across construction, control, and expansion joints.
  - (g) Walls, floors, and roof to utility, pipe, and duct penetrations.

All penetrations of the air barrier system and paths of air infiltration/exfiltration should be made airtight.

## Vertical Glazing (Envelope)

### Good Design Practice

EN22

(Climate Zones: all)

The recommendations for vertical windows are listed in chapter 3 by climate zone. Table 4-1 below shows the type of window construction that generally corresponds to the U-factor specifications in the chapter 3 Recommendation Tables.

**Table 4-1. Vertical Fenestration Descriptions**

U-Factor	SHGC	VLT	Description
0.47	0.31	0.37	Metal frame with a thermal break Clear glass with medium performance reflective coating Insulated spacers between panes Low-e coated glass
0.44	0.46	0.62	Metal frame with a thermal break Clear glass Insulated spacers between panes Low-e coated glass
0.38	0.41	0.60	Vinyl frame Clear glass Insulated spacers between panes Low-e coated glass

To be useful and consistent, the U-factors for windows should be measured over the entire window assembly, not just the center of glass. Look for a label that denotes the window rating is certified by the National Fenestration Rating Council (NFRC). The selection of high-performance window products should be considered separately for each orientation of the building and for daylighting and viewing functions.

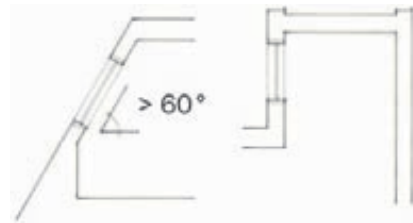

**Figure 4-16.** (EN22) Vertical fenestration.

**EN23 Window-Wall Ratio (WWR) (Climate Zones: all)**

The window-wall ratio is the percentage resulting from dividing the total glazed area of the building by the total wall area. For any given WWR selected between 20% and 40%, the recommended values for U-factor and SHGC contribute toward the 30% savings target of the entire building. A reduction in the overall WWR ratio will also save energy, especially if glazing is significantly reduced on the east and west façades. Reducing glazing on east and west facades for energy reduction should be done while maintaining consistency with the needs for view, daylighting, and passive solar strategies.

**Window Design Guidelines for Thermal Conditions**

Uncontrolled solar heat gain is a major cause of energy consumption for cooling in warmer climates and thermal discomfort for occupants. Appropriate configuration of windows according to the orientation of the wall on which they are placed can significantly reduce these problems.

**EN24 Solar Heat Gain Is Most Effectively Controlled on the Outside of the Building (Climate Zones: all)**

Significantly greater energy savings are realized when sun penetration is blocked before entering the windows. Horizontal overhangs located at the top of the windows are most effective for south-facing façades and must continue beyond the width of the windows to adequately shade them. The vertical extension of the overhang depends on the latitude and the climate (see Figure 4-17). Vertical fins oriented slightly north are most effective for east- and west-facing façades. Consider louvered or perforated sun control devices, especially in primarily overcast and colder climates, to prevent a totally dark appearance in those environments.

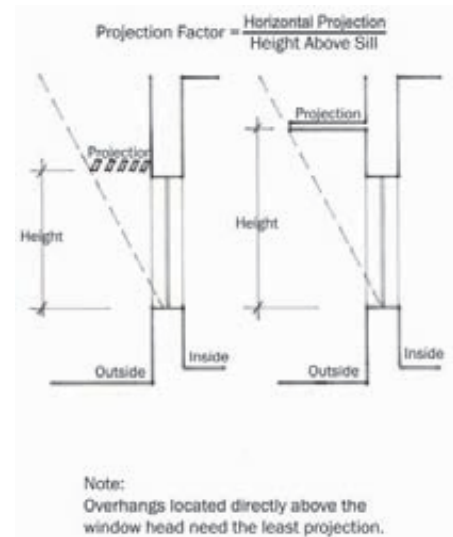

**Figure 4-17.** (EN24) Windows with overhang.

**EN25 Operable versus Fixed Windows (Climate Zones: all)**

Operable windows offer the advantage of personal comfort control and beneficial connections to the environment. However, individual operation of the windows not in coordination with the HVAC system settings and requirements can have extreme impacts on the energy use of a building's system. Advanced energy buildings with operable windows should strive for a high level of integration between envelope and HVAC system design. First, the envelope should be designed to take advantage of natural ventilation with well-placed operable openings. Second, the mechanical system should employ interlocks on operable windows to ensure that the HVAC system responds by shutting down in the affected zone if the window is opened. It is important to design the window interlock zones to correspond as closely as possible to the HVAC zone affected by the open window.

## Warm Climates

### EN26 *Building Form and Window Orientation* (Climate Zones: 1 2 3 4 5 6)

In warm climates, north and south glass can be more easily shielded and can result in less solar heat gain and less glare than do east- and west-facing glass. During site selection, preference should be given to sites that permit elongating the building in the east-west direction and that permit orienting more windows to the north and south. See Figure 4-18.

A good design strategy avoids areas of glass that do not contribute to the view from the building or to the daylighting of the space. If possible, configure the building to maximize north-facing walls and glass by elongating the floor plan. Since sun control devices are less effective on the east and west façades, the solar penetration through the east- and west-facing glazing should be considerably less than that through the north- and south-facing glazing. This can be done by reducing the area of glazing, reducing the SHGC, or preferably both. Thus, the area of glazing on the east and west façades, times their respective SHGCs, should be less than the area of glazing on the north and south façades times their respective SHGCs. If each façade has a different area or SHGC, the formula becomes:  $((W \text{ window area} \times W \text{ SHGC}) + (E \text{ window area} \times E \text{ SHGC})) < (\text{less than}) ((N \text{ window area} \times N \text{ SHGC}) + (S \text{ window area} \times S \text{ SHGC}))$ . For buildings where a predominantly east-west exposure is unavoidable, or if the application of this equation would result in SHGCs of less than 0.25, then more aggressive energy conservation measures may be required in other building components to achieve an overall 30% energy savings.

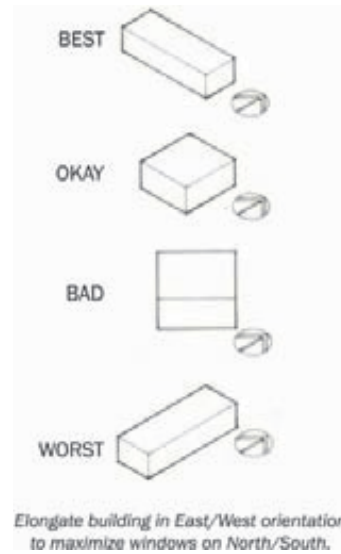

**Figure 4-18.** (EN26) Building and window orientation.

### EN27 *Glazing* (Climate Zones: 1 2 3 4 5 6)

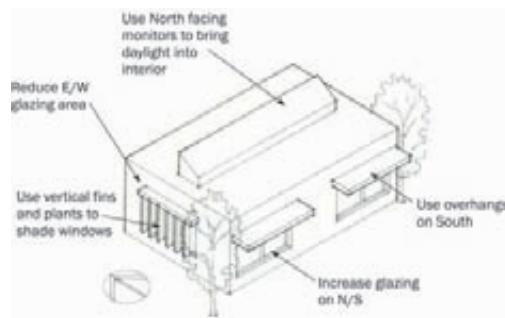

**Figure 4-19.** (EN27) Exterior sun control.

For north- and south-facing windows, select windows with a low solar heat gain coefficient and an appropriate visible light transmission (VLT). See EN32. Certain window coatings, called selective low-e, transmit the visible portions of the solar spectrum selectively, rejecting the nonvisible infrared sections. These glass and coating selections provide superior view and daylighting, while minimizing solar heat gain. Window manufacturers market special “solar low-e” windows for warm climates. For buildings in warm climates that do not utilize daylight-responsive lighting controls, north and south window glazing should be selected with a solar heat gain coeffi-

cient (SHGC) of no more than 0.35. East- and west-facing windows in warm climates should be selected for an SHGC of no more than 0.25. All values are for the entire fenestration assembly, in compliance with NFRC procedures, and are not simply center-of-glass values. For warm climates, a low SHGC is much more important for low building energy consumption than the window assembly U-factor. Windows with low SHGC values will tend to have a low center-of-glass U-factor, however, because they are designed to reduce the conduction of the solar heat gain absorbed on the outer light of glass through to the inside of the window.

**EN28**      ***Obstructions and Planting (Climate Zones: all)***

Adjacent taller buildings and trees, shrubs, or other plantings are effective to shade glass on south, east, and west façades. For south-facing windows, remember that the sun is higher in the sky during the summer, so that shading plants should be located high above the windows to effectively shade the glass. See Figure 4-19. The glazing of fully shaded windows can be selected with higher SHGC ratings without increasing energy consumption. The solar reflections from adjacent building with reflective surfaces (metal, windows or especially reflective curtain walls) should be considered in the design. Such reflections may modify shading strategies, especially on the north façade.

**Cold Climates**

**EN29**      ***Window Orientation (Climate Zones: all)***

For more northerly locations, only the south glass receives much sunlight during the cold winter months. If possible, maximize south-facing windows by elongating the floor plan in the east-west direction and relocate windows to the south face. Be careful to install blinds or other sun control devices for the south-facing glass that allow for passive effects when desired but prevent unwanted glare and solar overheating. Glass facing east and west should be significantly limited. Areas of glazing facing north should be cautiously sized for daylighting and view. During site selection, preference should be given to sites that permit elongating the building in the east-west direction and that permit orienting more windows to the south. See also DL5 and Figure 4-18.

**EN30**      ***Passive Solar (Climate Zones: all)***

Passive solar energy-saving strategies should be limited to non-office spaces, such as lobbies and circulation areas, unless those strategies are designed so that workers do not directly view interior sun patches or see them reflected in computer screens. Consider heat-absorbing blinds. In spaces where glare is not an issue, the usefulness of the solar heat gain collected by these windows can be increased by using hard massive floor surfaces, such as tile or concrete, in the locations where the transmitted sunlight will fall. These floor surfaces absorb the transmitted solar heat gain and release it slowly over time, to provide a more gradual heating of the structure. Consider low-e glazing with exterior overhangs.

**EN31**      ***Glazing (Climate Zones: all)***

Higher SHGCs are allowed in colder regions, but continuous horizontal overhangs are still necessary to block the high summer sun angles. Window manufacturers market low-e windows designed especially for cold climates.

## Window Design Guidelines for Daylight

### Good Design Practice

#### EN32 *Visual Light Transmission (VLT) (Climate Zones: 1 2 3 4 5 6)*

The amount of light transmitted in the visible range affects the view through the window, glare, and daylight harvesting. These functions are not always best served by the same glazing product. For the effective utilization of daylight, the highest VLTs (0.50 - 0.70) should be used in the glazing located between 6 ft above the floor up to the ceiling. The view windows below 6 ft do not require such high VLTs, so values between 0.35 and 0.50 are acceptable to achieve recommended SHGC values. Higher VLTs are preferred in predominantly overcast climates. VLTs below 0.35 may appear noticeably tinted and dim to occupants and may degrade luminous quality. However, lower VLTs may be required to prevent glare, especially on the east or west façades or for higher window-wall ratios. Lower VLTs may also be appropriate for other conditions of low sun angles or light-colored ground cover (such as snow or sand), but adjustable blinds should be used to handle intermittent glare conditions that are variable.

#### EN33 *Color-Neutral Glazing (Climate Zones: all)*

The desirable color qualities of daylighting are best transmitted by neutrally colored tints that alter the color spectrum to the smallest extent. In particular, avoid green and bronze colored glazing.

#### EN34 *Reflective Glass (Climate Zones: all)*

To the greatest extent possible, avoid the use of reflective glass or low-e coatings with a highly reflective component. These reduce the quality of the view and the mirrored effect is unpleasant to occupants after dark.

#### EN35 *Light to Solar Ratio (Climate Zones: all)*

The use of high-performance and selective low-e glazing reduces the visual light transmission (VLT) proportionately less than do reflective coatings or tints. Dividing the VLT by the solar heat gain coefficient (SHGC) is a good rating of the performance of the glass. If the result is less than 1.0, then the glass is a poor choice for visual quality and daylighting. If the result is higher than 1.55, it is a high-performance option.

#### EN36 *Effective Aperture (Daylight) (Climate Zones: all)*

The window-wall ratio (WWR) times the visual light transmission (VLT) in an individual space results in the “effective aperture,” predicting the daylighting potential of the glazing. Depending on the latitude and predominant sky conditions (clear or overcast), effective apertures for daylighting are generally between 0.15 and 0.30. The smallest effective aperture that will meet daylighting needs should be pursued. It is unlikely that sufficient daylighting savings or user acceptance will be realized with effective apertures much less than 0.15. Increases in either the WWR or the VLT will have a corresponding impact on the thermal characteristics of the glazing system. Balance the visual requirements of the daylighting design with the thermal comfort and performance of the building envelope and HVAC system.

**EN37 Preferred Window-Wall Ratios (WWR) (Climate Zones: all)**

For view and a positive connection to the out-of-doors, people prefer a minimum 20% to 30% ratio of window area to wall area. Glazing the wall areas below desk height (0-30 in. above the floor) offers little or no benefits for daylighting an office.

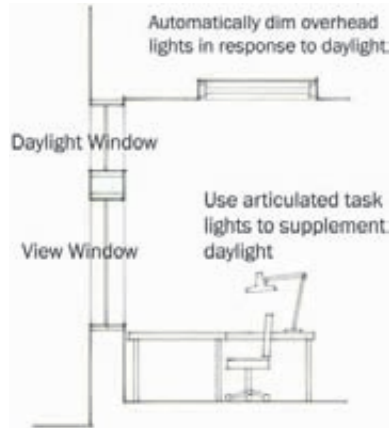
**EN38 (Climate Zones: all)**

High, continuous windows are more effective than individual or vertical windows to distribute light deeper into the space and provide greater comfort for the occupants. Try to locate the top of windows close to the ceiling line (for daylighting) but locate the bottom of windows no higher than 48 in. (for view). Consider separating windows into two horizontal strips, one at eye level for view and one above to maximize daylight penetration. See Figure 4-20.

**Figure 4-20.** (EN38) Daylight window and view window.

**EN39 High Ceilings (Climate Zones: all)**

More daylight savings will be realized if ceiling heights are 10 ft or higher. Greater daylight savings can be achieved by increasing ceiling heights to 11 ft or higher and specifying higher VLTs (0.60-0.70) for the daylight window than for the view windows. North-facing clerestories are more effective than skylights to bring daylight into the building interior.

**EN40 Light Shelves (Climate Zones: all)**

Consider using interior or exterior light shelves between the daylight window and the view window. These are effective for achieving greater uniformity of daylighting and for extending ambient levels of light onto the ceiling and deeper into the space. Some expertise and analysis will be required to design an effective light shelf. See Figure 4-21.

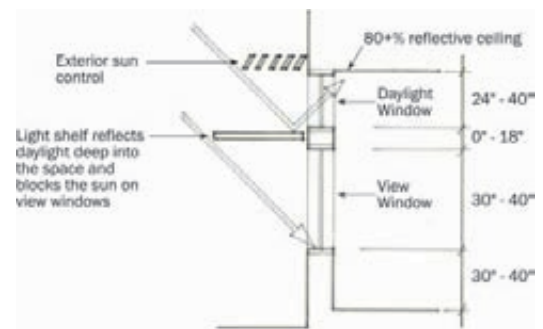

**Figure 4-21.** (EN40) Wall section for daylighting.

**EN41 Window and Office Placement (Climate Zones: all)**

Daylighting is more cost-effective if open plan workstations are located on the north and south sides of the building since open plan areas are more continuously occupied and achieve lower savings from occupancy sensors. The open configuration also absorbs less light, and interreflections provide a more uniform distribution of light deep into the space. The control of heat and glare on the east and west façades is difficult because daylight and views are blocked in an effort to properly control the low sun angles of morning and evening hours. By placing private offices on the east and west, occupants can individually control their blinds and thereby control thermal discomfort and glare.

**EN42 Interior Sun Control (Climate Zones: all)**

Similar to exterior sun control, horizontal blinds on the south windows and vertical blinds on the east and west are most effective. In northern latitudes, low angles of sun can enter the north windows on summer mornings and afternoons. Vertical blinds that retract fully for the middle of the day are recommended for these conditions. Perforated blinds and translucent shades may cause glare when hit by direct sunlight.

**References**

- IESNA. 1997. *EPRI Daylight Design: Smart & Simple*. New York: Illuminating Engineering Society of North America.
- LBL. *Daylight and Windows*. LBL Tips for Daylighting with Windows. Berkeley, Calif.: Lawrence Berkeley National Laboratories. <http://windows.lbl.gov/daylighting/designguide/designguide.html>
- Evans, Benjamin. 1997. *Daylighting Design, Saver Standards for Architectural Design Data*. New York: McGraw-Hill.

**LIGHTING**

---

**Daylighting****Good Design Practice****DL1 Savings and Occupant Acceptance (Climate Zones: all)**

Daylighting will only save energy if the electric lighting consumption is reduced and heat gain and loss through glazing is controlled. In addition, glare and contrast must be controlled so occupants are comfortable and will not override electric lighting controls. See additional comments related to window design and placement (EN32 through EN41).

**DL2 Occupancy Sensors and Task Lighting (Climate Zones: all)**

Use of “manual-on” occupancy sensors in daylighted spaces saves energy because electricity is not automatically consumed unnecessarily. Use of local articulated task lights (desk lamps that can be adjusted in three planes) in daylighted spaces increases occupant satisfaction and is an effective supplement for daylighting. See Figure 4-20.

**DL3 Surface Reflectances (Climate Zones: all)**

The use of light-colored materials and matte finishes in all daylighted spaces increases efficiency through interreflections and greatly increases visual comfort. See EL3.

**DL4 Furniture Partitions (Climate Zones: all)**

Lower furniture partitions in open plan office areas increase the efficiency of both the daylighting and the electric lighting system by reducing absorption and unwanted shadows. See EN41 and EL1.

## Cautions

The Recommendations in chapter 3 will only be successful and acceptable to owner and occupants if the lighting design safeguards for the quality and quantity of light are met:

### **DL5** *Control of Direct Sun Penetration (Climate Zones: all)*

- Shield workspaces from direct sun. Use exterior and interior sun control devices to control glare and solar heat gain.
- Use continuous exterior overhangs and horizontal blinds on south elevations. Use interior vertical slat blinds to control glare and low angle sun penetration, particularly on east- and west-facing glazing and when required for NE or NW façades or north façades at higher latitudes.
- For “toplighting,” use north-facing clerestories to control direct sun.
- For skylights, use light-reflecting baffles and/or diffusing glazing to control direct sun. Note that diffusing skylights can cause glare when the sun hits them.

Daylighting utilizes light from the sky, either in its brightest intensity on a clear sunny day or in a diffuse form on a cloudy or hazy day. Patches of direct sunlight in the employees’ view create unacceptable brightness and excessive contrast between light and dark room surfaces. Exterior sun control or overhangs help reduce both glare and heat gain for vertical glazing surfaces.

An exterior overhang needs to be deep enough to shield windows above the light shelf (if used) from direct sun. The light shelf should also be deep enough to shield windows below the shelf from direct sun. See Figure 4-21.

### **DL6** *Orientation of Workstations to Vertical Glazing (Climate Zones: all)*

Orient workstations with computer monitors at  $90^\circ$  ( $\pm 30^\circ$ ) to windows. It is visually stressful for workers to view a computer monitor while simultaneously viewing a bright sunlit scene outside the window, as is dealing with the reflection in a computer screen from a bright window or skylight. Workstations should be oriented to avoid either of these conditions. At the very least, the workers should have the ability to tilt and swivel their computer monitors.

### **DL7** *Skylight Thermal Transmittance (Climate Zones: all)*

#### **Hot Climates**

- Reduce thermal gain during the cooling season by using skylights with a low overall thermal transmittance. This overall U-factor includes the glazing only.
- Use north-facing clerestories for skylighting whenever possible in hot climates to eliminate excessive solar heat gain and glare.
- Shade skylights on south-, east-, and west-oriented sloping roofs with exterior sun control such as screens, baffles, or fins.
- Use smaller aperture skylights in a grid pattern to gain maximum usable daylight with the least thermal heat transfer.

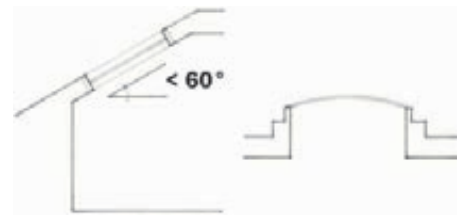

**Figure 4-22.** (DL7) Skylight (horizontal fenestration).



### **Moderate and Cooler Climates**

- Reduce summer heat gain as well as winter heat loss by using skylights with a low overall thermal transmittance. The overall U-factor includes the glazing as well as the frame and/or curb. Use a skylight frame that has a thermal break to prevent excessive heat loss/gain and winter moisture condensation on the frame. Insulate the skylight curb above the roof line with continuous rigid insulation.
- Use either north- or south-facing clerestories for skylighting but not east or west. East-west glazing adds excessive summer heat gain and makes it difficult to control direct solar gain. Clerestories with operable glazing may also help provide natural ventilation in temperate seasons when air conditioning is not in use.
- Use skylights with smaller apertures in a grid pattern to gain maximum usable daylight with the least thermal heat transfer. Do not exceed maximum prescribed glazing area.

#### **DL8 Interactions (Climate Zones: all)**

Thermal gains and losses associated with windows should be balanced with daylight-related savings achieved by reducing electric lighting consumption.

### **References**

- IESNA. 1997. EPRI Daylighting Design: Smart and Simple. New York: Illuminating Engineering Society of North America.
- NBI. Advanced Lighting Guidelines. White Salmon, Wash.: New Buildings Institute.

### **Daylighting Controls**

#### **DL9 Expanded Recommendations for Daylighting Controls (Climate Zones: all)**

The following recommendations will be necessary to achieve the 30% energy savings calculated for buildings with a 25% window-wall ratio or higher.

- **Dimming controls.** In office work areas, continuously dim rather than switch electric lights in response to daylight to minimize employee distraction. Specify dimming ballasts that dim down to at least 20% of full output. Automatic multi-level daylight switching may be used in non-office environments such as hallways, storage, restrooms, lounges, lobbies, etc. Locate luminaires in rows parallel to the window wall and wire each row separately, if located in the daylight zone (within 12 ft from the window wall). The daylighting control system and/or photosensor should include a five-minute time delay or other means to avoid cycling caused by rapidly changing sky conditions and a one-minute fade rate to change the light levels by dimming.
- **Correct photosensor placement is essential:** Consult daylighting references or work with photosensor manufacturer for proper location. Photosensors mounted in luminaires may not achieve optimum sensor placement.
- **Photosensor specifications.** Photosensors used for offices should be specified for the appropriate illuminance range (indoor or outdoor) and must achieve a slow, smooth linear dimming response from the dimming ballasts. When a daylighting system is designed to read the combined illuminance from daylight and electric light sources (a “closed loop” system), photocells must have filtering or another strategy to achieve an equal response to the color spectra of the different sources.

- **Calibration and commissioning are essential:** All lighting controls must be calibrated and commissioned after the furniture is in place but *prior* to occupancy. Include requirements in the specifications.

## Good Design Practice

### *DL10 Photo sensor placement (Climate Zones: all)*

A “closed loop” system is one where the interior photocell responds to the combination of daylight and electric light on the primary work surface. The best location for the photocell is above an unobstructed location such as an interoffice circulation path. The photocell is adjusted to achieve the desired light level at a light meter placed on the worst-case desktop. An “open loop” system is one where the photocell responds only to daylight levels but is still calibrated to the desired light level received at a desktop. The best location for the photo sensor is inside the window frame or skylight well.

## Cautions

The Recommendations in chapter 3 will only be successful and acceptable to owner and occupants if the lighting design safeguards for the quality and quantity of light are met.

### *DL11 Calibration and Commissioning (Climate Zones: all)*

Even a few days of occupancy with poorly calibrated controls can lead to permanent overriding of the system and loss of all savings. Most photosensors require a daytime and nighttime calibration session. The photosensor manufacturer and the quality assurance provider should be involved in the calibration.

### *DL12 Daylight Levels (Climate Zones: all)*

Occupants expect higher combined light levels in daylighted spaces. Consequently, it is more acceptable to occupants when the electric lights are calibrated to dim when the combined daylight and electric light on the worksurface exceeds 1.20 times the designed light level; i.e., if the ambient electric light level is designed for 35 maintained footcandles, the electric lights should begin to dim when the combined level is 42 footcandles. ( $35 \times 1.20 = 42$ ). Local task lighting can supplement this level but should be turned off during the calibration process.

### *DL13 Interactions (Climate Zones: all)*

Energy savings due to reduced electrical consumption from daylighting should be weighed against any potential loss caused by increased cooling or heating loads.

## References

- IESNA. 1997. EPRI Daylighting Design: Smart and Simple. New York: Illuminating Engineering Society of North America.
- IESNA. 1996. EPRI Lighting Controls—Patterns for Design. New York: Illuminating Engineering Society of North America.
- NBI. NBI Advanced Lighting Guidelines. White Salmon, Wash.: New Buildings Institute.

## Electric Lighting Design

### Interior Lighting

#### Good Design Practice

##### *EL1* **Lighting Walls and Ceilings (Climate Zones: all)**

Better eye adaptation and luminous comfort are achieved when light is distributed to the walls and ceilings. Totally direct solutions should be avoided, since they create harsh shadows and dim rooms. To light walls, use wall wash luminaires or locate fixtures closer to walls. In open plan offices, lower furniture partitions and translucent partitions are more energy efficient than higher partitions for both daylighting and electric lighting.

##### *EL2* **Task Lighting (Climate Zones: all)**

Consider hardwiring the lower output level of a two-stepped T8 electronic ballast (ballast factor 0.40 to 0.50) for undercabinet lighting, since full output is too bright and wastes energy. Use “articulated” task lights (i.e., adjustable in three planes by the worker) with compact fluorescent sources for desktops. Provide local switches on task lighting, or connect them to specialized plugstrips controlled by local occupancy sensors.

##### *EL3* **Reflectances (Climate Zones: all)**

A 90% ceiling reflectance is preferred for indirect luminaires and daylighting. Reflectance values are available from paint and fabric manufacturers. Reflectances should be verified by the quality assurance provider. Avoid shiny surfaces (mirrors, polished metals, or stone) in work areas. See DL3.

##### *EL4* **Lamps and Ballasts (Climate Zones: all)**

To achieve the maximum  $0.9 \text{ W/ft}^2$  connected load recommended in chapter 3, “high performance” T8 lamps and instant start ballasts were assumed. High-performance T8 lamps are defined, for the purpose of this document, as having a lamp/ballast efficacy of 92 lumens per watt, based on “mean lumens” (published in the lamp catalogs as the degraded lumen output occurring at 40% of the lamp’s rated life) and the input watts of a very efficient two-lamp parallel Instant Start electronic ballast. High-performance T8s also are defined as having a CRI of 85 or higher and a 92% lumen maintenance over their rated life. The higher performance is achieved either by increasing the output (3100 lumens) while keeping the same 32-watt input as standard T8s or by reducing the wattage while keeping the light output similar to standard T8s (e.g., 2750 lumens for 28 watts or 2850 lumens for 30 watts). The higher output 3100-lumen versions are visibly brighter than standard T8s, but a ballast with a BF of 0.77 may be used to provide a more comfortable lamp brightness above work stations without sacrificing efficiency. Program Start ballasts are recommended on frequently switched lamps (switched on and off more than five times a day) because they greatly extend lamp life over frequently switched Instant Start ballasts. Instant Start T8 ballasts typically provide greater energy savings and are the least costly option, plus the parallel operation allows one lamp to operate even if the other burns out. However, an Instant Start ballast may reduce lamp life, especially when controlled by occupancy sensors in rooms such as corridors, toilets, and interior offices. T5 ballasts should always be Program Start.

**EL5 Occupancy Sensors (Climate Zones: all)**

The greatest energy savings are achieved with manual On, automatic Off occupancy sensors in daylighted spaces. This avoids unnecessary operation when electric lights are not needed and greatly reduces the frequency of switching. In open plan offices, ceiling-mounted ultrasonic sensors should be connected to an automatic or momentary contact switch so

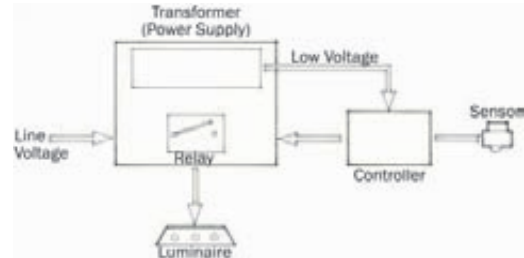

**Figure 4-23.** (EL5) Occupancy-sensing control.

that the operation always reverts to manual On after either manual or automatic turn Off. Automatic time scheduling is an alternative to occupancy sensors in open plan offices. In private offices, infrared wall box sensors should be pre-set for manual On automatic Off operation. In nondaylighted areas, ceiling-mounted occupancy sensors are preferred. In every application it should not be possible for the occupant to override the automatic Off setting, even if set for manual On. Unless otherwise recommended, factory-set occupancy sensors should be set for medium to high sensitivity and a 15-minute time delay (the optimum time to achieve energy savings without excessive loss of lamp life). Work with the manufacturer for proper placement, especially when partial-height partitions are present.

**EL6 Multi-Level Switching (Climate Zones: all)**

Consider going beyond the minimum control requirements of local codes or Standard 90.1-1999, by providing more discrete levels of switching controls. Label all switches. Specify luminaires with multiple lamps to be factory wired for inboard-outboard switching or inline switching. The objective is to have each level of light uniformly distributed. Avoid checkerboard patterns. Avoid nonuniform switching patterns unless different areas of a large space are used at different times.

**EL7 Electric Lighting and Daylight Controls (Climate Zones: all)**

Factory-setting of calibrations should be specified when feasible to avoid field labor. Lighting calibration and commissioning should be performed after furniture installation but *prior* to occupancy to ensure user acceptance.

**EL8 Exit Signs (Climate Zones: all)**

Use LED exit signs or other sources that consume no more than 5 watts per face. The selected exit sign and source should provide the proper luminance to meet all building and fire code requirements.

## Options

**EL9 Fluorescent T5 Sources (Climate Zones: all)**

T5HO and T5 lamps may be part of a solution. They have initial lumens per watt that compare favorably to the high-performance T8. In addition to energy, T5s use fewer natural resources (glass, metal, phosphors) than a comparable lumen output T8 system. However, when evaluating the lamp and ballast at the “mean lumens” of the lamps, T5HO lamps perform more poorly. On instant start ballasts,

high-performance T8s are 13% more efficient than T5s. In addition, since T5s have higher surface brightness and should not be used in open-bottom fixtures, it may be difficult to achieve the 30% savings and maintain the desired light levels using current T5 technology as the primary light source.

**EL10** *Light Fixture Distribution (Climate Zones: all)*

Recessed direct fixtures may meet the watts per square foot allowance and the illuminance recommendations for offices, but they do not provide the same quality of light as pendant direct-indirect lighting fixtures. Extensive use of totally indirect luminaires or recessed direct-indirect (coffer-type) fixtures may not achieve the desired light levels while meeting the 0.9 W/ft<sup>2</sup> goal.

**Sample  
Design  
Layouts for  
Office  
Buildings**

The 0.9 W/ft<sup>2</sup> goal for lighting power (shown in each Recommendation Table in chapter 3) represents an average lighting power density for the entire building. Individual spaces may have higher power densities if they are offset by lower power densities in other areas. The example design described below is one way (but not the only way) that this watts-per-square-foot limit can be met. Daylight controls (see DL9) are assumed in all open office plans and under all skylights (see DL7).

**EL11** *Open Plan Office (Climate Zones: all)*

The target lighting in open offices is 30 average maintained footcandles for ambient lighting with a total of at least 50 footcandles provided on the desktop by a combination of the ambient and supplemental task lighting.

Open plan offices account for approximately 20% of the floor area. Assuming an 8 foot by 8 foot work station and a 4 foot center aisle, this layout is about 1.03 W/ft<sup>2</sup> including task lighting wattage. Use daylight dimming ballasts and photocell control in daylight zone (within 12 feet of window wall) if WWR is greater than 25% in this area. Use occupancy sensor local control or scheduling on all luminaires.

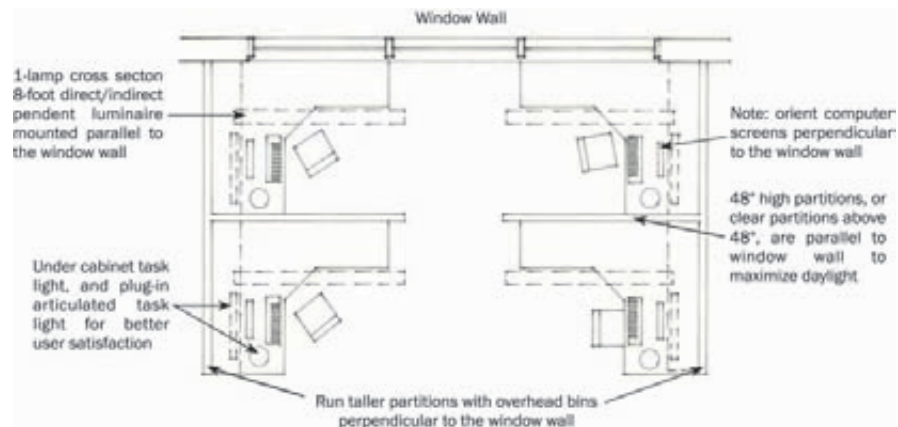
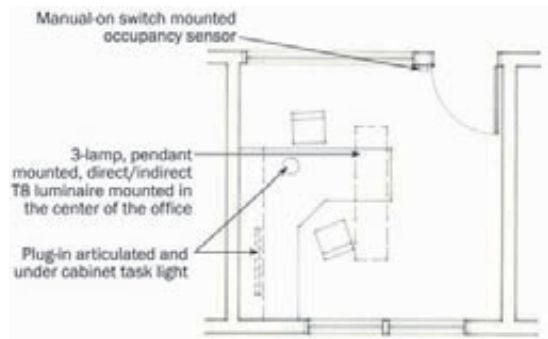

**Figure 4-24.** (EL11) Layout for open plan office.

**EL12 Private Office (Climate Zones: all)**

The target lighting in private offices is 30 average maintained footcandles for ambient lighting with a total of at least 50 footcandles provided on the desktop by a combination of the ambient and supplemental task lighting.

Private office plans account for approximately 25% of the floor area. Assuming a 10 foot by 12 foot office, this layout is about 0.94 W/ft<sup>2</sup> including task lighting wattage. Use occupancy sensor local control.

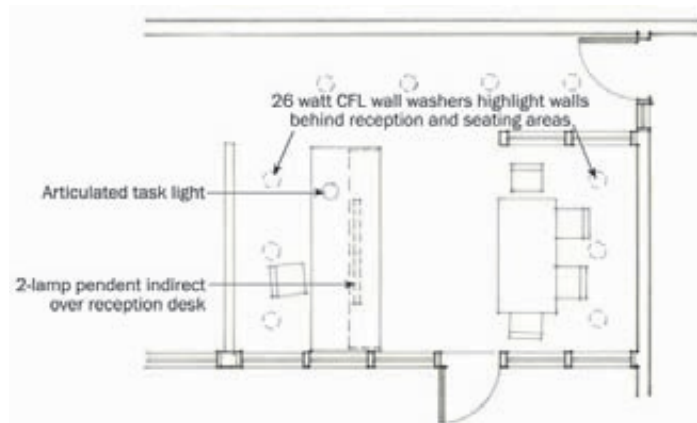

**Figure 4-25.** (EL12) Layout for private office.

**EL13 Lobbies (Climate Zones: all)**

The target lighting in the lobby is 10-15 average maintained footcandles. High-light wall surfaces and building directory.

Lobbies account for approximately 10% of the floor area. The layout in Figure 4-26 is about 1.09 W/ft<sup>2</sup>.

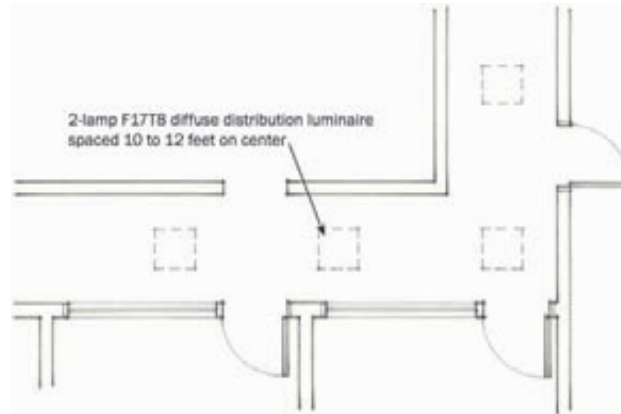

**Figure 4-26.** (EL13) Layout for lobby.

**EL14 Corridors**

The target lighting in the corridors is 5-10 average maintained footcandles. Choose luminaires that light the walls and provide relatively uniform illumination.

Corridors account for approximately 10% of the floor area. Optional layouts using one-lamp 1 × 4 or 26-watt CFL sconce or ceiling luminaires may be used to minimize the number of lamp types on the project. This layout yields 0.55 W/ft<sup>2</sup> when spaced 12 feet on center in a 5-foot-wide corridor.

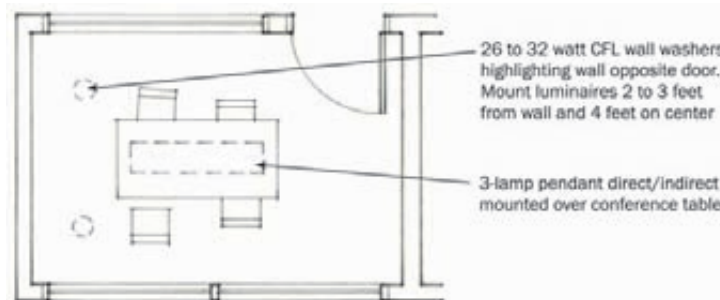

**Figure 4-27.** (EL14) Layout for corridors.

**EL15** *Conference/Meeting Rooms (Climate Zones: all)*

The target lighting in the conference room is 30-40 average maintained footcandles. Use occupancy sensor local control.

Conference rooms account for approximately 10% of the floor area. The layout in Figure 4-28 is about 1.02 W/ft<sup>2</sup>.



**Figure 4-28.** (EL15) Layout for Conference/meeting rooms.

**EL16** *Storage (Climate Zones: all)*

The target lighting in the storage is 5-15 average maintained footcandles.

Storage areas account for approximately 15% of the floor area. The layout in Figure 4-29 is about 0.78 W/ft<sup>2</sup>.

**Note:** Lighting in remaining 10% of the office space is composed of various functions including restrooms, electrical/mechanical rooms, stairways, workshops, and others. Average the connected load in these spaces to 0.75 W/ft<sup>2</sup>, which is equivalent to about one two-lamp high-performance T8 luminaire every 80 ft<sup>2</sup>. Use occupancy sensors or timers where appropriate.

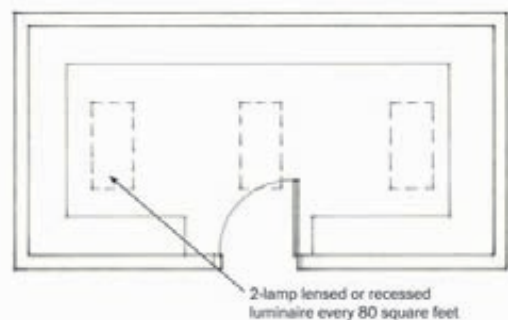

**Figure 4-29.** (EL16) Layout for storage area.

The designed lighting power density does not exceed the recommended 0.90 W/ft<sup>2</sup> for the total building interior.

## Cautions

The recommendations in chapter 3 will only be successful and acceptable to owner and occupants if the following lighting design safeguards for the quality and quantity of light are met:

### **EL17** *Overhead Glare Control (Climate Zones: all)*

Specify luminaires properly shielded for worker comfort. Avoid T5 lamps in open-bottomed fixtures. Avoid specular (shiny) louvers, cones, or reflectors visible to occupants from any angle. Use efficient fixtures and proper distribution. Include the partial height partitions in lighting calculations and for spacing. Use more fixtures of lower wattage rather than the reverse.

## References

*Know-How Guide for Office Lighting*, available at [Designlights.org](http://Designlights.org)

*NBI Advanced Lighting Guidelines*, available at [newbuildings.org](http://newbuildings.org)

*EPRI Lighting Controls Smart and Simple*, available from IESNA at [IESNA.org](http://IESNA.org)

*ANSI/IESNA RP-1-04, Recommended Practice on Office Lighting*, available from IESNA at [IESNA.org](http://IESNA.org)

## HVAC

---

## Good Design Practice

### **HV1** *General (Climate Zones: all)*

The HVAC equipment for this Guide includes packaged unit systems and split systems generally referred to as air conditioning or heat pump units that are warm air heating systems. These systems are suitable for projects with no central plant. This Guide does not cover water-source or ground-source heat pumps nor systems that use liquid water chillers or purchased chilled water for cooling nor oil, hot water, solar, steam, or purchased steam for heating. These systems are alternative means that may be used to achieve 30 percent or greater savings over Standard 90.1-1999 and where used, the basic principles of this Guide would apply.

The systems included in this Guide are available in pre-established increments of capacity and are characterized with an integral refrigeration cycle and heating source. The components are factory designed and assembled and include fans, motors, filters, heating source, cooling coil, refrigerant compressor, controls, and condenser. The components can be in a single package or a split system that separates the evaporator and condenser sections.

Performance characteristics vary among manufacturers, and the selected equipment should match the calculated heating loads and sensible and latent cooling loads and take into account the importance of meeting latent cooling loads under part-load conditions. See HV3 “Cooling and Heating Loads,” for calculating the loads; HV4 “Humidity Control,” for meeting latent cooling loads under part load conditions, and HV13 “Thermal Zones,” for recommendations on zoning the building. See HV21 “Zone Temperature Control,” for a discussion on location of space thermostats. The equipment should be listed as being in conformance with electrical and safety standards, and its performance ratings should be certified by a nationally recognized certification program.



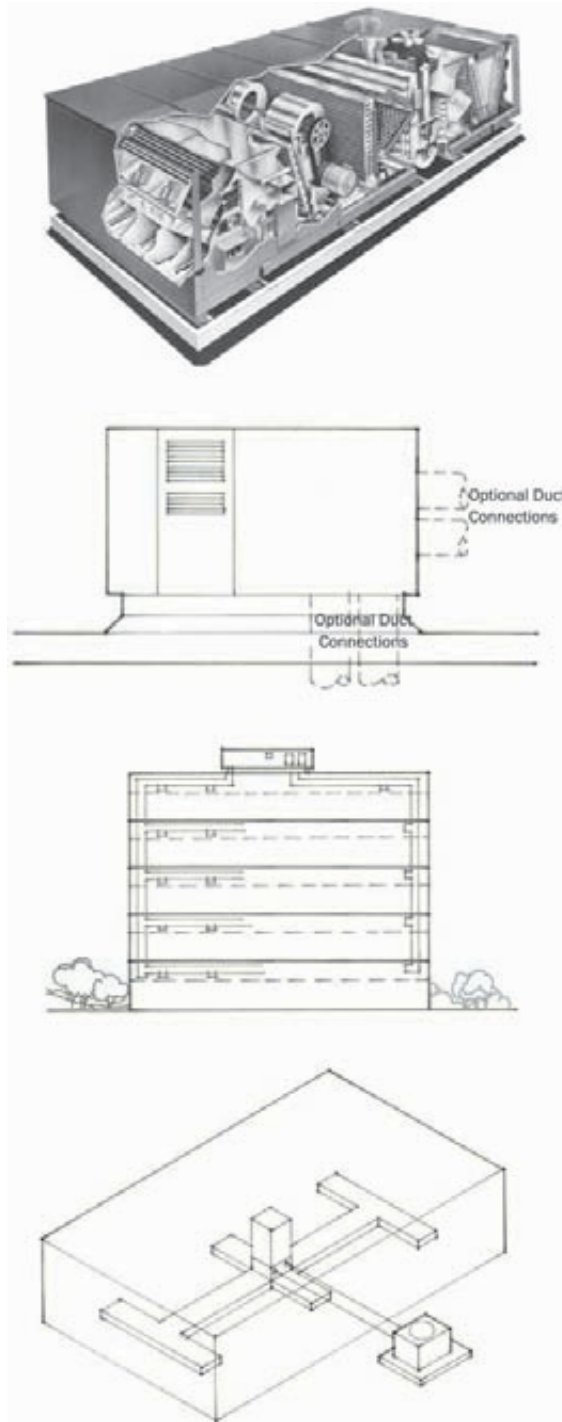

**Figure 4-30.** (HV1) Typical HVAC equipment and duct system layouts.

Single packaged units could be mounted on the roof, at grade level, or indoors. Split systems generally have the blower unit, including filters and coils, located indoors or outdoors and the condensing unit outdoors on the roof or at grade level. On smaller systems, the blower is commonly incorporated in an indoor furnace section. The blower unit may also be located outdoors, and if so, it should be mounted on the roof to avoid ductwork outside the building envelope. See HV9 for a further discussion on the ductwork recommendations. The equipment should be located in a position that results in minimizing fan power, ducting, and wiring.

Heating fuel sources include natural gas, propane, and electric resistance.

## ***HV2 HVAC System Types (Climate Zones: all)***

This Guide considers packaged unit systems and split systems with a refrigerant-based direct expansion (DX) system for electric cooling and heating by means of one of the three following options:

1. Option 1: Indirect gas-fired heater.
2. Option 2: Electric resistance heat.
3. Option 3: Heat pump unit.

Indirect gas-fired heaters use a heat exchanger as part of the factory-assembled unit to separate the burner and products of combustion from the circulated air.

Electric resistance heaters are part of the factory-assembled unit and do not refer to electric resistance heaters installed in the duct distribution system.

The auxiliary heat source for heat pump units may also be used to supply heating to the space during the defrost cycle and can be either electric or gas.

Where variable air volume systems are used, the DX coil should be a full-face, intertwined-type coil to prevent bypass of air through sections of the coil without refrigerant flow. The controls of a variable air volume system should be arranged to reduce the supply air to the minimum setpoint for ventilation before reheating, recooling, or mixing of air occurs. Variable speed drives should be used to reduce airflow and fan/motor energy and maintain stable fan and refrigeration operation.

## ***HV3 Cooling and Heating Loads (Climate Zones: all)***

Heating and cooling system design loads for the purpose of sizing systems and equipment should be calculated in accordance with generally accepted engineering standards and handbooks such as *ASHRAE Handbook—Fundamentals*. Any safety factor applied should be done cautiously and applied only to a building's internal loads to prevent oversizing of equipment. If the unit is oversized and the cooling capacity reduction is limited, short cycling of compressors could occur and the system may not have the ability to dehumidify the building properly. Include the cooling and heating load of the outdoor air to determine the total cooling and heating requirements of the unit. In determining cooling requirements, the sensible and latent load to cool the outdoor air to room temperature must be added to the building cooling load. For heating, the outdoor air temperature must be heated to the room temperature and the heat required added to the building heat loss. On variable air volume systems, the minimum supply airflow to a zone must comply with local code, ASHRAE Standard 62, and Standard 90.1 and should be taken into account in calculating heating loads of the outdoor air.

## ***HV4 Humidity Control (Climate Zones: all)***

The sensible load in the building does not decrease proportionately with the latent load, and as a result, the space relative humidity can increase under cooling part-load conditions. Examine the system performance at part load to ensure that

the space relative humidity remains below 60 percent when the sensible load is at 50 percent of peak design. For part loads and variable air volume systems, multiple compressors are desirable to reduce the capacity as low as possible to meet the minimum cooling requirements and operate efficiently at part loads. On systems with multiple compressors, the compressors turn on or off or unload to maintain the space air temperature setpoint. On systems that employ supply air temperature reset, controls must be added to ensure that the relative humidity within the space does not exceed 60 percent.

#### ***HV5 Energy Recovery (Climate Zones: all)***

Total energy recovery equipment can provide an energy-efficient means to deal with the latent and sensible outdoor air cooling loads during peak summer conditions. It can also reduce the required heating of outdoor air in cold climates. Exhaust air energy recovery can be provided through a separate energy recovery ventilator that conditions the outdoor air before entering the air-conditioning or heat pump unit, an energy recovery unit that attaches to an air-conditioning or heat pump unit, or an air-conditioning or heat pump unit with the energy recovery unit built into it.

For maximum benefit, energy recovery designs should provide as close to balanced outdoor and exhaust airflows as is practical, taking into account the need for building pressurization and any exhaust that cannot be incorporated into the system. Exhaust for energy recovery units may be taken from spaces requiring exhaust (using a central exhaust duct system for each unit) or directly from the return air stream (as with a unitary accessory or integrated unit).

Where economizers are used with an energy recovery unit, the energy recovery system should be controlled in conjunction with the economizer and provide for the economizer function. Where energy recovery is used without an economizer, the energy recovery system should be controlled to prevent unwanted heat, and an outdoor air bypass of the energy recovery equipment should be used. In cold climates, manufacturer's recommendations for frost control should be followed.

#### ***HV6 Equipment Efficiency (Climate Zones: all)***

The cooling equipment should meet or exceed the listed SEER (seasonal energy efficiency ratio) or EER (energy efficiency ratio) for the required capacity. The cooling equipment should also meet or exceed the IPLV (integrated part-load value) where shown.

Heating equipment should meet or exceed the listed AFUE (annual fuel utilization efficiency) or Thermal Efficiency for indirect gas-fired heater at the required capacity. For heat pump applications, the heating efficiency should meet or exceed the listed HSPF (heating seasonal performance factor) or COP (coefficient of performance) for the required capacity based on 47°F outdoor air temperature.

#### ***HV7 Ventilation Air (Climate Zones: all)***

The amount of outdoor air should be based on ANSI/ASHRAE Standard 62-2001 but in no case be less than the values required by local code. The number of people used in computing the ventilation quantity required should be based on either the known occupancy, local code, or Standard 62.

Each air-conditioning or heat pump system should have an outdoor air connection through which ventilation air is introduced and mixes with the return air. The outdoor air can be mixed with the return air either in the ductwork prior to the air-conditioning or heat pump unit or at the unit's mixing plenum. In either case, the

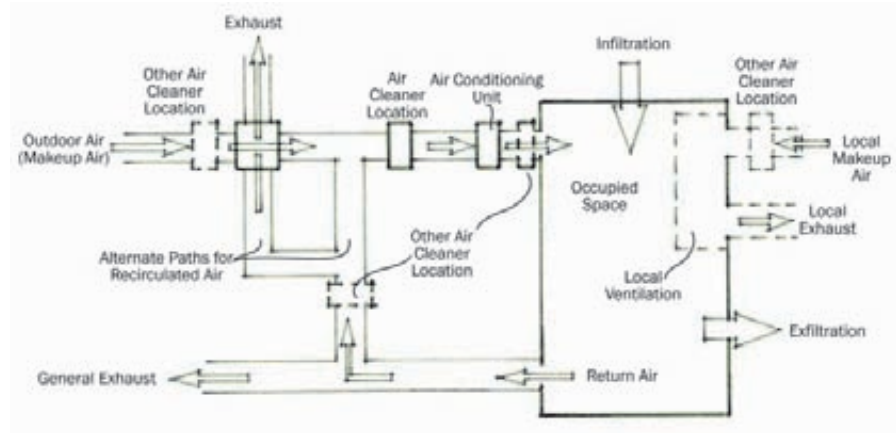

**Figure 4-31.** (HV7) Ventilation system.

damper and duct/plenum should be arranged to promote mixing and minimize stratification.

An air economizer mode can save energy by using outdoor air for cooling in lieu of mechanical cooling when the temperature of the outdoor air is low enough to meet the cooling needs. The system should be capable of modulating the outdoor air, return air, and relief air dampers to provide up to 100 percent of the design supply air quantity as outdoor air for cooling.

Systems should use a motorized outdoor air damper instead of a gravity damper to prevent outdoor air from entering during the unoccupied periods when the unit may recirculate air to maintain setback or setup temperatures. The motorized outdoor air damper for all climate zones should be closed during the full unoccupied period except where it may open in conjunction with an economizer cycle.

Demand control ventilation should be used in areas that have varying and high occupancy loads during the occupied periods to vary the amount of outdoor air in response to the need in a zone. The amount of outdoor air could be controlled by carbon dioxide sensors that measure the change in carbon dioxide levels in a zone relative to the levels in the outdoor air. A controller will operate the outdoor air, return air, and relief air dampers to maintain proper ventilation. See HV22, “Carbon Dioxide Sensors,” for more discussion on demand ventilation control.

See HV14, “Control Strategies,” for methods of operating the system efficiently.

## **HV8**

### ***Exhaust Air (Climate Zones: all)***

Central exhaust systems for toilet rooms, janitor closets, etc., should be interlocked to operate with the air-conditioning or heat pump unit except during unoccupied periods. These exhaust systems should have a motorized damper that opens and closes with the operation of the fan. The damper should be located as close as possible to the duct penetration of the building envelope to minimize conductive heat transfer through the duct wall and avoid having to insulate the duct. During unoccupied periods, the damper should remain closed, even while the air conditioning or heat pump unit is operating, to maintain setback or setup temperatures.

**HV9 Ductwork Distribution (Climate Zones: all)**

Air should be ducted through low pressure (system pressure classification of less than 2 in.) rigid ductwork. Supply and return air should be ducted to supply diffusers and return registers in each individual space. The ductwork should be as direct as possible, minimizing the number of elbows, abrupt contractions and expansions, and transitions. Long radius elbows and 45-degree lateral take-offs should be used wherever possible. Where variable air volume systems are used, they should have single-duct air terminal units to control the volume of air to the zone based on the space temperature sensor.

In general, the following sizing criteria should be used for the duct system components:

1. Diffusers and registers should be sized with a static pressure drop no greater than 0.08 in.
2. Supply and return ductwork should be sized with a pressure drop no greater than 0.08 in. per 100 linear feet of duct run.

Flexible ductwork should be of the insulated type and should be

1. limited to connections between duct branch and diffusers,
2. limited to connections between duct branch and variable air volume terminal units,
3. limited to 5 ft or less,
4. installed without any kinks, and
5. installed with a durable elbow support when used as an elbow.

Ductwork should not be installed outside the building envelope in order to minimize heat gain to, or heat loss from, the ductwork due to outdoor air temperatures and solar heat gain. Ductwork on rooftop units should enter or leave the air-conditioning or heat pump unit through an insulated roof curb around the perimeter of the air-conditioning or heat pump unit's footprint.

Duct static pressures should be designed, and equipment and diffuser selections should be selected, to not exceed the noise criteria for the space. See HV19, "Noise Control," for additional information.

**HV10 Duct Insulation (Climate Zones: all)**

All supply air ductwork should be insulated. All return air ductwork located above the ceiling immediately below the roof should be insulated. Any outdoor air ductwork should be insulated. All exhaust and relief air ductwork between the motor-operated damper and penetration of the building exterior should be insulated. Include a vapor retardant on the outside of the insulation where condensation is possible.

**Exception:** In conditioned spaces without a finished ceiling, only the supply air duct mains and major branches should be insulated. Individual branches and runouts to diffusers in the space being served do not need to be insulated, except where it may be necessary to prevent condensation.

**HV11 Duct Sealing and Leakage (Climate Zones: all)**

The ductwork should be sealed for Seal Class B and leak tested at the rated pressure. The leakage should not exceed the allowable CFM/100 ft<sup>2</sup> of duct area for the seal and leakage class of the system's air quantity apportioned to each section tested. See HV15, "Testing, Adjusting, and Balancing," for guidance on ensuring system performance.

**HV12 Fan Motors (Climate Zones: all)**

Motors for fans 1 horsepower or greater should meet NEMA premium efficiency motor guidelines when available as an option (see [www.nema.org](http://www.nema.org)).

**HV13 Thermal Zones (Climate Zones: all)**

Office buildings should be divided into thermal zones based on building size, part-load performance requirements, space layout and function, number of tenants, and the needs of the user. In an office building with similar internal loads throughout, a minimum of one zone for each of the perimeter exposures, one for the top floor building core area, one for the bottom floor building core area, and one for the interior would be ideal; for small buildings, this may be impractical. Zoning can also be accomplished using multiple air-handling units or by having multiple zone control with a single air-handling unit. The temperature sensor for a zone should be located in a room representative of that entire zone.

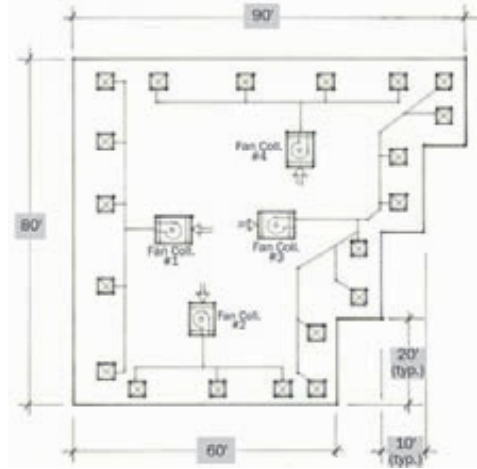

**Figure 4-32.** (HV13) Perimeter system zoning.

**HV14 Control Strategies (Climate Zones: all)**

The use of control strategies can help to reduce energy. Time-of-day scheduling is useful when it is known which portions of the building will have reduced occupancy. Control of the ventilation air system can be tied into this control strategy. Having a setback temperature for unoccupied periods during the heating season or setup temperature during the cooling season will help to save the energy required to heat up or cool down large masses within the building. A pre-occupancy operation period will help to purge the building of contaminants that build up overnight from the outgassing of products.

**HV15 Testing, Adjusting, and Balancing (TAB) (Climate Zones: all)**

After the system has been installed, cleaned, and placed in continuous operation, the system should be tested, adjusted, and balanced for proper operation. This procedure will help to ensure that the correctly sized diffusers, registers, and grilles have been installed, each space receives the required airflow, the equipment meets the intended performance, and the controls operate as intended. The TAB subcontractor should certify that the instruments used in the measurement have been calibrated within 12 months prior to use. A written report should be submitted for inclusion in the Operation and Maintenance Manuals.

**Cautions**

**HV16 Heating Sources (Climate Zones: all)**

Forced air electric resistance and gas-fired heaters require a minimum airflow rate to operate safely. These systems, whether stand-alone or incorporated into an air-conditioning or heat pump unit, should include factory-installed controls to shut down the heater when there is inadequate airflow.

**HV17 Filters (Climate Zones: all)**

Air-conditioning and heat pump unit filters are included as part of the factory-assembled unit and will be selected by the equipment manufacturer, dependent on the airflow. Replacement of dirty filters should correspond to the filter manufacturer’s recommendations. Use a filter differential pressure gauge to monitor the pressure drop across the filters. The gauge should be checked on a routine basis as well as a visual inspection of the filters. Include a monitor to send an alarm when the filter pressure drop exceeds a predetermined maximum pressure drop.

**HV18 Return and Relief Air (Climate Zones: all)**

Relief (rather than return) fans should be used when necessary to maintain building pressurization during economizer operation. However, where return duct static pressure exceeds 0.5 in. of water, return fans should be used.

**HV19 Noise Control (Climate Zones: all)**

Acoustical requirements may necessitate attenuation of the supply and/or return air, but the impact on fan energy consumption should also be considered and, if possible, compensated for in other duct or fan components. Acoustical concerns may be particularly critical in short, direct runs of ductwork between the fan and supply or return outlet.

Avoid installation of the air-conditioning or heat pump units above occupied spaces. Consider locations above less critical spaces such as storage areas, toilet rooms, corridors, etc.

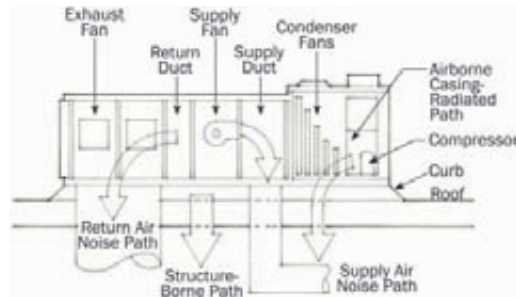

**Figure 4-33.** (HV19) Typical noise paths for rooftop-mounted HVAC units.

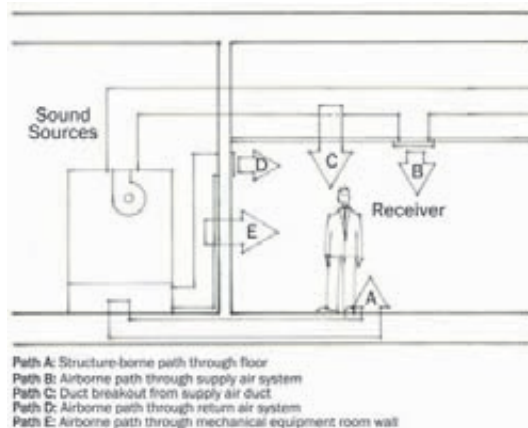

**Figure 4-34.** (HV19) Typical noise paths for interior-mounted HVAC units.

***HV20 Heating Supply Air Temperatures (Climate Zones: all)***

The heating supply air temperature of heat pump units is generally 90°F to 100°F. Ducts and supply registers should be selected to control air velocity and throw in order to minimize any perception of cool drafts.

***HV21 Zone Temperature Control (Climate Zones: all)***

The number of spaces on a zone, and the location of the temperature-sensing point, will affect the control of temperature in the various spaces of a zone. Locating the thermostat in one room of a zone with multiple spaces only provides feedback based on the conditions of that room. Locating a single thermostat in a large open area may provide a better response to the conditions of the zone with multiple spaces. Selecting the room or space that will best represent the thermal characteristics of the space due to both external and internal loads will provide the greatest comfort level.

Zone thermostats should not be mounted on an exterior wall to prevent misreading of the space temperature. Where this is unavoidable, use an insulated sub-base for the thermostat.

***HV22 Carbon Dioxide Sensors (Climate Zones: all)***

The number and location of carbon dioxide sensors for demand-control ventilation can affect the ability to accurately reflect the building or zone occupancy. A minimum of one CO<sub>2</sub> sensor per zone is recommended for systems with greater than 500 cfm of outdoor air. Multiple sensors may be necessary if the ventilation system serves spaces with significantly different occupancy expectations. Where multiple sensors are used, the ventilation should be based on the sensor recording the highest concentration of CO<sub>2</sub>.

Sensors used in individual spaces with high outdoor air requirements (e.g., conferences rooms) should be installed on a wall within the space; for multiple spaces of similar occupancy (i.e., private offices), a return air duct-mounted sensor may be more cost-effective and provide an average CO<sub>2</sub> measure for the zone. For sensors mounted in return air duct, adequate access for sensor calibration and field test must be provided. The number and location of sensors should take into account the sensor manufacturer's recommendations for their particular products.

The demand ventilation controls should maintain CO<sub>2</sub> concentrations less than or equal to 600 ppm plus the outdoor air CO<sub>2</sub> concentration in all spaces with CO<sub>2</sub> sensors. However, the outdoor air ventilation rate should not exceed the maximum design outdoor air ventilation rate required by code regardless of CO<sub>2</sub> concentration.

The outdoor air CO<sub>2</sub> concentration can be assumed to be 400 ppm without any direct measurement, or the CO<sub>2</sub> concentration can be monitored using a CO<sub>2</sub> sensor located near the position of the outdoor air intake.

CO<sub>2</sub> sensors should be certified by the manufacturer to have an accuracy of no less than 75 ppm, factory calibrated and calibrated periodically as recommended by the manufacturer.

***HV23 Economizers (Climate Zones: all)***

Economizers should be employed on air conditioners to help save energy by providing free cooling when ambient conditions are suitable to meet all or part of the space cooling load. Consider using enthalpy controls (vs. dry-bulb temperature controls) to help ensure that unwanted moisture is not introduced into the space in hot, humid climates.



## References

*ASHRAE Handbook—HVAC Applications*  
*ASHRAE Handbook—Fundamentals*  
*ASHRAE Handbook—HVAC Systems and Equipment*

## SERVICE WATER HEATING

---

### Good Design Practice

#### WH1 *Service Water Heating Types (Climate Zones: all)*

The service water heating equipment for this Guide considers the type of fuel source used for the HVAC heating system. This Guide does not cover systems that use oil, hot water, steam, or purchased steam for generating service water heating. The Guide also does not address the use of solar or site-recovered energy (including heat pump water heaters). These systems are alternative means that may be used to achieve 30 percent or greater savings over Standard 90.1-1999 and, where used, the basic principles of this Guide would apply.

The service water heating equipment included in this Guide for the HVAC options listed in HV2 (page 82) is:

1. Gas-fired water heater
2. Electric-resistance water heater

Both natural gas and propane fuel sources are available options for gas-fired units.

#### WH2 *System Description (Climate Zones: all)*

1. *Gas-Fired Storage Water Heater:* Forced-draft type water heater with a vertical or horizontal water storage tank. A thermostat controls the delivery of gas to the heater's burner. The heater requires a vent to exhaust the products of combustion.
2. *Gas-Fired Instantaneous Water Heater:* Atmospheric-type water heater with minimal water storage capacity. Control is generally by means of a flow switch that controls the burner and will have a modulating fuel valve that varies fuel flow as water flow changes. The heater requires a vent to exhaust the products of combustion. An electronic ignition is required to avoid the energy losses from a standing pilot.
3. *Electric Resistance Storage Water Heater:* Water heater consisting of a vertical or horizontal storage tank with one or more immersion heating elements. Thermostats controlling heating elements may be of the immersion or surface-mounted type.
4. *Electric Resistance Instantaneous Water Heater:* Compact, under-cabinet or wall-mounted type with insulated enclosure and minimal water storage capacity; a thermostat controls the heating element, which may be of the immersion or surface-mounted type. Instantaneous, point-of-use water heaters should provide water at a constant temperature regardless of input water temperature.

#### WH3 *Sizing (Climate Zones: all)*

The water heating system should be sized to meet the anticipated peak hot water load, typically about 0.4 gallons per hour per person in the average office building. The hot water demand will be higher if showers or other high-volume uses exist and these should be accounted for in sizing equipment. The supply water temperature should be no higher than 120°F to avoid injuries due to scalding.

**WH4**      **Equipment Efficiency (Climate Zones: all)**

Efficiency levels are provided in the guide for gas instantaneous, gas-fired storage, and electric resistance storage water heaters. For gas-fired instantaneous water heaters, the energy factor and thermal efficiency levels correspond to commonly available instantaneous water heaters without standing pilot lights.

The gas-fired storage water heater efficiency levels correspond to condensing storage water heaters. High-efficiency, condensing gas storage water heaters (energy factor > 0.90 or thermal efficiency > 0.90) are alternatives to the use of gas-fired instantaneous water heaters. The construction of a condensing water heater as well as the water heater venting must be compatible with the acidic nature of the condensate for safety reasons. Disposal of the condensate should be done in a manner compatible with local building code.

Efficiency metrics for high-efficiency electric storage water heaters (energy factors) are also provided for in this Guide. These efficiency metrics represent premium products that have reduced standby loss. The equation for energy factor shown in the climate zone recommendation tables corresponds to electric water heaters with the following Energy Factors:

Storage Volume	EF Requirement
30 gal	0.95
40 gal	0.94
50 gal	0.93
65 gal	0.91
75 gal	0.90
80 gal	0.89
120 gal	0.85

Instantaneous electric water heaters are an acceptable alternative to high-efficiency storage water heaters. Electric instantaneous water heaters are more efficient than electric storage water heaters, and point of use versions will minimize piping losses. However, their impact on building peak electric demand can be significant and should be taken into account during design. Where unusually high hot water loads (e.g., showers) are present during periods of peak electrical use, electric storage water heaters are recommended over electric instantaneous for those end uses.

**WH5**      **Location (Climate Zones: all)**

The water heater should be located close to the hot water fixtures to avoid the use of a hot water return loop or the use of heat tracing on the hot water supply piping. Where electric resistance heaters are used, point-of-use water heaters should be considered when there are a low number of fixtures or where they can eliminate the need for a recirculating loop.

**WH6**      **Pipe Insulation (Climate Zones: all)**

All service water heating piping should be installed in accordance with accepted industry standards. Insulation levels should be in accordance with the recommendation levels in chapter 3, and the insulation should be protected from damage. Include a vapor retardant on the outside of the insulation.

**References**

*ASHRAE Handbook—HVAC Applications.*

## BONUS SAVINGS

---

### Plug Loads

**PL1** *Additional Energy Savings from Efficient Appliances and Office Equipment (Climate Zones: all)*

Building owners and other users of this Guide can benefit from additional energy savings by outfitting offices with efficient appliances, office equipment, and other devices plugged into electric outlets. These “plug loads” can account for up to 25% of a small office building’s annual energy requirements and energy expense. In addition to their own energy requirements, plug loads also are a source of internal heat gains that increase air-conditioning energy use.

In office settings, personal computer networks are ubiquitous even in small office operations. Many facilities have significant numbers of personal computers, laptop computers, monitors, printers, and network servers. In addition, many offices are equipped with fax machines, copiers, and other electronic office gear. Offices may often have employee kitchens with refrigerators, microwave ovens, and coffee makers. Some will also have vending machines for cold soft drinks and snacks. Much of this equipment can operate or be on standby 24 hours per day year-round.

The following recommendations for purchase and operation of plug load equipment (Table 4-2) are an integral part of this Guide, but the energy savings from the plug load recommendations are expected to be in addition to the target 30% savings.

**PL2** *They Cost You More Than You Think (Climate Zones: all)*

Fortunately, there are cost-effective solutions for small office building owners and the design-build contractors who serve them. Plug load equipment that operates at high efficiency with minimal standby energy use is available from numerous manufacturers. Many makes and models of cord-connected devices are available with the Energy Star label that provide building owners with a means to minimize annual plug load operating costs. Equipment meeting Energy Star specifications—combined with built-in operational features—can cut plug load energy use by up to 25% over conventional devices. In most cases, any additional cost for a premium product is often recouped in a matter of months.

### Good Design Practice

**PL3** *Available Solutions (Climate Zones: all)*

To assist small office building owners and contractors capture these energy and cost savings, ASHRAE offers the following recommendations for purchase and operation of plug load equipment.

### References

[www.energystar.gov](http://www.energystar.gov)

**Table 4-2. Recommendations for Efficient Plug Load Equipment**

Equipment/Appliance Type	Purchase Recommendation	Operating Recommendation
Desktop computer	Energy Star only	Implement sleep mode software
Laptop computer – use where practical instead of desktops to minimize energy use	Energy Star only	Implement sleep mode software
Computer monitor	Energy Star flat screen monitors only	Implement sleep mode software
Printer	Energy Star only	Implement sleep mode software
Copy machine	Energy Star only	Implement sleep mode software
Fax machine	Energy Star only	Implement sleep mode software
Water cooler	Energy Star only	N/A
Refrigerator	Energy Star only	N/A

## Exterior Lighting

### Good Design Practice

#### *EL18 Exterior Lighting Power (Climate Zones: all)*

Limit exterior lighting power to 0.10 W/ft<sup>2</sup> for parking lot and grounds lighting. Calculate only for paved areas, excluding grounds that do not require lighting.

#### *EL19 Decorative Façade Lighting (Climate Zones: all)*

Avoid the use of decorative façade lighting. This does not include lighting of walkways or entry areas of the building that may also light the building itself.

#### *EL20 Sources (Climate Zones: all)*

- All general lighting luminaires should utilize pulse-start metal halide or fluorescent or compact fluorescent amalgam lamps with electronic ballasts.
- Standard high-pressure sodium lamps are not recommended due to their reduced visibility and poor color-rendering characteristics.
- Incandescent lamps are only recommended when used on occupancy sensors for lights that are normally off.

### Cautions

#### *EL21 (Climate Zones: all)*

Parking lot lighting locations should be coordinated with landscape plantings so that tree growth does not block effective lighting from pole-mounted luminaires.

#### *EL22 (Climate Zones: all)*

Parking lot lighting should not be significantly brighter than lighting of the adjacent street. Follow IESNA RP-33-1999 recommendations for uniformity and illuminance recommendations.

**EL23 (Climate Zones: all)**

For parking lot and grounds lighting, do not increase luminaire wattage in order to use fewer lights and poles. Increased contrast makes it harder to see at night beyond the immediate fixture location. Flood lights and wall-packs should not be used, as they cause hazardous glare and unwanted light encroachment on neighboring properties. Limit lighting in parking and drive areas to not more than 250-watt pulse-start metal halide lamps at a maximum 25 ft mounting height in urban and suburban areas. Limit to 175 watts in rural areas. Use cut-off luminaires that provide all light below the horizontal plane and help eliminate light trespass.

**EL24 (Climate Zones: all)**

Use photocell or astronomical time switch on all exterior lighting. If a building energy management system is being used to control and monitor mechanical and electrical energy use, it can also be used to schedule and manage outdoor lighting energy use. Turn off exterior lighting not designated for security purposes when the building is unoccupied.

**EL25 (Climate Zones: all)**

For colder climates, fluorescent and CFL luminaires must be specified with cold temperature ballasts. Use CFL amalgam lamps.

**References**

IESNA Recommended Practices and Design Guidelines, RP-20-1998, RP-33-99, DG-5-94, and G-1-03 available from IESNA at [IESNA.org](http://IESNA.org)  
RPI *Outdoor Lighting Pattern Book* available at [IESNA.org](http://IESNA.org)



# Appendix A

# Envelope Thermal Performance Factors

The climate zone tables present the opaque envelope recommendations in a standard format. This is a simple approach, but it limits the construction options. In order to allow for alternative constructions, the recommendations can also be represented by thermal performance factors such as U-factors for above-grade components, C-factors for below-grade walls, or F-factors for slabs-on-grade; see Table A-1. Any alternative construction that is less than or equal to these thermal performance factors will be acceptable alternatives to the recommendations.

**Table A-1. Envelope Thermal Performance Factors**

Item	Description	Unit	#1	#2	#3	#4	#5	#6	
Roof	Insulation entirely above deck	R	15	20	30				
		U	0.063	0.048	0.032				
	Metal building	R	19	13+13	13+19				
		U	0.065	0.055	0.049				
	Attic and other	R	30	38	60				
		U	0.034	0.027	0.017				
	Single rafter	R	30	38	38+5	38+10			
		U	0.360	0.028	0.024	0.022			
	Walls, Above Grade	Mass	R	5.7	7.6	9.5	11.4	15.2	
			U	0.151	0.123	0.104	0.090	0.071	
Metal building		R	13	13+13	13+16				
		U	0.113	0.057	0.055				
Steel framed		R	13	13+3.8	13+7.5	13+22			
		U	0.124	0.084	0.064	0.040			
Wood framed and other		R	13	13+3.8	13+7.5	13+10			
		U	0.089	0.064	0.051	0.045			
Below Grade	Below-grade walls	R	7.5	15					
		C	0.119	0.063					
Floors	Mass	R	4.2	6.3	8.3	10.4	12.5	16.7	
		U	0.137	0.107	0.087	0.074	0.064	0.051	
	Steel joist	R	19	30	38				
		U	0.052	0.038	0.032				
	Wood framed and other	R	19	30					
		U	0.051	0.033					
Slabs	Unheated	R-in	10-24	15-24	20-24				
		F	0.540	0.520	0.51				
	Heated	R-in	7.5-12	7.5-24	10-36	15 Full	20 Full		
		F	0.60	0.56	0.51	0.30	0.261		



**Errata for**  
***Advanced Energy Design Guide for Small Office Buildings***  
**October 5, 2006**

Page 58: The caption for Figure 4-1 is incorrect. Instead of “(a) concrete, (b) wood, or (c) metal” it should read “(a) concrete, (b) metal, or (c) wood.” The corrected figure is provided below.

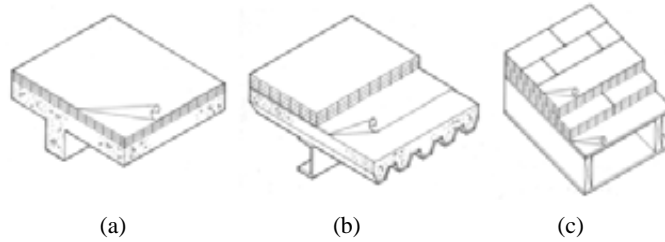

**Figure 4-1.** (EN2) Insulation entirely above deck. Insulation is installed above (a) concrete, (b) metal, or (c) wood deck in a continuous manner.

**Errata for**  
***Advanced Energy Design Guide for Small Office Buildings***  
**November 8, 2006**

Page 5: The horizontal axes for the bar graphs in Figures 2-2 and 2-3 are labeled incorrectly. Instead of “Annual Energy Use (kBtu)” they should read “Annual Energy Use (MBtu).” The corrected figures are provided below.

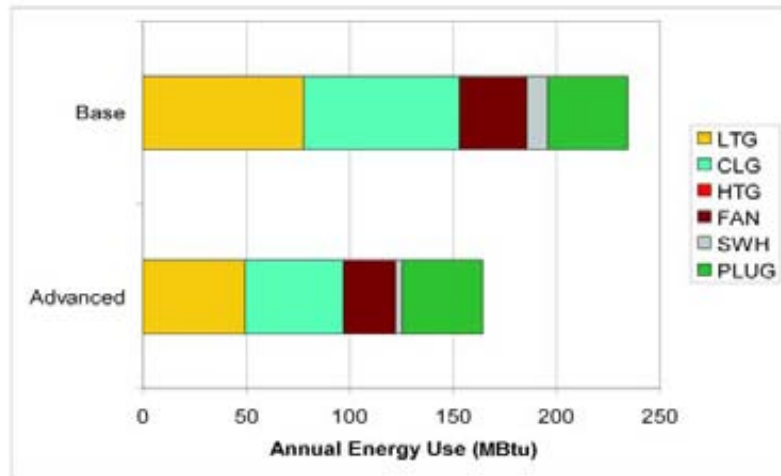

**Figure 2-2.** Estimated annual energy use for lighting, heating, cooling, fans, service water heating, and plug loads for a 5,000 ft<sup>2</sup> small office building in a cooling-dominated climate (Miami). The baseline energy use is for a 90.1-1999 compliant building, and the advanced energy use is for a building compliant with the recommendations of this Guide.

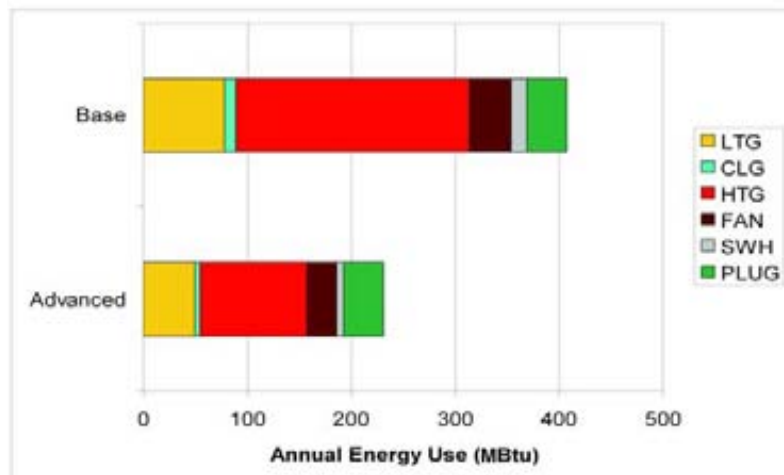

**Figure 2-3.** Estimated annual energy use for lighting, heating, cooling, fans, service water heating, and plug loads for a 5,000 ft<sup>2</sup> small office building in a heating-dominated climate (Duluth). The baseline energy use is for a 90.1-1999 compliant building, and the advanced energy use is for a building compliant with the recommendations of this Guide.