



# Textile Chemical Processing

Students Handbook + Practical Manual

Class XII



**CENTRAL BOARD OF SECONDARY EDUCATION**  
Shiksha Kendra, 2, Community Centre, Preet Vihar, Delhi-110301

*In collaboration with*



National Institute of Fashion Technology





Textile Chemical Processing

Students Handbook + Practical Manual Class XII

PRICE : ₹ 140/-

FIRST EDITION : 2014

© CBSE, India

COPIES : 1,000

No Part of this publication may be reproduced, stored in a retrieval system or transmitted, in any form or by any means, electronic, mechanical photocopying, recording or otherwise without the prior permission of the publisher.

**PUBLISHED BY** : The Secretary, Central Board of Secondary Education,  
Shiksha Kendra, 2, Community Centre, Preet Vihar,  
Delhi - 110301

**DESIGNED & LAYOUT** : M/s. India Offset Press, A-1, Mayapuri Industrial Area, Phase-1,  
New Delhi - 110064

**PRINTED BY** : Dee Kay Printers 5/37A Kirti Nagar Indl. Area, New Delhi - 110015  
Phone: 25938138, 25414260



## भारत का संविधान

### उद्देशिका

हम भारत के लोग भारत को एक [सम्पूर्ण प्रभुत्व—संपन्न समाजवादी पंथनिरपेक्ष लोकतंत्रात्मक गणराज्य] बनाने के लिए, तथा उसके समस्त नागरिकों को :

सामाजिक, आर्थिक और राजनैतिक न्याय,  
विचार, अभिव्यक्ति, विश्वास, धर्म

और उपासना की स्वतंत्रता,  
प्रतिष्ठा और अवसर की समता

प्राप्त कराने के लिए तथा उन सब में व्यक्ति की गरिमा और राष्ट्र की एकता और अखण्डता सुनिश्चित करने वाली बंधुता बढ़ाने के लिए दृढसंकल्प होकर अपनी इस संविधान सभा में आज तारीख 26 नवम्बर, 1949 ई. को एतद्द्वारा इस संविधान को अंगीकृत, अधिनियमित और आत्मार्पित करते हैं।

1. संविधान (बयालिसवां संशोधन) अधिनियम, 1976 की धारा 2 द्वारा (3.1.1977) से "प्रभुत्व—संपन्न लोकतंत्रात्मक गणराज्य" के स्थान पर प्रतिस्थापित।
2. संविधान (बयालिसवां संशोधन) अधिनियम, 1976 की धारा 2 द्वारा (3.1.1977 से), "राष्ट्र की एकता" के स्थान पर प्रतिस्थापित।

### भाग 4 क मूल कर्तव्य

51 क. मूल कर्तव्य — भारत के प्रत्येक नागरिक का यह कर्तव्य होगा कि वह —

- (क) संविधान का पालन करे और उसके आदर्शों, संस्थाओं, राष्ट्रध्वज और राष्ट्रगान का आदर करे;
- (ख) स्वतंत्रता के लिए हमारे राष्ट्रीय आंदोलन को प्रेरित करने वाले उच्च आदर्शों को हृदय में संजोए रखे और उनका पालन करे;
- (ग) भारत की प्रभुता, एकता और अखंडता की रक्षा करे और उसे अक्षुण्ण रखे;
- (घ) देश की रक्षा करे और आह्वान किए जाने पर राष्ट्र की सेवा करे;
- (ङ) भारत के सभी लोगों में समरसता और समान भ्रातृत्व की भावना का निर्माण करे जो धर्म, भाषा और प्रदेश या वर्ग पर आधारित सभी भेदभाव से परे हों, ऐसी प्रथाओं का त्याग करे जो स्त्रियों के सम्मान के विरुद्ध हैं;
- (च) हमारी सामासिक संस्कृति की गौरवशाली परंपरा का महत्त्व समझे और उसका परिरक्षण करे;
- (छ) प्राकृतिक पर्यावरण की जिसके अंतर्गत वन, झील, नदी, और वन्य जीव हैं, रक्षा करे और उसका संवर्धन करे तथा प्राणिमात्र के प्रति दयाभाव रखे;
- (ज) वैज्ञानिक दृष्टिकोण, मानववाद और ज्ञानार्जन तथा सुधार की भावना का विकास करे;
- (झ) सार्वजनिक संपत्ति को सुरक्षित रखे और हिंसा से दूर रहे;
- (ञ) व्यक्तिगत और सामूहिक गतिविधियों के सभी क्षेत्रों में उत्कर्ष की ओर बढ़ने का सतत प्रयास करे जिससे राष्ट्र निरंतर बढ़ते हुए प्रयत्न और उपलब्धि की नई उंचाइयों को छू ले।

# THE CONSTITUTION OF INDIA

## PREAMBLE

**WE, THE PEOPLE OF INDIA**, having solemnly resolved to constitute India into a **SOVEIGN SOCIALIST SECULAR DEMOCRATIC REPUBLIC** and to secure to all its citizens:

**JUSTICE**, Social Economic and political;

**LIBERTY** of thought, expression, belief, faith and worship;

**EQUALITY** of status and of opportunity; and to promote among them all;

**FRATERNITY** assuring the dignity of the individual and the [unity and integrity of the Nation];

**IN OUR CONSTITUENT ASSEMBLY** this twenty-sixth day of November, 1949, do **HEREBY ADOPT ENACT AND GIVE TO OURSELVES THIS CONSTITUTION.**

1. Subs, by the Constitution (Forty-Second Amendment) Act. 1976, sec. 2, for "Sovereign Democratic Republic (w.e.f. 3.1.1977)
2. Subs, by the Constitution (Forty-Second Amendment) Act. 1976, sec. 2, for "unity of the Nation (w.e.f. 3.1.1977)

# THE CONSTITUTION OF INDIA

## Chapter IV A

### Fundamental Duties

#### ARTICLE 51A

#### **Fundamental Duties - It shall be the duty of every citizen of India-**

- (a) to abide by the Constitution and respect its ideals and institutions, the National Flag and the National Anthem;
- (b) to cherish and follow the noble ideals which inspired our national struggle for freedom;
- (c) to uphold and protect the sovereignty, unity and integrity of India;
- (d) to defend the country and render national service when called upon to do so;
- (e) to promote harmony and the spirit of common brotherhood amongst all the people of India transcending religious, linguistic and regional or sectional diversities; to renounce practices derogatory to the dignity of women;
- (f) to value and preserve the rich heritage of our composite culture;
- (g) to protect and improve the natural environment including forests, lakes, rivers, wild life and to have compassion for living creatures;
- (h) to develop the scientific temper, humanism and the spirit of inquiry and reform;
- (i) to safeguard public property and to abjure violence;
- (j) to strive towards excellence in all spheres of individual and collective activity so that the nation constantly rises to higher levels of endeavour and achievement.



# Preface

*W*e take the opportunity to present this standard handbook entitled as "Textile Chemical Processing" to the students of Class XII of CBSE Vocational course. The objective of this book is to present the subject matter in most concise, compact, to the point and lucid manner.

While writing this book, the requirements, of all the students regarding understanding of terminology used in the Industries were constantly kept in the mind.

To make it more useful, the book has been written in an easy language and special care has been taken to explain all the terminology in simple manner. I hope that the book will fulfill the requirement of the students, for which it has been designed.

The Faculty of the National Institute of Fashion Technology has developed the curriculum and the learning Material. I place on record the Board's thankful acknowledgement of the services rendered by Shri P.K. Gera, Director General, NIFT, Sr. Prof Banhi Jha, Dean-Academics, Project In-charge and Ms. Savita Sheoran Rana, Chairperson, Textile Design Department, Project Anchor - Textile Design. The course is developed and prepared by faculty members from across the NIFT centers. CBSE also acknowledges the contribution by Prof. Kripal Mathur, Prof. V. Shivalingam, Director, NIFT Bangaluru, Prof. Sudha Dhingra, NIFT New Delhi, Ms. Savita Sheoran Rana, Associate Prof. & Chairperson, NIFT New Delhi, Mr. Manish Bhargava, Associate Prof., Gandhinagar and Ms. Ruby Kashyup Sood, Associate Prof, NIFT New Delhi . The Board also acknowledges the co-ordination and guidance provided by Dr. Biswajit Saha, Additional Director and Ms Swati Gupta, Deputy Director (Vocational Education).

Although every care has been taken to check mistakes and misprints, in case there has been any omission or error kindly bring it to our notice. Your suggestions will be incorporated in the next edition.

**Vineet Joshi**  
Chairman, CBSE



# Acknowledgements

## Preamble

Textile Chemical Processing provide the complete basic understanding of the fabrics processing of all type of fabrics which are used into Apparel or Home fashion Industry. It includes Pre-treatments, Dyeing, Printing and Finishing of fabrics

In order to develop knowledge of value addition on fabric, "Textile Chemical Processing" course is introduced as an elementary course. The course will provide an overview of textile chemical processing in the Textile mills. The overall objective of this course is to provide the fundamental understanding of basic process used in the industry to improve the feel, appearance and quality of fabrics

## CBSE

**Mr. Vineet Joshi, IAS, Chairman**

**Sh. M.V.V. Prasada Rao, Director  
Voc & Edusat.**

**Dr. Biswajit Saha, Additional Director,  
Vocational Education.**

**Ms Swati Gupta, Deputy Director,  
Vocational Education, CBSE Anchor.**

## NIFT

**Mr. Prem Kumar Gera, IAS, D.G.**

**Sr. Prof. Banhi Jha, Dean (A).**

**Prof. Kripal Mathur, Registrar,  
NIFT- H.O.**

## Anchor

**Ms. Savita Sheoran Rana, Chairperson, Textile Design Department, NIFT Delhi.**

## Contributors

- **Prof. V. Sivalingam, Director NIFT- Bangaluru**
- **Mr. Manish Bhargava, Associate Professor, Textile Design Department,  
NIFT, Gandhinagar.**





## INDEX

|   |           |
|---|-----------|
| <b>UNIT - I : TEXTILE CHEMICAL PROCESSING</b>                           | <b>1</b>  |
| 1.1 Textile Chemical Processing for the Fibres (Preparatory Operations) | 1         |
| 1.2 Singeing  | 2         |
| 1.3 De-Sizing   | 3         |
| 1.4 Scouring  | 3         |
| 1.5 Bleaching   | 4         |
| 1.6 Mercerization   | 5         |
| <b>UNIT - II : TEXTILE DYEING</b>                                       | <b>7</b>  |
| 2.1 Colouring Materials   | 7         |
| 2.2 Important Features of Dyes  | 8         |
| 2.2.1 Vat Dyes  | 8         |
| 2.2.2 Azoic/Naphthol Dyes   | 9         |
| 2.2.3 Direct Dyes   | 10        |
| 2.2.4 Sulfur Dyes   | 10        |
| 2.2.5 Reactive Dyes   | 12        |
| 2.2.6 Disperse Dyes   | 13        |
| 2.2.7 Basic Dyes  | 13        |
| 2.2.8 Acid Dyes   | 14        |
| 2.2.9 Chrome / Mordant / Metallic Dyes                                  | 14        |
| 2.3 The Selection of Dyes   | 15        |
| 2.4 Dyeing Objectives   | 15        |
| 2.5 Dyeing Methods  | 15        |
| 2.6 Batch Dyeing Processes  | 16        |
| 2.7 Continuous Dyeing Processes   | 17        |
| 2.8 Semi Continuous Dyeing Processes                                    | 19        |
| 2.9 Styles of Dyeing  | 34        |
| <b>UNIT III : TEXTILE PRINTING</b>                                      | <b>39</b> |
| 3.1 Stencil Printing  | 42        |
| 3.2 Block Printing  | 42        |
| 3.3 Hand Screen-Printing  | 43        |
| 3.4 Automatic Flat Bed Screen Printing                                  | 44        |
| 3.5 Rotary Screen Printing  | 45        |
| 3.6 Heat Transfer Printing  | 46        |



|      |                   |    |
|------|-------------------|----|
| 3.7  | Styles of Prints  | 47 |
| 3.8  | Direct Prints     | 47 |
| 3.9  | Discharge Prints  | 47 |
| 3.10 | Resist Prints     | 49 |
| 3.11 | Pigment Prints    | 49 |
| 3.12 | Blotch Prints     | 50 |
| 3.13 | Flock Printing    | 51 |
| 3.14 | Burn-Out Prints   | 52 |
| 3.15 | Duplex Prints     | 52 |
| 3.16 | Engineered Prints | 52 |
| 3.17 | Warp Prints       | 53 |

### **UNIT IV : TEXTILE FINISHES** **56**

|      |   |    |
|------|---|----|
| 4.1  | Classification of Finishes                            | 57 |
| 4.2  | According to Textile Chemists                         | 58 |
| 4.3  | According to Degree of Performance                    | 59 |
| 4.4  | General Finishes                                      | 59 |
| 4.5  | Napping / Brushing                                    | 62 |
| 4.6  | Emerizing, Sueding, Sanding or Peach Finish           | 63 |
| 4.7  | Parchmentising “Organdy”                              | 63 |
| 4.8  | Functional Finishes                                   | 63 |
| 4.9  | Shrinkage Control Methods                             | 69 |
| 4.10 | Soil Release / Stain Proof / Stain Repellent Finishes | 71 |
| 4.11 | Water Repellent / Water Proof Finishes                | 71 |
| 4.12 | Anti Microbial Finishes                               | 72 |
| 4.13 | Insect & Moth Control Finishes                        | 73 |
| 4.14 | Durable Flame Retardant                               | 73 |
| 4.15 | Fabric and Garment Washes                             | 74 |
| 4.16 | Micro Encapsulated Finishes                           | 75 |

### **Glossary** **78**







## UNIT I

### TEXTILE CHEMICAL PROCESSING

#### Learning Outcome

After finishing this unit, students will be able to understand –

- Various technical terminology used in the industry.
- Various types of impurities presents in the substrates.
- The processes involved in removing impurities.

#### Overview

In this chapter students will get to know about various techniques of preparatory process of textile material which is the essential part of the processing. Without preparatory process it is very difficult to achieve the desire result in the dyeing , printing and finishing process.

After studying this chapter, the students will be familiarized and will be able to understand terminology used in the Industry, impurities present in natural and synthetic fibers (Raw Cotton, Wool, Silk, Polyester, Nylon and Acrylic) and their effective and cost economic removal.

This unit also deals with Chemical Processes, Chemical Treatment , Process Flowcharts of Cotton, Wool, Silk and Synthetic fibers, Elementary Knowledge of Sizing, Desizing, Scouring & Bleaching. After understanding these terminology students will be able to know the processes involved in achieving desired fabric quality.

#### Introduction To Chemical Processing : Pre-treatments

##### 1.1 Textile Chemical Processing for the Fibres (Preparatory Operations)

The fabric collected from various weaving setups, can not be used directly for manufacturing various textile products. There are number of impurities present in the fabric such as dust, dirt, oil stains, oil and waxes, starches or other sizing materials, seed particles, and natural coloring materials. These impurities can be classified as.

- I. Natural Impurities &
- II. Added Impurities



**Natural Impurities** :- Natural impurities are generally presents in the natural fibres in the form of oil, waxes, natural colour, vegetable matters ( such as leaves particles, Seed particles, etc), Dust particle. In case of wool sweat is also considered as impurities which is deposited on the sheep's or goat's hair.

**Added Impurities**:- These type of impurities are manually added to the yarn or fibres during the manufacturing process to increase the efficiency of the weaving process such as, Sizing materials (which includes starches, or polyvinyl alcohol are applied on the surfaces of the yarn to reduces the breakage of yarn during the weaving operation and increase the weaving efficacy.) Spin finishes are another example of the added impurities. This type of impurities are generally added to synthetic yarns which contains Antistatic agents and Lubricants. which reduces the statics charge buildup and friction during the weaving operation.

These impurities make fabric hydrophobic in nature and limit the fabric for further processing.

The main objectives of preparatory treatments of textile materials are,

- To remove all the impurities, both naturals and those added during production that may interfere in subsequent dyeing or finishing process.
- Improve the ability of the fibers to absorb water, dyes solutions and chemicals.
- Impart proper brightness or whiteness to fabrics according to need, especially when brilliant or pastel shades are desired.

All of these impurities can not be removed by a single operations. It requires sequences of operations, which is called Processing. All the operations before the dyeing of fabrics are called Preparatory Process or Pretreatments. These pretreatments includes Singeing, Desizing, Scouring, Souring, Bleaching and Mercerizing. All of these Operations have the specific objectives and it is not necessary to use all the operation to all the fabrics. It generally depends on the type of fabrics, contains of the fabric and the end uses of the fabric.

### 1.2 Singeing

During the weaving operations, warp yarns pass though heild wires, and reed. It is continuously under friction during weaving process. Due to continuous friction, yarn develops hairiness. This hairiness is undesirable in the fabric and provides an unpleasant feel to the fabric or garment.

The main objective of the Singeing is removal of protruding fibers from both sides of fabric. For this purpose, the fabric is passed through singeing Machine in open width,





flat and under tension. Fabric is passed over an open flame at a high speed (300 yards/min) to prevent scorching. Uneven singeing leads to unlevelled dyeing.

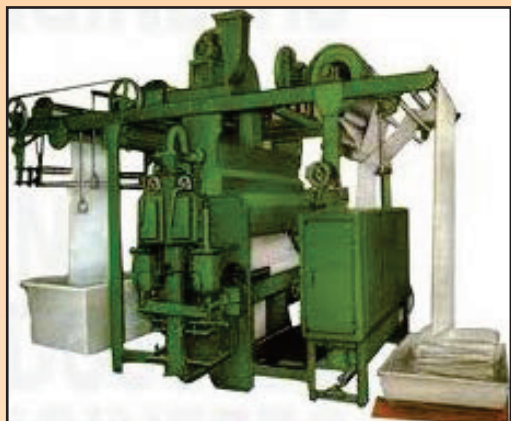

*Pic. 1.1: Plate Singeing Machine*



*Pic. 1.2: Singeing Machine*

### 1.3 De-sizing

Size are added during the weaving preparatory process. Main objective of the sizing is to provide strength to the yarn. This improves the weaving efficiency by reducing the yarn breakage. After the weaving is completed, the size material is undesirable in the fabric and it makes the fabric stiff and hydrophobic in nature. The main objective of the De-sizing is removal of starch from fabric. For this purpose, the fabric is impregnated in the de-sizing bath and stored for 8-12 hrs. The Impregnating bath contains required amount of enzyme, Wetting agent and Sodium Chloride (NaCl). After this process, fabric is thoroughly washed with hot water.

In Enzyme application of De-sizing, the fabric padded with enzyme bath is then passed through steam of 96-100°C temp. This is a rapid process in which De-sizing process complete in less than one minute. The main advantage of De-sizing with enzymes is that there is no risk of damaging the fibres. The process is an eco- friendly and relatively expensive.

### 1.4 Scouring

The yarn made of natural fibres contains natural oils and waxes. These oils and waxes make fabric hydrophobic and do not allow dyes and chemicals to penetrate into the fibre. The Scouring is a cleaning treatment in which oil, waxes and residual sizes are removed from the fabric by the chemicals. After scouring the fabric becomes absorbent in nature.

In this process, fabric is treated with strong alkali solution (5-10 gm/lit NaOH or mixture of NaOH & Sodium Carbonate) close to or above the boiling temp. for 1-2 hours with hot



rinse and final cold rinse with acetic acid. The final rinse with acetic acid is also called souring process.

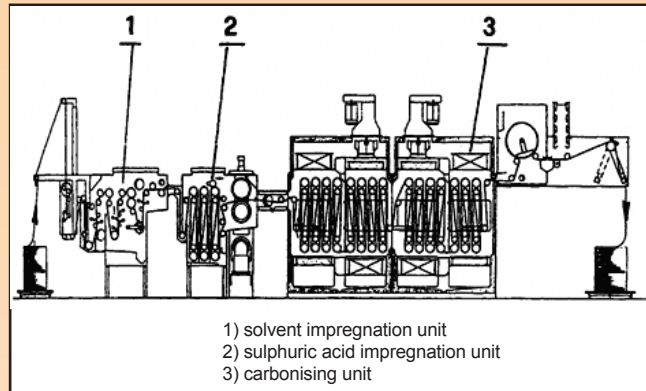

*Pic. 1.3: De-sizing & Scouring Machine*



*Pic. 1.4: De-sizing & Scouring fabric*

### 1.5 Bleaching

After scouring process, the fabric is free from oils and waxes, however natural colouring matter are still present in the fibre. If this colour is not removed at this stage than it will be very difficult to attain the desired shade in dyeing process.

The main objective of the bleaching process is removal of natural coloring matter and to make the fabric perfect white with minimum damage to fibres and within the shortest possible time. Bleaching is generally carried out by oxidative process. Some of the example of the Bleaching agents are: Sodium hypo chlorite, Sodium chlorite and Hydrogen peroxide. Hydrogen peroxide is also called as “Universal bleaching agent”. Since, it is a very mild bleaching agent, It is used for almost all type of cotton, polyester/ cotton blends and silk fabrics.



*Pic. 1.5: Before Bleaching*



*Pic. 1.6: After Bleaching*





Peroxide bleaching is carried out generally near or above boiling temperature, under pressure, for one hour or more. After bleaching, the fabric is thoroughly rinsed with slight amount of basic solution to avoid formulation of insoluble salts of silicates.

After bleaching, fabric may be sold as perfect white cloth. For achieving perfect white cloth, fabric is treated with Optical whitening Agents, such as Tinopal , Ranipol etc and blueing agents such as Robin blue, Ujala etc.

### 1.6 Mercerization

Mercerization process was invented by John Mercer. He was a young chemist. One day, while he was filtering some chemical solution using cotton cloth, he observed some changes in the cotton fabrics. He studied the changes in detail to standardize the process.

In the Mercerization process, cotton fabric or yarn is treated with a cold concentrated solution of sodium hydroxide for one minute or less. In this process cotton fibers swell, untwist and their bean shaped cross section changes into a round form.

Mercerization improves the following properties of the cotton fabric.

- Strength would be increased to 15-25%.
- Enhanced luster.
- Greater affinity to water, dyes and other chemical finishes.
- Shrinkage control in both the direction of the fabric.

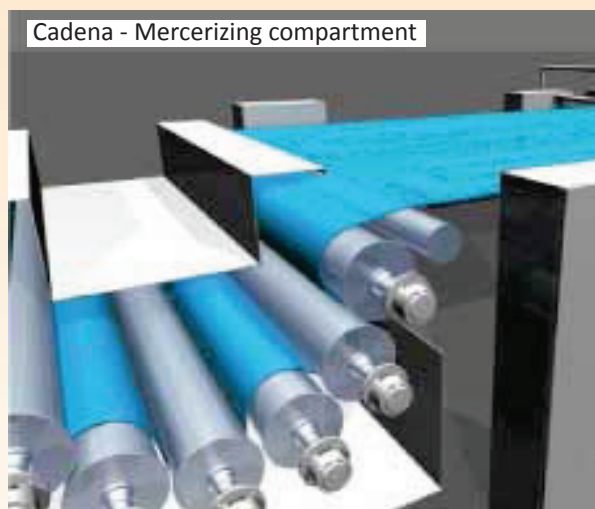

*Pic. 1.7: Fabric passing through Mercerization solution*

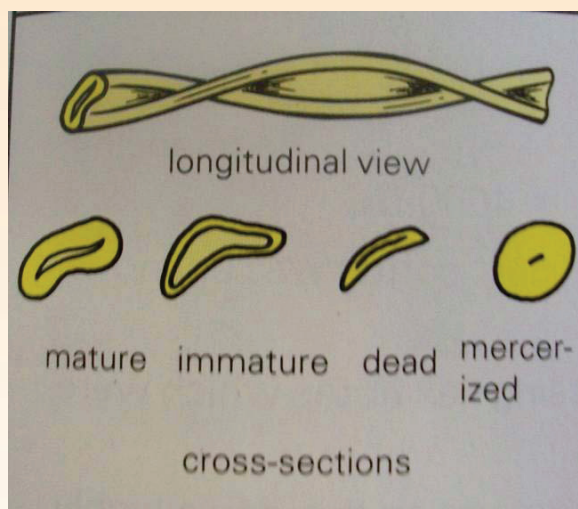

*Pic. 1.8 Cross Sectional changes in Cotton*



Fabric is padded with about 20-25% NaOH solution containing a wetting agent. Fabric is passed over several cans to allow a dwelling time of approximately one minute. During this time, NaOH will penetrate the fibres and react with them. At this stage the tension is applied lengthwise. The fabric is then placed on a “Stenter” machine and is pulled to its desired dimensions.

### Exercise

#### Fill in the blanks

1. Removal of protruding fibers from both sides of fabric is called as .....
2. Removal of starch from fabric is called as .....
3. .... treatment removes oil, waxes and residual sizes from the fabric.
4. Objective of the ..... process is to remove natural coloring matter to make perfect white fabric.
5. Hydrogen peroxide is also called as .....
6. The treatment of cotton fabrics or yarns with a cold concentrated solution of sodium hydroxide solution for one minute or less is called .....

#### Short answer questions

1. What are the chemicals used in De- Sizing?
2. What are the chemicals used in Scouring?
3. What are the chemicals used in Mercerizing?
4. What are the chemicals used in Bleaching?
5. What are the main objectives of preparation treatments?
6. What are the main objectives of De- Sizing?
7. What are the main objectives of Scouring process?
8. What are the main objectives of Bleaching process?
9. What are the main objectives of Mercerizing process?





## UNIT II

### TEXTILE DYEING

#### Learning Outcome

After finishing the unit, students will be able to –

- Dye all kind of textile fabrics.
- Select dyes as per the type of fabrics.
- Identify dyeing methods used in the industry.

#### Overview

In this unit students will gain knowledge about Dyes and Pigments, Suitability of Dyes for various kinds of fabrics, method of dyeing by important classes of dyes, important features of dyes and basic knowledge of dyeing technology. This chapter also describes various machines used in Dyeing.

After studying this unit, the students will be able to Dye all kind of textile fabrics, and get better understanding of roles of chemicals and auxiliaries in fabric dyeing.

#### 2.1 Colouring Materials

Fabric, you see in the daily life has various colours. These colors can be divided in to two category - Dyes and pigments. These dyes and pigments are used to impart color to the textile materials. In order to perform the coloring of the materials, dyes and pigments should have the following features.

| PIGMENTS   | DYES   |
|--|--|
| <i>Intense color, insoluble in water or &amp; Common solvents</i>  | <i>Intense color, must have solubility in water during dyeing stage</i>                    |
| <i>Are not made to have substantivity to fibers</i>                | <i>Must have substantivity to the fiber during dyeing stage.</i>                           |
| <i>Molecular size varies from small to large size</i>              | <i>Molecular size must be small enough to allow the molecules to penetrate the fibers.</i> |
| <i>Stable to further treatments in production &amp; normal use</i> | <i>Stable to further treatment in production and normal use.</i>                           |
| <i>Durability depends upon binders used</i>                        | <i>Able to acquire durability to wet treatments.</i>                                       |

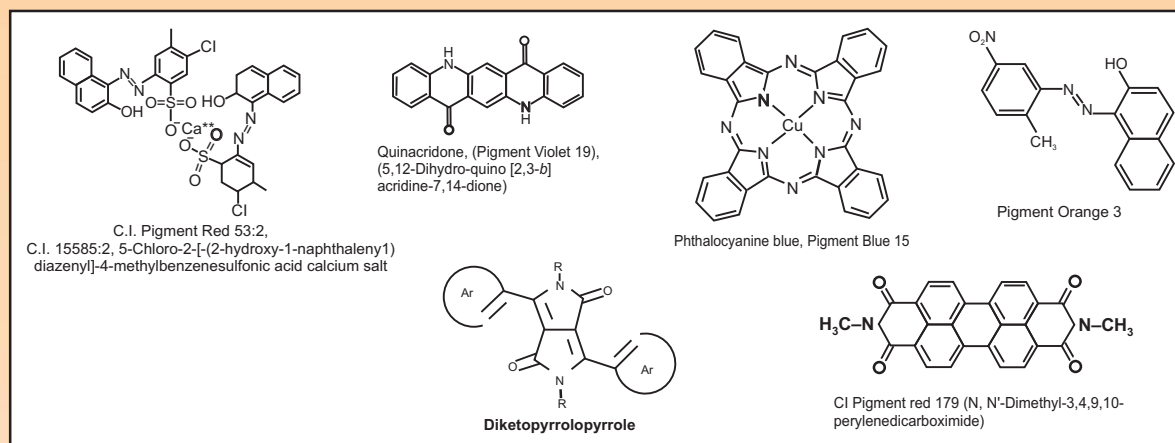

Pic.2.1 Structure of Dyes &amp; Pigments

## 2.2 Important Features of Dyes

There are various classes of dyes, which are having different fastness properties, affinity, towards fibres such as Direct dyes, Vat dyes, Reactive dyes, Sulphur dyes, Disperse dyes, Acid dyes and Metal complex dyes.

### 2.2.1 Vat Dyes

Vat dyes are insoluble organic compounds and do not have any substantivity to cellulose. These dyes are widely used for cellulose fibers and can also be used for protein and nylon fibers. They produce good color range but limited selection of orange, blue. Bright green are more popular in this class. Large amount of dyes are required to attain deeper shade.

#### Application

Since these dyes are insoluble in water, it can not be applied directly to the fabrics. First these dyes are converted into water soluble form, by reducing it with the help of Caustic soda and Sodium hydro sulphite.

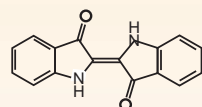

Indigo, (2, 2'-Bis  
(2, 3-dihydro-3-oxoindolylidene), Indigotin

Pic.2.3 Structure of  
Indigo Dye

When these dyes become soluble in water, they can be applied on a fabric.

After the application, these dyes are again converted into water insoluble form by oxidation process, with the use of hydrogen peroxide and acetic acid or simply by air oxidation.



Pic.2.2 Vat Dyes





These dyes are most difficult to process and require a skilled person to dye the fabric. Vat dyes have excellent fastness to crocking, perspiration, chlorine bleaching, oxidizing agents and high temperature treatments.

This is a very expensive dyeing process and high initial cost of dye and chemicals prevent it from uses in normal fabrics dyeing. Vat dyes are used on best quality of the fabrics where all round fastness is required. Indigo is the first known class of Natural Vat dye.

### 2.2.2 Azoic/Naphthol Dyes

Azoic Dyes are derived from aryl amides organic compounds. These chemical compounds can not be used directly as dyes. However, the dyes are formed inside the fibre by the reaction of primary Amines with Naphthols, under controlled conditions. Hence, these dyes are also called ingrain dyes. Azo group is generally present in this class of dyes, so it is also called Azo dyes.

These classes of dyes are also insoluble in water and primarily used for cellulose fibers. Some times these are used with triacetate to produce black shades;

These dyes produces full range of red , orange, brilliant yellow colour along with maroons, scarlet, deep black and burgundies. Azoic dyes lack green and bright blue colors.

#### Application

These dyes are applied in two stages; first stage is called Naphtholation of the fabric. In the second stage, the fabric is treated with soluble salt of primary amines, at cold condition, generally  $0^{\circ}\text{C} - 5^{\circ}\text{C}$ . Hence these dyes are also called Ice colour. Due to this, these dyes are the first choice of the dyers for Batik printing.

These dyes have good color fastness to washing and dry cleaning and poor to good fastness to light. Dark colors have poor fastness to crocking. Azoic Dyeing process is complex and time consuming.

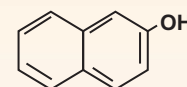

2 - Naphthol, Diazo Coupling Component

*Pic.2.4 Color & Structure of Azoic Dyes*



### 2.2.3 Direct Dyes

These dyes are derived from a formulation of Benzidine salts. These are water soluble dyes and least expensive one. These dyes are easy to apply and can be applied directly on the fabric, without any pretreatment. Dye fixing agents are not required to fix this category of dye. These dyes are widely used on cellulosic fibers.

Direct dyes are having wide range of colors and shades. The fabric dyed with the direct dyes generally does not have bright colors. Among the bright colors, only bright greens are available, but is more expensive than any other color.

#### Application

These are water soluble dyes; hence, can be directly applied on the fabric. These dyes have good color fastness to perspiration and dry cleaning. Light fastness of these dyes varies widely from poor to very good.



*Pic.2.5 Direct Dyes*

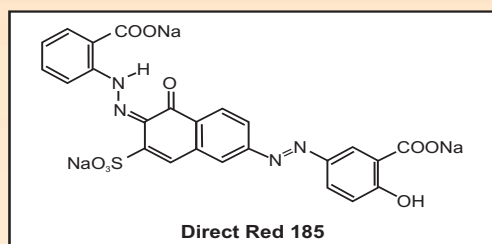

*Pic: 2.6 Direct Dye Structure*

Some direct dyes are metalized with copper to increase their light fastness. In other cases, copper salts are applied as an after treatment for improving light and wash fastness.

These dyes have poor fastness to washing and crocking. Majority of the direct dyes are used as back ground color for discharge printing.

### 2.2.4 Sulfur Dyes

These dyes are derived from the formulation of compounds containing sulfur. These are water insoluble dyes and applied by exhaust dyeing method. Sulfur dyes are widely used for cellulosic fibres for darker shades

#### Application

These are water insoluble dyes, and can not be applied on fabric directly. Sulfur dyes are made water soluble by reducing with Sodium Sulphite and sodium hydroxide. If dye are still insoluble than small amount of Sodium Hydro Sulphite is added with warm water. Once the dye becomes water soluble, it is applied by exhaust dyeing method.



After completion of dyeing, Sulfur dyes are again converted into water insoluble by oxidation process. These dyes are generally used for darker shades especially Navy blues, Jet black, Brown and Khakhi colors. These dyes are not having full spectrum of colors, true yellow color is not available in this dye category.

### Properties

Sulfur dyes are relatively easy to dye cellulosic fibre with good-to-excellent washes and lights fastness at a low cost. It produces a complete range of colors in “dull shade” and gives poor light fastness in pastel shades. These dyes are mainly used for dyeing black, brown, navy blue or olive, in medium to dark shades. Some yellows and blues shades are also available but there is only one red and a green dye.

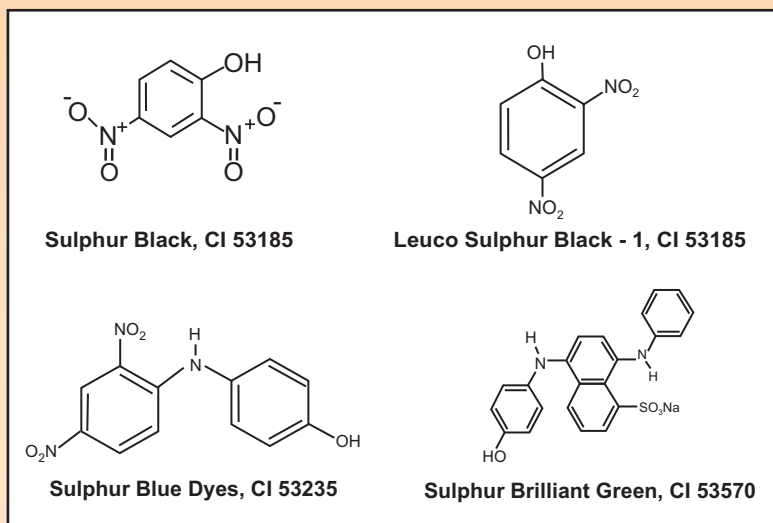

*Pic.2.6 Structure of Sulfur Dyes*



*Pic.2.7:Color of Sulfur Dyes*

Sometimes, these dyes are also used for improving the wash fastness of the Direct dyed fabric called topping.

Sulfur dyes are having good fastness to light, washing, dry cleaning and perspiration. However, these dyes have poor fastness to chlorine bleach. Sulfur dyed materials can not be stored for longer periods at higher than normal room temperature because in presence of moisture, It tends to oxidize and form sulfuric acids, and then this acid cause tendering to cellulose fabric. Due to this tendering process, sometimes the color of the fabric also changes and become dull. This is called bronziness of the shade.



### 2.2.5 Reactive Dyes

Reactive dyes are water soluble dyes, which are anionic in nature. Since these type of dyes react with fibers and make covalent type of bonding with the fiber, hence they are called Reactive dyes. These dyes can be classified as hot brand reactive dyes and cold brand dyes.

Procion (Triazine type)-H, is a hot type of reactive dye and it react with cellulose in presence of sodium carbonate at the temperature range of 75-90°C. Procion-C is cold type of reactive dyes, reacts at room temperature in presence of sodium carbonate.

Ramazol is another type of reactive dyes (Vinyl sulfone reactive dye) and react in presence of base and under goes elimination reaction to form vinyl-sulfone group, which then combines with cellulose and make bonding. It is a time consuming process.

These dyes are primarily used for cotton and other cellulose fiber at an alkaline pH of 9-12. However, these dyes can also be used for wool, silk and polyamide fibers in weak acidic dye baths.

#### Application

Reactive dyes can be applied by exhaust method, as well as pad batch method also. Reactive dyes are available in complete range of colors. They are very bright in colors.

These dyes are having very good fastness to washing, Good-very good fastness to light, Good fastness to dry cleaning, perspiration, crocking and poor fastness to chlorine bleaching.

It is very easy to obtain level dyeing using reactive dyes. These dyes are having high flexibility in the choice of method of application of dyeing.

Cost of using reactive dyeing is high, because of price, loss of dyes during application and extensive washing. These dyes take excessive time for the dyeing process.

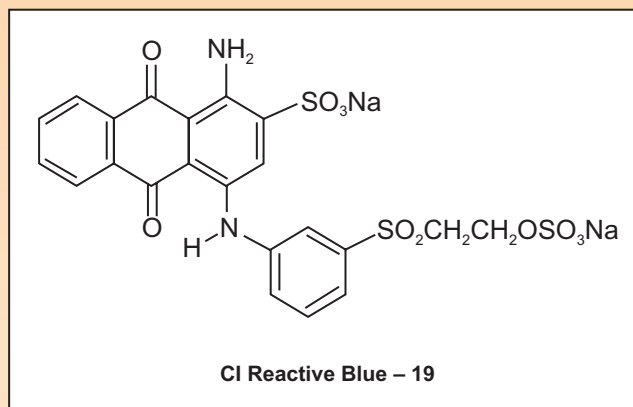

*Pic.2.8 Structure Of Reactive Dye*



### 2.2.6 Disperse Dyes

These dyes were originally developed for the dyeing of cellulose acetate but now a days, they are used to dye nylon, cellulose triacetate and acrylic fibres too.

These dyes were largely used for dyeing of polyester material. Disperse dyes are Non-ionic aromatic compounds with relatively low molecular weight and has an extremely low solubility in water. These dyes are available in the form of powders, granular, liquid or paste form. These dyes can be sublimize at higher temperature and this sublimation properties of Disperse dyes at high temperature is used in the transfer printing and rapid dyeing process.

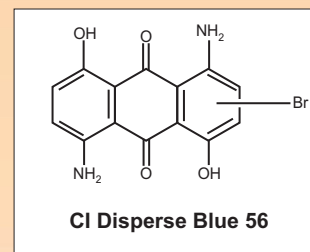

Dyeing of polyester is generally carried out at high temperature and high pressure. These dyes are also used for heat transfer printing. Disperse dyes produces very good range of shades except dark blue and black. These dyes are having good -excellent fastness to perspiration, crocking and dry cleaning and Fair-Good fastness to light and washing. When these dyes are used on acetate, it exhibit poor fastness to light and subject to gas fading.

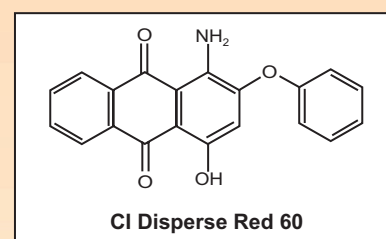

*Pic.2.9 Structure of Disperse Dye*

### 2.2.7 Basic Dyes

Basic dyes are derived from salts of tri phenyl methane derivatives. These are water-soluble dyes and contains cationic group. These dyes are mainly used for dyeing of acrylic and mod acrylics materials. Apart from these, basic dyes can also be used for effectively dyeing of wool and silk but with poor fastness properties. It can also be used for dyeing of nylon.

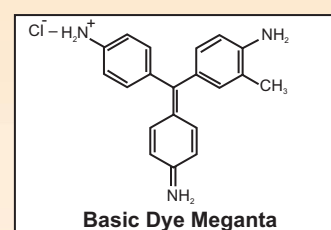

Some variety of polyester can also be dyed with Basic class of dyes. A basic dye produces complete range of bright color with Good color fastness to light, washing, perspiration and crocking for acrylic and mod acrylic. However, it exhibit very poor fastness to washing and light on wool and silk.

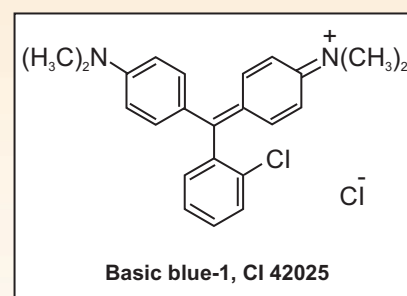

*Pic.2.10 Structure of Basic Dye*



### 2.2.8 Acid Dyes

These dyes are sodium salt of sulphonic acid that are having very good affinity to wool and silk fibre under acidic medium. These dyes are available in a form of salts and are water-soluble. These dyes are applied in acid medium by exhaust method. Acid dyes are mainly used for dyeing of wool and silk. However, Acrylic, nylon and spandex can also be dyed with acid dyes with excellent fastness properties.

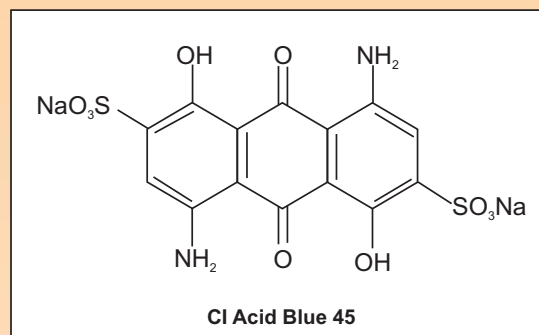

*Pic.2.11 Structure of Acid Dye*

An acid dye produces complete range of color except bright red and greenish blue. However, some of the bright colors tend to bleed while some colors have good colorfastness to light, dry cleaning and crocking. Few of the Acid dye have poor fastness to washing.

### 2.2.9 Chrome / Mordant / Metallic Dyes

In this class of dyes, Metallic salt of cobalt's, aluminum or copper are added to dye molecules for improving fastness properties of the dyes. These dyes are generally water soluble in nature and are applied in acidic medium. Mordent dyes takes more time compare to other class of dyeing. These dyes can be applied in fiber, yarn or fabric form.

Metallic dyes are effectively used for dyeing of wool & silk, where maximum wet fastness is required.

However, Acrylic, nylon, and spandex can also be dyed with mordent dyes. Mordent dyes have excellent fastness to perspiration and washing. Good fastness to light and dry cleaning and very good fastness to crocking.

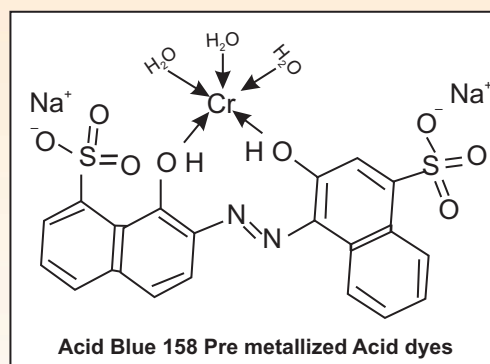

*Pic.2.12 Structure of Metal Complex Dye*



### 2.3 The Selection of Dyes

There are various choices available to dye given fabric. The main criteria for selection of dyes depend upon the following factor.

- End uses of fabric.
- Fiber content.
- Fabric structure.
- Requirement of color fastness.
- Penetration and absorption of dyes.
- Cost of dye stuff.
- Methods of application etc.

### 2.4 Dyeing Objectives

The main objectives of dyeing are.

- To impart color to the Textile substrates [fibers, yarns, fabrics & garments] uniformly and producing uniform leveling.
- To achieve acceptable durability of color to further treatments in production and normal end use.
- To reproduce the required shade from batch to batch.
- To use reasonably priced dyes and dyeing procedure.
- To provide and use eco friendly process.
- Fixing the color in the shortest possible time.

### 2.5 Dyeing Methods

Textile materials can be dyed using following methods –

1. Batch Dyeing.
2. Continuous Dyeing.
3. Semi-continuous Dyeing Processes.

Various type of dyeing methods are used in the industry to dye the textile materials such as fibre dyeing, yarn dyeing, fabric dyeing, and garment dyeing. Apart from these some of the fibre, which are difficult to dye in a conventional dyeing process can be dyed as Dope Dyeing Process.



The type of dyeing process used depends on several things including type of material (fiber, yarn, fabric, fabric construction and garment), type of fiber, size of fabric lots and quality requirements in the dyed fabric.

Machinery used for dyeing must be resistant to attack by acids, bases, and other auxiliary chemicals and dyes. Stainless steel is normally used as the construction material for all parts of dyeing machines that will come in contact with dye formulations.

### 2.6 Batch Dyeing Processes

Batch processes are the most commonly used to dye textile materials. Batch dyeing is also called exhaust dyeing method, because the dye slowly migrating from a dye bath to the material being dyed over a relatively longer period of time. The dye is said to be exhaust -from the dye bath to the substrate. Textile substrates can be dyed in batch processes in almost any stage of their assembly into a textile product including fiber, yarn, fabric or garment. The main advantage of the batch dyeing process is , flexibility in color selection and cost of dyeing is lower.

Some batch dyeing machines operate at below 100°C temperatures only. Closed type of dyeing machine are manufactured in such a ways so that it can be pressurized and provides the capability to dye more than 100°C temperatures. cotton, rayon, nylon, wool and some other fibers dye well at temperatures below 100°C. Polyester and some other synthetic fibers dye more easily at temperatures higher than 130°C.

There are three general types of batch dyeing machines:

- Machines in which the fabric is circulated
- Machines in which the dye liquor is circulated while the material being dyed is stationary and
- Machines in which both dye liquor and material are circulated.

Fabrics and garments are commonly dyed in machines in which the fabric is circulated. The formulation is in turn agitated by movement of the material being dyed. Fiber, yarn and fabric can all be dyed in machines which hold the material stationary and circulate the dye liquor. Jet dyeing is the best example of a machine that circulates both the fabric and the dye bath. Jet dye machines are excellent for knit fabrics, but woven fabrics can also be dyed using jet machines. The some of the examples of batch dyeing machines are Jigger dyeing machine, Winch dyeing machine, soft flow dyeing machine and others.







### Optimizing the Batch Dyeing Process

For any dyers, the ultimate dream is to get the maximum out of the process of dyeing at minimal cost. For a batch dyeing process, the following techniques can prove to be effective for optimum utilization of the machine and cost of dyeing.

- Use machinery that are fitted with latest state-of-the-art automatic controllers.
- Control of temperature and other dyeing cycle parameters.
- Indirect system of cooling and heating.
- Innovative hoods and doors that reduces losses of steam and temperature.
- Choosing the machinery that is exactly sized for the batch that needs to be processed.
- Also confirmation that it is operated exactly within the specified range of nominal material to liquor ratios for which it is designed.

It has been observed that machines that are operated with a consistent material to liquor ratio while being loaded at 60 percent level of their nominal capacity gives optimum results.

With yarn dyeing machines this level can stretch to even 30% of the nominal capacity. Opting new machineries which adheres to the following requirements:

- Liquor ratio that is low-or-ultra-low.
- Complete in process separation of bath from substrate.
- Mechanism that involves smooth internal separation of process liquor.
- Mechanical liquor extraction that brings the carry-over to minimum.
- Reduced cycle duration.
- Replacement of conventional overflow-flood rinsing method with methods like drain and fill or other methods (for example smart rinsing for fabric).
- Proper re-use of rinsed water for the next dyeing session.
- Re-use of the dye bath if technical considerations allows.

### 2.7 Continuous Dyeing Processes

In the continuous dyeing process, textile substrates are continuously fed into a dyeing range. The speeds of dyeing range can vary between 50 to 250 meters per minute depending on the type of the machine and type of fabric used.



A continuous dyeing process typically consists of the following:

- Dye application.
- Dye fixation with heat or chemicals and
- Rinsing or Washing.

Continuous dyeing has been found to be most suitable for woven fabrics. Mostly continuous dye ranges are designed for dyeing blends of polyester and cotton. The step of padding plays a key role in the operation of continuous dyeing. Sometimes Nylon carpets are also dyed in continuous processes, but the design ranges for them is flat fabrics. Warps yarns are also dyed in continuous process in denim industry.

Very good examples of such warp dyeing are long chain warp dyeing and slasher dyeing using indigo. A continuous dye range has been found useful and economically sustainable for dyeing long runs of a given shade. One important factor that separates continuous dyeing from batch dyeing is the tolerance factor for color variation. That is more for continuous dyeing as compared to batch dyeing.

This is because of two reasons:

- a) The speed of the process.
- b) Presence of a large number of process variables which affects dye application.

Some of the popular methods in continuous dyeing process are Pad-steam, Wet-steam, thermosol dyeing, space dyeing, pad-steam dyeing and long chain warp dyeing.

### Optimizing of Continuous Dyeing Process

Continuous and to some extent semi-continuous dyeing processes both are less prone to water consumption than batch dyeing, but results in high concentration of residues. If some strict control measures are taken up then it is possible to reduce these losses of concentrated liquor. The following steps may prove useful.

- Applying low add-on liquor application systems along with minimizing of volume capacity of the dip through when pad dyeing techniques are in operation.
- Adoption of latest dispensing systems, where the chemicals get dispensed on-line as separate streams. They get mixed only at the moment just before the delivery to the applicator.
- Using any of the following systems for dosing of the padding liquor. Important to





know that it should be strictly according to the measurement of the pick up.

- A proper measurement of the dyeing liquor quantity consumption in comparison to the processed fabric.
- The resulting values thus obtained are processed automatically and applied in preparing the next comparable batch.

### Application Technique of Rapid Batch Dyeing

Here the dyestuff solution is prepared just in time, with steps that are based on on-line measurement of the pick-up. This proves better than those dyestuffs that are kept prepared already for the whole batch before the commencement of the dyeing batch. To increase washing efficiency based on the proven principles like reduction of carry-over and counter-current washing.

### 2.8 Semi Continuous Dyeing Process

The process of semi-continuous dyeing consists of pad-batch, pad-jig, pad-roll. In this process, the fabric is first passed through with the dye-liquor, that is called a padding machine or padding mangle. Then it is subjected to batch wise treatment in a jigger. It could also be stored with a slow rotation for many hours. In the pad-batch this treatment is done at room temperature while in pad-roll it is done at increased temperature by employing a heating chamber. This helps in fixation of the dyes on to the fiber. After this fixation process, the material in full width is thoroughly cleansed and rinsed in continuous washing machines.

There is only one point of difference between Continuous and semi-continuous dyeing process, that in semi-continuous dyeing, the dye is applied continuously by a padding. The fixation and washing remains discontinuous. Material to Liquor Ratio in semi-continuous dyeing is not of much importance and is not taken as a parameter.

One of the widely used techniques for semi-continuous dyeing process is the Pad Batch Dyeing.

#### 2.8.1 Solution Dyeing or “Dope Dyeing” or “Mass Coloration”

This type of dyeing process is generally used to dye polyethylene, polypropylene, polyester and viscose rayon. Dope dyeing process is generally used for dyeing of synthetic or semi-synthetic polymers. This method of coloring is actually a part of the manufacturing process of Man made fibers in which the coloring agents are mixed to polymer solution of man made fiber before it is extruded through a spinneret.



Some of the important feature of dope dyeing is as follows:

- Dyed colors solution are fade proof under all conditions.
- Color fastness to light is out standing and is mainly used for Draperies, out door carpets, Automotive fabrics and other applications where long sun light exposure is required.
- To produce darker shades in blue, black, brown and green widely used in fashion apparel fabrics because, range of colors is very limited.
- Very expensive.
- Perfect color and re-production consistency from dye lot to lot can be achieved.
- Solution-dyed fabrics of acetate do not gas fade.

### 2.8.2 Dyeing Machines / Equipment

#### Objectives of Dyeing Machines

To provide maximum contact between the dye liquor and the fibers within reasonable amount of time, without causing damage to the substrates.

#### Classification of Textile Dyeing Machines

For a broader understanding, of the dyeing machines, the Dyeing machines are classified into two types:

1. Rope Dyeing Machine
2. Open Width Dyeing Machine

The selection process of the dyeing machines i.e. whether to opt for rope or open-width is totally dependent on the ability of the fabric to withstand the mechanical demands that is involved in the two processes. Both the type of machine is equally popular. Popular varieties of rope dyeing machines are jets and becks, while the popular varieties of open-width dyeing machines are beams, followed by jigs and pad-batch.

#### Rope Dyeing & Rope Dyeing Machine

In the case of rope dyeing machines, the fabric gets transported via the machine in a





loosely collapsed form that looks like a rope. Rope dyeing has the tendency for abrasion of fabrics and result in permanent, cracks, creases and streaks.

### Open Width Dyeing Machines

In the case of open width dyeing machine, the fabric gets maintained at all times in a flat and open condition. As Open-width dyeing works by applying tension to fabrics and this has the potential to form edge marks along with creases in tubular knit goods.

### Types of Textile Dyeing Machines

Most of the Textile Dyeing Machines utilize latest advancement in the dyeing technology to give high capacity dyeing along with uniformity and smooth finishes.

1. Beam Dyeing Machine
2. Hank Dyeing Machine
3. Jet Dyeing Machine
4. Jig Dyeing Machine
5. Paddle Dyeing Machine
6. Package Dyeing Machine
7. Winch Dyeing Machine
8. Sample Dyeing Machine

### 2.8.3 Stock Dyeing

In this process of dyeing, loose fibers are dyed by circulating the dye liquor continuously through fibers.

#### Important Features of Stock Dyeing:

- Expensive method of dyeing
- Production is less
- 10-15% waste of dyed fibers during dyeing
- Excellent penetration of dye in to fiber



- Fashion risk - It means that final color of the fabric has to be decided in earliest stage in its manufacture

**Reason for use:**

- Heather-like effect for woolen yarns or to produce “Melange yarns”



*Pic.2.13 Stock Dyeing Machine*

**2.8.4 Yarn Dyeing**

In this type of Dyeing machines, dyeing is carried out in yarn stage. There are various types of yarn dyeing machines; such as Slacer Dyeing Machine, Rope Dyeing Machine, Hank dyeing Machine ,Package Dyeing and Space dyeing.

**Important Features of Yarn Dyeing**

Some of these dyeing machines are cheaper than Stock Dyeing Machine:

- Excellent color penetrations of dye into fiber than piece dyeing





**Reason for Use,**

- To produce stripes, plaids and checks and other multi colored designs.



*Pic.2.14: Yarn Dyeing Machine*

**2.8.5 Skein Dyeing**

In this type of dyeing loosely wound hanks (skeins) of yarn are immersed into dye containers.

**Important features of Skein Dyeing:**

- It is Suitable for knits and carpets where a fuller bulk is more desirable
- Cotton, woolen, silk and bulk acrylic yarns are generally dyed by this method.



*Pic.2.15 Skein Dyeing Machine*

### 2.8.6 Package Dyeing

In this type of dyeing, yarns are wound on packages in the form of spools, cones or similar units and these packages of yarn are stacked on perforated rods in a rack and then immersed in a tank. In that tank, the dye is forced outward from the rods under pressure through the spools and then back to the packages towards the center to penetrate the entire yarn as thoroughly as possible.

Important Features of Package Dyeing

- More suitable for woven and knitted fabrics.
- Can be performed larger scale.
- Gives uniform results.
- Yarn package is stationary and dye liquor is circulated from inside to outside of the package.
- Package tension is critical factor to get uniform dyeing; Can be used for to dye loose fibers, slivers, warp yarns and fabric with proper modification.



*Pic.2.16 Package Dyeing Machine*

### 2.8.7 Beam Dyeing

It is a larger version of package dyeing, in which, Yarns or full width of woven or knitted fabric is wound on a perforated cylindrical beams and enclosed in to a container. Dyestuff





is circulated under pressure through perforation, same as package dyeing machines. In this type of dyeing Warp yarns are dyed in the solid colour, prior to weaving or warp knitting

### Important Features Beam Dyeing

- Provides for good color absorption.
- Better color fastness than piece dyed methods.

### Advantages of a Beam Dyeing Machine

The fabric is put under controlled tension, and is wound on to a perforated beam. This results in elimination of creases from the fabric. It also ensures total control of dimensions of the roll of fabric. The fabric is not allowed to do any movement during the process of dyeing. This actually means that there is no application of mechanical action on to the fabric. As shown in the Pic.2.17, there is no movement of the fabric as the hydrostatic pressure of the pump forces the dye liquor through the fabric roll.

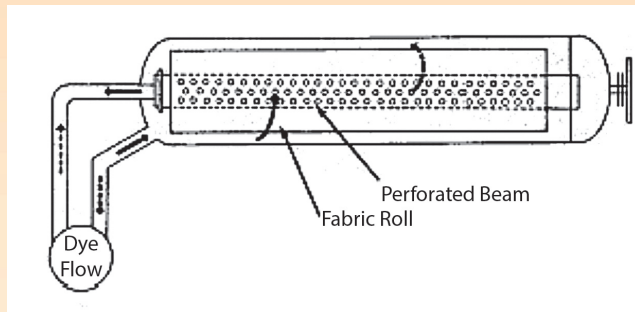

*Pic.2.17 Beam Dyeing Machine*

### 2.8.8 Piece Dyeing

In this method, dyeing of cloth is carried out, after it is being woven or knitted is known as piece dyeing. It is the most common method of dyeing. The various methods used for this type of dyeing include jet dyeing, jig dyeing, pad dyeing and beam dyeing. Dyeing is carried out in fabric stage, generally to produce single solid color in the substrate.

### 2.8.9 Winch Dyeing/Beck Dyeing

It is a conventional type of dyeing machine consisting of a tub containing the dye liquor and an elliptical winch or reel which is located horizontally above the dye bath. In this machine both the ends of fabric are stitched together to make continuous rope form and is passed through the dye bath. The fabric is submerged in the dye bath and circulated repeatedly. Fabric is held in a slack or loose condition during dyeing.



### Important Features of Winch Dyeing

- Mainly used for knits and lightweight fabrics.
- Filament yarn fabrics should not be dyed.
- Very light weight fabrics should also be avoided.
- Dyeing is carried out at high liquor ratios. (1:20 to 1:50).

### Disadvantages of Winch Dyeing

- Low substantivity dyes (Reactive dyes) are not advisable.
- Difficult to maintain uniform temp throughout the dye bath.



*Pic.2.17 Winch Dyeing Machine*

### 2.8.10 Space Dyeing

In this method, the yarn is dyed at intervals along its length. For these two procedures-knit- de-knit method and OPI Space-Dye Applicator- are adopted. In the first method, the yarn is knitted on either a circular or flat-bed knitting machine and the knitted cloth is then dyed and subsequently it is de-knitted. Since the dye does not readily penetrate the areas of the yarn where it crosses itself, alternated dyed and undyed spaces appear.

The OPI Space-Dye Applicator technique produces multi coloured space dyed yarns. The yarns are dyed intermittently as they run at high speeds of upto 1000 yards (900 m) per minute through spaced dye baths with continuous subjection to shock waves produced by compressed air assuming supersonic velocities.

### 2.8.11 Jig Dyeing Machine

In this machine, Fabric is dyed in its open or full width. The machine consists of a small tub and two drawing rollers located above the dye bath. First the fabric is wound around one of the rollers; during dyeing the fabric is passed through the dye bath and rewind on to the second roller. When all the fabric is passed through the dye bath the direction of movement is reversed, this would be repeated until the dyeing is completed. During dyeing tension is imparted in length of the fabric:



### Important Features of Jig Dyeing Machine

- Suitable for Medium Weight fabrics & Heavy Weight Fabric.
- Low liquors ratios (1:2 to 1:6).
- The consumption of chemicals and energy is low.
- In new jigs are equipped with devices that allow a reduction in tension applied in lengthwise.



*Pic.2.18 Jig Dyeing Machine*

### Limitation of Jig Dyeing Machine

- Knitted and stretch woven fabrics can not be used.
- Possibility of shade variation center to selvedge.

### 2.8.12 Jet Dyeing Machine:

Jet dyeing machines are a very efficient in term of contact between the dye liquor and fabric . In this machine both fabric and dye liquor are in continuous movement. This improves level of dyeing in shorter dyeing time. Fabric is circulated through the dye bath in rope form. The movement of the fabric occurs by circulating the dye-liquor through a venturi jet. Jet dyeing machine's are pressurized and dyeing can takes place at high temperature 135-150°C. Jets are builds to be used at low liquor ratios between 10:1 and 5:1 and lower.

### Advantages of Jet Dyeing Machines:

- Less consumption of water, energy and chemicals
- Shorter dyeing cycle time
- Efficient and high production rate
- Delicate woven / Knits, textured and lightweight fabrics can be dyed.



### There are three types of Jet Dyeing Machines

- (i) Jet Dyeing - Overflow Dyeing Machine
- (ii) Soft Flow Dyeing Machine
- (iii) Airflow Dyeing Machine

Overflow Dyeing Machines are designed for use in delicate knitted and woven fabrics that are made up of natural as well as synthetic fibres. They are also extensively used in the production of carpets. The main difference between jet and overflows machines is that in jet machines the fabric gets transported by a bath that flows at high speed through the nozzle, while in Overflow Dyeing Machine it is the gravitational force of the liquor overflow that is responsible for fabric transportation.

### Functioning of a Overflow Dyeing Machine

In a typical Overflow Dyeing Machine a winch that is not motor driven usually is located in the top side of the machine where the fabric is hanged. A longer length of textile is made to hang from the exit side of the winch as compared to the inlet side. By applying the force of gravitation the longer length of textile is pulled downward more strongly than the shorter one. Consequently the fabric is soaked in the bath without any sort of tension.



*Pic.2.19: Overflow Dyeing Machine*

### Advantages of Overflow Dyeing Machine

**No Evaporative Losses-** As the dyeing vessel is closed, there is no evaporative losses of steam from the dye bath. Further, depending on the situation the temperature may be





raised to more than 100°C.

**No Build Up Of Steam Condensate In The Dye Bath-** The latest technology implies that the Dye bath gets heated by a heat transducer which is steam driven. This technology apart from being very efficient ensures that there is no build up of steam condensate in the dye bath.

**Low Liquor Ratios-** Dyeing is conducted at relatively low liquor ratios, e.g. 10:1 and may be lesser resulting in substantial savings in water and energy.

**Excellent Dye Liquor Contact-** Excellent dye liquor contact with the fabric rope results in better and more improved level dyeing.

**Computer Control-** The machines are operated by computer and hence, operator error is eliminated.

### (ii) Soft Flow Dyeing Machine

- In the soft flow dyeing machine water is used for keeping the fabric in circulation. The Connectional difference of this equipment from a conventional jets that operates with a hydraulic system is that the fabric rope is kept circulating during the whole processing cycle (right from loading to unloading). There is no stopping of liquor or fabric circulation for usual drain and fill steps.
- The principle working behind the technique is very unique. There is a system for fresh water to enter the vessel via a heat exchanger to a special interchange zone. At the same time the contaminated liquor is allowed channel out through a drain without any sort of contact with the fabric or for that matter the new bath in the machine.

### Key Features of Soft Flow Dyeing Machine

- Significant savings in processing time.
- Savings in water that is around 50%.
- Excellent separation of different streams results in optimum heat recovery and a distinct possibility of further use or a dedicated treatment.

### Types of Soft Flow Dyeing Machine

A few of the commercially popular brands along with their particular technical specifications are listed below.



### (A) Multi Nozzle Soft Flow Dyeing Machine

Technical Features:

- Very Low Liquor ratio - around 1:1 (Wet Fabric) Can Reach High Temp. up to 140°C
- Easy to Dye 30 to 450 g/mt.sq. of Fabrics (Woven & Knitted Fabrics)
- Number of Very Soft-flow Nozzles
- No Pilling Effect
- Wide Capacity

### (B) High Temperature High Pressure Soft Flow Dyeing Machine

Technical Features:

- Compact Body made of Stainless Steel.
- High Efficiency Heat Exchanger for Quick Heating / Cooling.
- Heating Rate - Around 4°C/Min upto 90°C - Around 3°C/Min up to 135°C At steam pressure of 6 Bar.
- Cooling Rate- Around 4°C/ Min At Water Pressure of 4 Bar and 15°C.
- Maximum Working Temp is 135°C.
- Maximum Working Pressure of 3.2 Bar.
- Control Manual as well as Automatic.
- Heavy Duty Stainless Steel Pump.

### (iii) Jet Dyeing Machine-Airflow Dyeing Machine

This is another development of the very popular jet dyeing machines. The main difference between the Air Flow Machine and Jet Dyeing machine is that the airflow machine utilizes an air jet instead of the water jet for keeping the fabric in circulation. Typically the fabric is allowed to pass into the storage area that has a very small amount of free liquor. This results in a reduction in consumption of water, energy and chemicals. Here the fabric does not remain in touch with the liquor (the bath used is below the basket that holds the fabric in circulation). This invariably means that the bath conditions can be altered without having any impact on the process phase of the substrate.





### Advantages of Airflow Machine

- Completely Separated circuit for liquor circulation without getting in touch with the textile
- Bath less Dyeing Operation
- Rinsing Process offers all the added benefits of continuous processing as it is no longer a batch operation
- Extremely Low Liquor Ratio
- Virtually Non Stop Process
- Comparatively lesser energy requirement due to faster heating/cooling and optimum heat recovery from the hot exhausted dye liquors
- Reduction in consumption of the chemicals (e.g. salt) dosage of which is based on the amount of dye bath
- Lesser Water Consumption savings up to 50% from the Conventional Jet Dyeing Machines
- Sensitivity towards Ecology
- Economical Operation
- More Safety while Dyeing
- Unique Water Saving Capacity Of Air Flow Machine
- Water remains a perpetual challenge for the world as the most precious resource and textile dyeing processes are notorious for consuming gallons of water. The latest technology of Airflow Machine surely takes care of such problem.
- Airflow dyeing machine can operate at a liquor ratio that is even below 1:5 while a conventional hydraulic dyeing system generally operates with a liquor ratio of about 1:10. It is worthwhile to know that exchanging the liquor ratio of 1:10 from a single 300 kg dye lot to ratio of 1:5, can result in water savings corresponding to an average monthly water consumption of one person in a big country like Germany.

### 2.8.13 Garment Dyeing

This type of dyeing is generally carried out for the garments of non-tailored categories, such as sweaters, sweat shirts, hosiery and panty hoses etc. Tailored items like suits or dresses cannot be dyed as garments because the difference in shrinkage of the various components of the garments will provide the distortion and misshape the article.



Garment dyeing is done by, placing suitable number of garments depending on the capacity of the machine into large nylon net bag. Loosely packed 10-50 bags are then placed in dye bath and kept agitated by a motor driven paddle. This type of machine is also called as “Paddle dyer”.

#### Important Features of Garment Dyeing:

- Less fashion risk
- Material need not be dyed until shortly before the actual sale of the merchandise



*Pic.2.20: Garment Dyeing Machine*

#### Limitations

- All fabric used in one garment must come from the same lot of fabric.
- Fabric must be tested for shrinkage before cutting of garments, and must be given required tolerance to allow for shrinkage so that size will be accurate.
- Thread must be selected carefully and tested to be sure it will accept the dye in the same way as the fabric.
- Labels, buttons and zippers must be compatible with the garment fabric in terms of reaction to the dye and shrinkage.

#### 2.8.14 Special Dyeing Effects

##### Cross Dyeing

Yarn, fabric or even garment made with two or more generic fiber types “Blends” having different dyeing qualities is dyed a single dye bath containing different classes of dyes.

E.g. If a fabric is made of 67% Polyester and 33 % cotton fibres. In such case both the fibre requires two different classes of dyes. And if we choose one colour to dye the polyester fibre (say Yellow) than any colour other than yellow can be used in the to dye the cotton, then such type of dyeing is called Cross dyeing.

If different fibers are blended in the same yarn a Heather-like effect is obtained. Different fiber content yarns used in fabric construction can obtain plaids, stripes and checks.





*Pic.2.21 Cross Dyeing Fabric*

### **Union Dyeing**

Union dyeing can be defined in the blended fabrics. If a fabric is made of 67% Polyester and 33 % cotton fibres. In such case both the fibre requires two different class of dyes. And if we choose one colour to dye the polyester fibre than similar colour must be used in the same intensity to dye the cotton, then such type of dyeing is called Union dyeing.

It means that Union dyeing is achieving single solid color on blended fabrics.

### **Warp-Beam Dyeing**

It is similar to package dyeing but more economical. Here, yarn is wound on to a perforated warp beam, immersed in a tank and dyed under pressure.

### **Batchwise or Exhaust Dyeing**

This method is uses lot of water, because such type of machines are designed with high material to “Liquor Ratio (ratio between water and goods)” This should immerge the goods into dye solution for a long time in order to let the dye penetrate into the goods. This will lead to produce more waste water than the continuous process.

### **Terminology Used in Dyeing Process**

#### **Material to Liquor Ratio (M:L Ratio)**

Volume of water taken in relation to weight of material (fibre, yarn or fabric)



E.g. M:L :: 1:10 means, for 1 kg of textile material, 10 litres of water taken for dyeing

**% Dyebath Exhaustion:** Amount of dye gone from solution phase to fibre phase at the end of dyeing period expressed in terms of %. It is a measure of dye substantivity. The term is mainly applicable to batchwise dyeing.

**% Fixation:** Amount of dye fixed (interacted) with fibre after washing/soaping.

### 2.9 Styles of Dyeing

#### Resist Dyeing

Resist-dyeing is a term for a number of traditional methods of dyeing textiles with patterns. Methods are used to “resist” or prevent the dye from reaching all the cloth, thereby creating a pattern and ground. The most common forms use wax, some type of paste, or a mechanical resist that manipulates the cloth such as tying or stitching. Another form of resist involves using a chemical agent in a specific type of dye that will repel another type of dye printed over the top. The most well-known varieties today include tie-dye and batik.

#### Basic Methods

**Wax or Resist:** Melted wax or some form of paste is applied to cloth before being dipped in dye. Wherever the wax has seeped through the fabric, the dye will not penetrate. Sometimes several colors are used, with a series of dyeing, drying and waxing steps. The wax may also be applied to another piece of cloth to make a stencil, which is then placed over the cloth, and dye applied to the assembly. This is known as resist printing. Paper stencils may also be used as another type of resist printing. The same method is used in art in printmaking or in one form of screen printing.

**Mechanical Resist:** The cloth is tied, stitched, or clamped using clothes pegs or wooden blocks to shield areas of the fabric.

**Chemical Resist:** a modern textile printing method, commonly achieved using two different classes of fiber reactive dyes, one of which must be of the vinyl sulfone type. A chemical-resisting agent is combined with dye Type A, and printed using the screen print method and allowed to dry. A second dye, Type B, is then printed overtop. The resist agent in Type A chemically prevents Type B from reacting with the fabric, resulting in a crisp pattern/ground relationship.

#### Tie-Dye

Tie-dye is a process of resist dyeing textiles or clothing which is made from knit or woven





fabric, usually cotton; typically using bright colors. It is a modern version of traditional dyeing methods used in many cultures throughout the world. “Tie-dye” can also describe the resulting pattern or an item which features this pattern. Tie-dyeing became fashionable in the West in the late 1960s and early 1970s as part of hippie style.

Tie-dyeing is accomplished by folding the material into a pattern, and binding it with string or rubber bands. Dye is then applied to only parts of the material. The ties prevent the entire material from being dyed. Designs are formed by applying different colors of dyes to different sections of the wet fabric. A wet t-shirt is much easier to use rather than just dyeing on a dry t-shirt. Once complete, the material is rinsed, and the dye is set.

### **Mudmee Tie-Dye**

Mudmee tie-dye is mainly created in Thailand and neighboring part of Laos. It uses different shapes and colors than other types of tie-dye, and the colors are, in general, more subdued. Another difference is that the base color is black.

### **Fold And Patterns**

Below is a list of common modern tie-dyeing folds and patterns.

#### **Spiral**

Spiral patterns are created by gathering a small section, usually with a clothes pin or a kitchen fork, in the middle of the fabric and slowly rotating the piece creating pleats of fabric arranged in swirls around a central point. It is then gathered into a flat round bundle and the different wedges of the circular bundle are usually dyed different colors to create a greater spiral effect.

#### **V**

The ‘V’ shape is achieved by folding a shirt in half vertically, then a line is drawn diagonally from the shoulder area down to the center fold of the shirt. The fabric is then accordingly folded along the line and bound into one or more areas to which the dye is applied. This will show in the shape of a ‘V’.

#### **Random**

This category can hold several different patterns, the majority of which have nothing to do with each other; they can be combinations or they can be as chaotic as bundling the item to be dyed.



### Random Circles

This effect is made by tying knots with string or elastic bands in different places. More the distance from the centre of the fabric that is tied, the larger the circles.

### Batik

Batik is a cloth that traditionally uses a manual wax-resist dyeing technique. Batik or fabrics with the traditional batik patterns are found in Indonesia, Japan, China, Azerbaijan, India, Sri Lanka, Egypt, Nigeria, Senegal, Malaysia and Singapore. Javanese traditional batik, especially from Yogyakarta and Surakarta, has notable meanings rooted to the Javanese conceptualization of the universe. Traditional colors include indigo, dark brown, and white, which represent the three major Hindu Gods (Brahmā, Visnu and Śiva). This is related to the fact that natural dyes are most commonly available in indigo and brown. Certain patterns can only be worn by noble people; traditionally, wider stripes or wavy lines of greater width indicated higher rank. Consequently, during Javanese ceremonies, one could determine the royal lineage of a person by the cloth he or she was wearing.

### Types and Variations of Batik

**Javanese Kraton Batik** (Javanese court Batik) Javanese kraton (court) Batik is the oldest batik tradition known in Java. This type of batik has earthy color tones such as black, brown, and dark yellow (sogan), sometimes against a white background. The motifs of traditional court batik have symbolic meanings. Some designs are restricted: larger motifs can only be worn by royalty; and certain motifs are not suitable for women, or for specific occasions (e.g., weddings). The palace courts (keratonan) in two cities in central Java are known for preserving and fostering batik traditions.

**Surakarta (Solo City) Batik** Traditional Surakarta court batik is preserved and fostered by the Susuhunan and Mangkunegaran courts. The main areas that produce Solo batik are the Laweyan and Kauman districts of the city. Solo batik typically has sogan as the background color. Pasar Klewer near the Susuhunan palace is a retail trade center.

**Yogyakarta Batik** Traditional Yogya batik is preserved and fostered by the Yogyakarta Sultanate and the Pakualaman court. Usually Yogya Batik has white as the background color. Fine batik is produced at Kampung Taman district. Beringharjo market near Malioboro street is well known as a retail batik trade center in Yogyakarta

### Pesisir Batik (Coastal Batik)

Pesisir batik is created and produced by several areas on the northern coast of Java and on Madura. As a consequence of maritime trading, the Pesisir batik tradition was more





open to foreign influences in textile design, coloring, and motifs, in contrast to inland batik, which was relatively independent of outside influences. For example, Pesisir batik utilizes vivid colors and Chinese motifs such as clouds, phoenix, dragon, qilin, lotus, peony, and floral patterns.

**Pekalongan Batik** The most famous Pesisir Batik production area is the town of Pekalongan in Central Java province. Batik Pekalongan was influenced by both DutchEuropean and Chinese motifs, for example the buketan motifs was influenced by European flower bouquet.

### Exercise

#### Fill in the blanks

1. ....are used to impart color to the textile materials.
2. ....must have substantively to the fiber during dyeing stage.
3. .... must have solubility in water during dyeing stage.
4. Durability of the ....depends upon binders used.
5. Vat dyes are .....organic compounds and not substantive to cellulose.
6. ....are derived from aryl amides organic compounds.
7. .... derived from formulation of Benzedrine salts.
8. .... derived from the formulation of compounds containing sulfur.
9. Ramazol is ..... type of reactive dye.
10. .... can be used for heat transfer printing.
11. .... dyeing is generally carried out high temperature/pressure
12. .... dyes are derived from salts of tri phenyl methane derivatives.
13. ....are water-soluble and contains cationic group.
14. .... are water-soluble and are applied in acid medium; Mainly used for wool and silk; acrylic, nylon and spandex.
15. Metallic salt of cobalt's, aluminum or copper are added in ..... dye molecules for fixing dyes.



16. In ..... the coloring agents are mixed to polymer solution of man made fiber before it is extruded through a spinneret.
17. Yarn, fabric or even garment made with two or more generic fiber types “Blends” having different dyeing qualities is dyed a single dye bath containing different classes of dyes is called as .....
18. ....is achieving single solid color on blended fabrics.

### Write short notes on

1. Stock dyeing machines
2. Yarn dyeing machines
3. Winch dyeing machines
4. Jig dyeing Machine
5. Jet dyeing Machine
6. Garment Dyeing
7. Cross dyeing
8. Union dyeing
9. Solution dyeing “Dope Dyeing” “Mass Coloration”
10. Write important feature of the following dyes
  - Vat dyes
  - Azoic/Naphthol dyes
  - Direct dyes
  - Sulfur dyes
  - Reactive dyes
  - Disperse dyes
  - Basic dyes
  - Acid dyes
  - Chrome / mordant / metallic dyes





## UNIT III

### TEXTILE PRINTING

#### Learning Outcome

After finishing the unit, students will be able to understand –

- Various terminology used in textile printing.
- Styles and methods involved in printing.
- Various effects produced by various styles of printing.
- Limitation of the printing methods.

#### Overview

In this unit the students will get to know about the printing, printing methods, techniques and various styles used in the mills. After studying this chapter student will be able to recognize various types of prints available in the markets and how these prints are produced in the industry. They will also be able to understand the limitation and advantages of each types of prints.

#### TEXTILE PRINTING

Printing is a surface ornamentation technique, in which boundary of each colour are fixed by the manufacturer. Or we can say that Color designs are developed on fabrics by printing with dyes and pigments in a paste form with specially designed machines. Printing is used to apply coloring in localized areas only so it is also called localized Dyeing. Printed fabrics usually have clear-cut edges in the printed portions on the face of the fabric. Printing allows for great design flexibility and relatively inexpensive patterned fabric.

To restrict the boundary of the colour printing paste is prepared. Printing paste's main ingredients are colouring matter and thickener, apart from these number of other chemicals are also used in the printing paste which is having specific purpose. The essential ingredient's should be selected from the following.

- I. Dyes/ Pigments
- II. Solvents
- III. Hygroscopic Agents



- IV. Wetting Agents
- V. Thickeners
- VI. Oxidising Agents
- VII. Reducing Agents
- VIII. Catalyst
- IX. Defomer or Defoaming Agents
- X. Mild Oxidising Agents
- XI. Acids or Alkalis
- XII. Carriers
- XIII. Miscellaneous Chemicals

**Dyes or Pigments:-** Dyes or Pigment are selected as per the Fibres and shade percent. Such as Acid dyes should be used for Wool and silk printing, or Disperse dyes should be used for the Polyester printing paste.

**Solvents:-** Solvents are used for to dissolve the dyes and pigments and prevent precipitation. Such as Water, Ethylene glycol, Diethylene glycol, Thiodiethylene glycol.

**Hygroscopic Agents :-** Urea and Glycerine are generally used as hygroscopic agents in the Printing paste. They absorb sufficient amount of water and dissolve the dyes and carries it deeper into the fibres, during the fixing of dyes in the printing .It also helps in the subsequent removal of printing paste in washing operation. Optimum amount of Hygroscopic agents must be used in the printing paste for better results. If too much Hygroscopic agents are used then we will not get sharp printed boundary, and if too less is used then their will be lighter printed surface.

**Wetting Agents :-** Wetting agents are generally used to get the smooth and lump free paste. In case of insoluble dyestuff like Vat, Napthol, and Sulphur dyes the wetting agents are used. Turkey Red Oil is Most commonly used wetting agents.

**Thickeners:-** Thickener are used to provide the body to the printing paste. The main objective of the thickener is to prevent the spreading of dyes beyond the specified boundry. The thickener should be compatible with dyes and should not have affinity or reactivity with dyes and other chemical present in the printing paste.The commonly used thickener are Starches and Gums, Sodium Alginate, Carboxy Methyle cellulose, Methyle Cellulose, ethyle cellulose and emulsion thickener.







**Oxidizing Agents** :- These are used for developing of final colour in case of Solubilised vat dyes, aniline black, etc. Sodium dichromate is used as an oxidizing agent in Discharge printing of Indigo. Some of the examples of Oxidising agents are Sodium bromate, Chlorates, Nitrates, Nitrites, and Potassium Ferrocyanide.

**Reducing Agents** :- These chemicals are used mainly for discharge printing. Some of the common discharging agents are Sodium hydrosulphite, Rangolite C (Sodium Sulphoxylate Formaldehyde) and Sodium bisulphite.

**Catalyst** :- These are used to accelerate the rate of reaction of development of oxidizing agents, reduce the risk of tendering of fibres. Some of the common catalyst are Potassium Ferrocyanide, Copper Sulphide, Ammonium Vanadate.

**Defomer of Defoaming Agents** :- The wetting agents present in the printing paste, during continuous churning and mixing operation generate considerable amount of foams, which produces lighter shades or faulty printing. To avoid this problem, Defoaming agents are used. Emulsion of sulphated sperm oil and pine oil mixture are generally used as Defomer.

**Mild Oxidizing Agents** :- These are used to prevent the reduction of colour during steaming. The commonly used chemical for mild oxidation is Sodium meta nitro benzene sulphonate.

**Acids or Acid liberating agents** :- Weak acids like citric acid, tartaric acid are generally used to adjust the pH of the Printing Paste. Sometimes acid liberating agents are also used to create the acidic conditions at the time of steaming. Some of the examples of these chemicals are Ammonium Chloride, Aluminium Sulphate, Ammonium sulphocyanide etc.

**Carriers** :- They are mainly used for fixing of disperse dyes on polyester or polyester blends at temperature below 100°C.

**Miscellaneous Chemicals** :- Cellulose ethers and esters are used as auxiliaries to thicken the paste and protect the Dyes. These chemicals dissolve in water but coagulate on boiling, they also coagulate under alkaline condition.

### Classification of Printing

Printing can be divided into two categories

1. Methods of Printing
2. Style of Printing



There are various methods of printing

- Stencil Printing
- Hand Block Printing
- Hand Screen Printing
- Flat Bed Screen Printing
- Rotary Printing
- Roller Printing
- Digital or Inkjet Printing

### 3.1 Stencil Printing

This is the oldest method of printing in which design are cut out from flat sheet of metal or waterproof paper or plastic sheet or laminated sheet and colour is applied by brushing or spraying on it.

#### Advantages of Stencil Printing

- This is simplest and cost effective method & does not require expensive equipment.
- Change in design is rapid process and can be used to execute small order.
- Great variety of graded colour effect can be achieved from one stencil by blending different colours on different parts of stencils with one single stroke of brush.

#### Limitations of Stencil Printing

- Complete rings or circles as well as unbroken lines can not be printed by this method.
- The process is manual and laborious.
- This method is not suitable for large scale of production.

### 3.2 Block Printing

This is also very old and simplest method of printing in which the designs are engraved on the seasoned Teak wood. This blocks are then immersed into the oil for several weeks which makes it water and chemical resistant.





To print the correct registration of block on the cloth, “Pitch Pins” are fixed around the side of the block, which print tiny dots on the cloth, These pins are so arranged that they coincide in the pattern and each impression joins up and make perfect print.

### Advantages of Block Printing

- It is simple to operate and does not require expensive equipment.
- There is no limitation of number of colours and reproduction of design is very easy.
- The prints produced by this method are have great decorative value and craftsmanship.

### Limitations of Block Printing

- This is slow process and cost of production is high.
- Making a new blocks are time consuming and difficult.
- It is somewhat difficult to join the each impression of repeat perfectly each time.
- Printing of very long blocks or wide repeat is not possible due to weight and handling issues.
- It is difficult to produce fine lines by this method.

### 3.3 Hand Screen-Printing

This is the best method for printing of low yardage, samples of exclusive limited quality of designs. Screens are generally made of polyester fabric. Sometimes this fabric is also called bolting Cloth, because fabric is tightened on a light weight metal frame. In this type of printing large repeat sizes are possible (up to 120”).

### Advantage of Hand Screen Printing

- Wet-on dry prints effect possible.
- Better penetration of color than roller prints due to heavier lay-on of color.
- Acceptable to all woven & knitted fabrics.
- Rapid preparation of screens and rapid pattern changes over possible.
- Ability to print cut garment parts and small items (towels, scarves etc.)



### Limitations of Hand Screen Printing

- Half tone designs are not possible
- Fine-line paisley prints are not possible
- Lengthwise stripe designs can not be printed
- Slow production
- Uneconomical for large scale production of yardage.

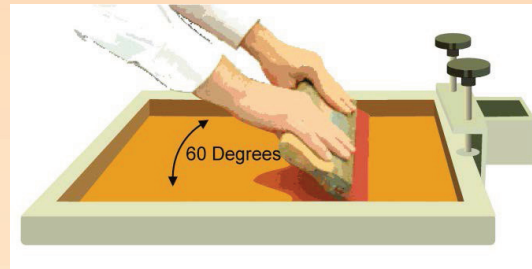

*Pic.3.1 Hand Screen-Printing*

### 3.4 Automatic Flat Bed Screen Printing

This is very similar to hand screen printing, but here the fabric is put on the movable bed. And after each printing application, new surface comes on the bed for next application.

#### Important Features of Automatic Flat Bed Screen Printing

- Large repeat size (up to 60") is possible
- Better color definition than roller prints; and equal to hand screen printing.
- Adaptable to all woven & knits.
- Rapid changeover of designs possible.
- Best machine registration.

#### Limitations of Automatic Flat Bed Screen Printing

- Cost of screen preparation and special mountings are more costly than hand screen printing.
- Not adaptable to low yardage.
- Half-tone designs are not possible.





- Fine-line paisley prints are not possible to print.
- Lengthwise stripes are not possible to print.



*Pic.3.2 Flat Bed Screen Printing Machine*

### 3.5 Rotary Screen Printing

In this type of printing, the screen is circular in shape. And screen are made up of fine gauge of perforated and chemical resistant metal sheets.

#### Important Features of Rotary Screen Printing

- Up to 40-inch repeat size are possible that are larger than roller printing but smaller than flat bed screen.
- Lengthwise stripe effect are possible to print.
- Fall-on designs are possible to print.
- Adaptable to all woven & knitted fabrics.
- Cleaner and brighter colors are possible to compare to roller print.
- Excellent color penetration, but less than flat bed screen prints.
- Rapid change over of designs are possible.
- Efficient for long runs and moderately small (1000 yards) runs.



### Limitations of Rotary Screen Printing

- Fine-line and paisley prints are not possible to print.
- Half tone designs are not as effective as in roller printing.

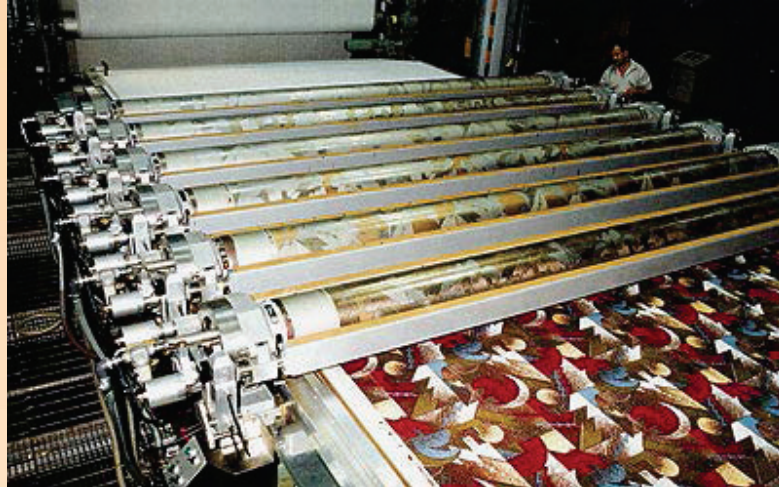

*Pic.3.3 Rotary Screen Printing Machine*

### 3.6 Heat Transfer Printing

In this process of printing, the designs are first printed with special type of disperse dyes on the paper and then this paper is put on the fabrics and High temperature is applied on the fabric for very short duration,

Since the disperse dyes are having properties of sublimation, so colours as per the design will transfer from paper to fabric and redeposit on the fabric surface permanently. This type of printing is also called as Transfer Printing.

#### Important Features of Heat Transfer Printing

- Produces bright, sharp, clear fine-line designs.
- Ability to print cut garment parts and small items.
- Adaptable to long and short yardage runs.
- Rapid pattern changeover are possible.
- Simple, low-investment installation steamers, washers, dryers, etc are not required.
- Fewest seconds are required for all printing processes.
- Heat setting is also accomplished.





### Limitation of Heat Transfer Printing

- Lead-time for paper preparation can cause problems in high fashion markets.
- Fiber content in fabric should be minimum 50% synthetic Fiber.
- Cellulose's & protein fibers cannot be printed.
- Over print only on pastels or else will not completely cover the original color.

### 3.7 Styles of Prints

These are specific features in the prints, which provide the unique identity to the prints. Such types of effects are not possible by any other methods of the prints. Such as the merging effects of two or more colours are only possible in the Tie and Dye styles or the cracking effect within the colour are only possible in the Batik style of printing.

### 3.8 Direct Prints

This print is also called an application print and it is most popular types of print style. In this print design is printed directly onto a white cloth or over a previously dyed pale coloured fabric. In this print, the printed portion is considerably darker than the dyed backgrounds.

#### Identification of Direct Prints

The background is generally white, or has larger portions of white background.

The printed design is lighter in shade on back of the fabric than on the face. This may not be evident on lightweight fabrics because of the strike-through of the print paste.

#### Identifications of Over Print

The background color is the same shade as on the face and the back (piece dyed) and the print design are substantially darker than the background.

### 3.9 Discharge Prints

In this type of prints, Fabrics are generally dyed in a solid color, prior to printing, the design is applied by screen or roller with a chemical (sodium sulfoxylate formaldehyde, a reducing agent). This reducing agent will destroy the colour in the printed portion and white background will appear in the printed area.



For example, “White discharge print” White polka dot on a blue background can be made by first dyeing the fabric blue, then printing appropriate dots with the chemical which removes the blue color.

The colour-destroying chemical does not affect on vat dyes so that “Color discharge Print” can also be produced. For color discharge, these two substances (the color removing chemical and vat dye) may be mixed together in the same print paste and applied in the similar fashion.

When printing with this mixture, the color-removing chemical removes the previously dyed background color while the vat dye color is simultaneously printed on the fabric.



*Pic.3.5 Discharge Prints on Red Background*

A yellow polka dot on a blue background can be made by first dyeing the fabric “Blue” then printing with a yellow vat dye mixed with the colour-removing chemical.

Discharge print can be made by roller & screen methods, but not by heat transfer printing.

Discharge Prints are not widely used due to following reasons :

- Production is more costly than direct print because fabric is to be dyed prior to printing.
- Very careful and precise process control is required.

Developments of automatic rotary screen-printing, high quality blotch prints, which can produce the same effect at lower cost.

### Identification of Discharge Prints

- The background is the same shade on the face and back of the fabric (piece dyed).
- Print design area is white or a different removing or shade than background.
- Back of the print design reveals traces of the background removing.

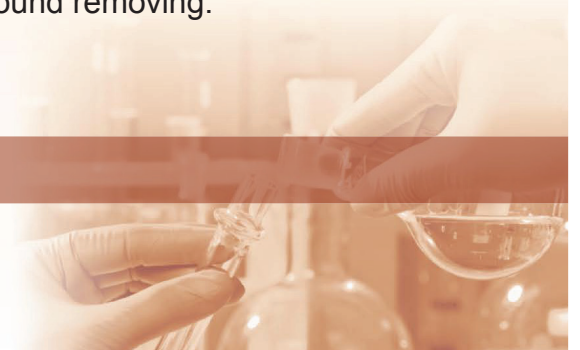





*Pic.3.5.1 Discharge Printed Fabric*

### 3.10 Resist Prints

In this type of prints, the fabric is printed in two steps. In first step, pattern or design is printed on a white fabric with a chemical (wax-like resinous substance) that will prevent or resist the penetration of dyes. In second step, the fabric is dyed by piece dyeing method.

Resist prints are not popular type of printing on fabric. It is generally used where removing of background colour from the fabric is very difficult. It is performed as craft or hand printing rather than on production basis. Generally used for Batik prints, tie-dye prints and ikat prints.



*Pic.3.6 Resist Printed Fabric*

### 3.11 Pigment Prints

Pigment prints are called direct prints. In this type of prints, Pigments are used as colouring matter compare to dyes. After printing with pigments, it does not require washing of the fabric, hence it is also called dry printing.

#### Identification of Pigment Prints

- Comparing the differences in fabric stiffness between a designs printed portion and a non-printed portion of the same fabric. The pigment print area will be slightly stiffer and a bit thicker than the non-print area.
- Deep shades are stiffer than light shades.
- Pigment prints are least costly.

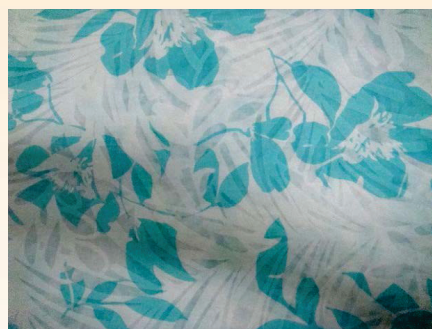

*Pic.3.7 Pigment Printed Fabric*



### Advantages of Pigment Prints

- Simple to apply
- Less amount of processing
- No after treatments are required (steaming & washing)
- Pigments produces bright and rich colors
- Can be applied to all fibers
- Good to excellent fastness to light and dry cleaning
- Widely used for drapery and curtain fabrics
- Excellent lot-to-lot shades matching attainable
- Colour removes gradually and become more faded with each laundering
- Poor fastness to crocking (rubbing) especially in dark colors.



*Pic.3.7 Pigment Printed Fabric*

### 3.12 Blotch Prints

In this type of printing, complete background has been obtained by printing. It is also called Direct Print. The print and pattern design color are printed on fabric in one printing operation that imitates the discharge or resist style of print effects.

#### Identification of Blotch Prints

- The blotch print background color is lighter on backside of the fabric.
- Possibilities of large background color areas of the print are not covered with full depth of colors.
- Precise control is necessary.
- If pigment are used in blotch prints, then fabrics very often result in objectionable stiff hand.





### 3.13 Flock Printing

In this type of printing, velvet like effect are produced on the printed surface. For this purpose, designs is first printed with adhesive and tiny particles of fibers (1/10" – 1/4") are made to adhere to a fabric surface in accordance with a particular design and then exposing the fibre flock adhere to the fabric at very high temperature.



*Pic.3.9 Mechanical Flock Printing*

There are two type of Flock printing:

1. Mechanical Flocking
2. Electrostatic Flocking

#### Mechanical Flocking

In this method of printing, the fabric is passed in open width through flocking chamber in which fibre flock is shifted on to the fabric surface while mechanical beaters cause fabrics to vibrate and flocks sticks on fabric.

#### Electrostatic Flocking

In this type of printing, Flock particles are given electrostatic charges, and passed though a high voltage chamber , Since all the flock are previously charged, all fibers orient in an upright position when they adhere to fabric. This is slower and more costly process. This method is generally used for rayon's and nylon fibers. The fibers are dyed prior to flocking to impart various colour to design. The ability of flocked fabric to withstand dry cleaning and washing completely depends on the quality & characteristics of adhesive.

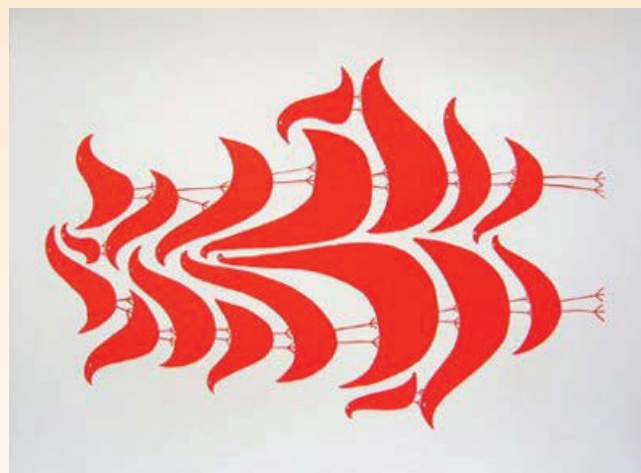

*Pic.3.10 Electrostatic Flock Printing*



### 3.14 Burn-Out Prints

This type of printing is normally carried out on polyester/ cotton , or polyester /Viscose blends. In this type of printing acid liberating substance (Ammonium Chloride, Aluminium Sulfate) are used. That substance will destroy the cotton or viscose fiber in the print area and printed portion will have mesh like structure; such types of prints are generally used in low-cost summer blouses and cotton lingerie. Interesting designs can be created with blends.



*Pic.3.11 Burn-Out Printing*

### 3.15 Duplex Prints

In this style of prints, Fabrics is printed on both the sides. This generally provides imitate Jacquard & Dobby woven pattern to the fabrics. It is very expensive printing.



*Pic.3.12 Duplex Printing*

### 3.16 Engineered Prints

This style of printing have two or more distinct designs and each of them is located in separate areas of the fabric, and each area is designed to become a specific part of the garment; such type of printing is called Engineered Prints. The fabric is generally printed by hand screen or heat transfer methods.



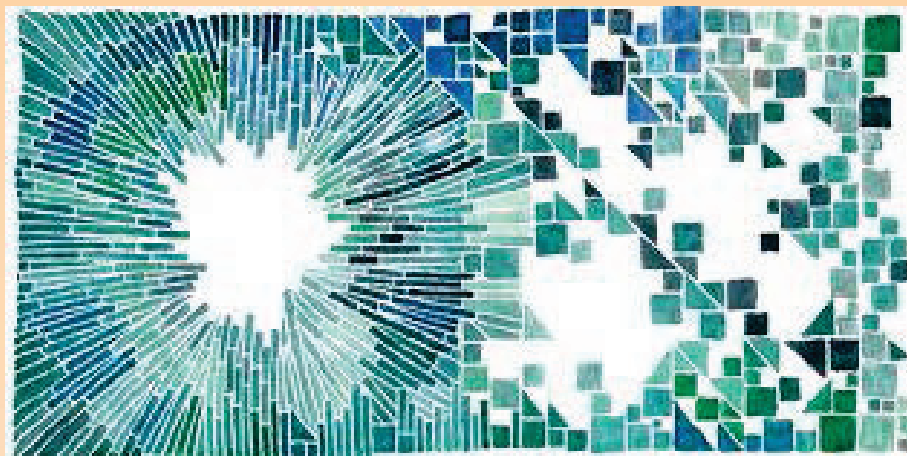

*Pic.3.13 Engineered Printing*

### 3.17 Warp Prints

Warp Prints involve printing the warp yarns of a fabric before it is placed on the loom for weaving, then, the fabric is woven with a solid color weft usually white or contrast color.

The result is a soft, shadowy design on the fabric. Producing warp prints require careful and skilled labor. These prints are found almost exclusively on high quantity and expensive fabrics.

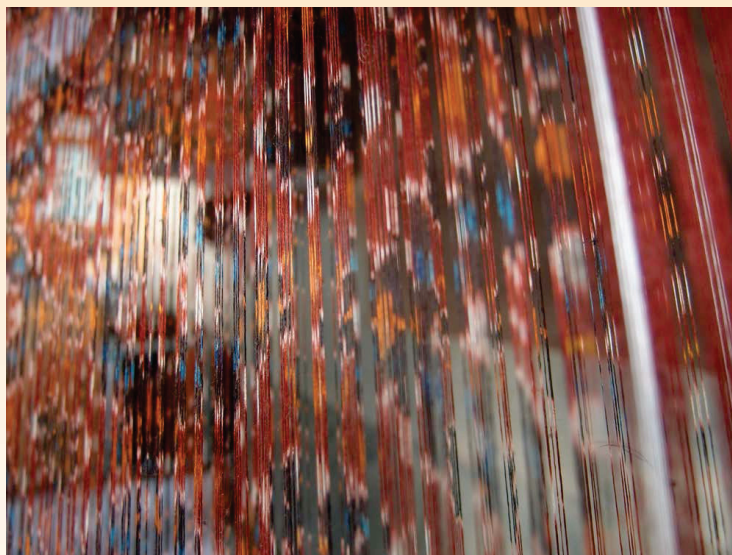

*Pic.3.14 Warp Printing (Patola Saree)*





## Exercise

### Fill in the blanks

1. ....is used to apply coloring localized areas only.
2. .... Best method for low yardage samples exclusive limited quality designs.
3. Half tone designs not possible in .....
4. Fine-line paisley prints not possible.....
5. Lengthwise stripe designs not possible.....
6. Large repeat size (up to 60") are possible in .....
7. Lengthwise stripe effect is possible in .....
8. Ability to print cut garment parts and small items is possible in .....
9. .... is also called an application print & most popular print types.
10. .... fabrics are dyed in solid color prior to printing & the design is applied by screen or roller with a chemical.
11. In..... production is more costly than direct print because fabric is to be dyed prior to printing.
12. The background removing is the same shade on the face and back of the fabric in .....
13. Batik prints, tie-dye prints and ikat prints are example of .....
14. In .....the area will be slightly stiffer and a bit thicker than the non-print area.
15. The .....background color is lighter on backside of the fabric.
16. Printing with chemical substance that will destroy the fibre in the printed area is called.....
17. Prints in which both sides of the fabric have been printed are called .....
18. Prints that have two or more distinct designs, each located in separate areas of the fabric, and each designed to become a specific part of the garment is called .....





### Short answer questions

1. Write down the limitation of the Screen Printing.
2. Write the Specific features of the Screen printing.
3. Write down the limitation and specific features of the Flat bed screen printing.
4. Write down the limitation and specific features of the Rotary screen printing.
5. Write down the limitation and specific features of the Heat transfer printing.
6. What are the specific features of Direct prints?
7. How do you identifies Direct print on the given fabric?
8. What are the specific features of Resist prints?
9. How do you identifies Resist print on the given fabric?
10. How do you identify the Pigment print on the given fabric?
11. How do you identify the Blotch print on the given fabric?
12. Write down the Specific features of the Following Prints
  - Flock Prints
  - Burn – Out Prints
  - Duplex Prints
  - Engineered Prints



## UNIT IV

### TEXTILE FINISHES

#### Learning outcome

After finishing this unit, students will be able to understand –

- Types of finishes and their performance.

#### Overview

This unit deals with the Textile Finishing. In this chapter students will be able to learn, the objectives of finishing and how these finishes will change the feels of the fabrics. They will also get to know about the special purpose finishes such as flame retardancy, water repellency, easy care etc. After completion of this chapter the students will be able to understand that what type of finishes are suitable to which kind of end use of the fabric.

### TEXTILE FINISHES

Finishing is the integral part of the textiles, without finishing fabrics can not be sold to the desired customer. Finishing is the sequence of operations, other than scouring, bleaching, and coloring, by which fabrics are improved in appearance and feel and provide desirable as well as essential properties. Fabric coming directly from the loom is unattractive. To make the fabric attractive and acceptable to the consumer several finishing processes are applied. Sometimes special finishes are also applied to the fabric to make it serviceable for particular operations. Following are the objectives of finishing operations.

#### Objectives of Finishing

The objectives of finishing are:

- To improve the appearance of the fabric, that is, to make it more attractive by operations like calendaring, optical whitening
- To improve the feel of the fabric by softening, stiffening
- To cover faults in the original fabric
- To improve wearing qualities of cloth by making it shrink resistant, crease resistant or free from pills and soiling







- To make garments hold their shape and enable them to be worn without ironing.
- To impart special properties to the fabric for specific end uses (eg. flame retardant, water repellent).
- To set the texture of certain fabrics and make them dimensionally stable.
- To produce stronger and more durable fabrics.

### Selection of Finishes

Selection of the finishes generally depends on the following factors:

- Contains of fabrics which means type of the fiber and yarn used in the fabrics
- Thread count (Total no of yarns presents in the one square inches of fabric)
- Method of fabric construction
- Hand, weight, drapability qualities
- End use of the fabric or garment

Finishes are generally classified by different persons into different category, which are briefly explained below

#### 4.1 Classification of Finishes

- According to Designer / Merchandiser / Sales Personals
  - Aesthetic Finishes
  - Functional Finishes
- According to Textile Chemist
  - Mechanical Finishes / Dry Finishes
  - Chemical Finishes / Wet Finishes
- According to Degree of performance
  - Permanent Finishes
  - Durable Finishes
  - Semi Durable Finishes
  - Temporary Finishes



### According to Designer / Merchandiser / Sales Personals

#### 4.1.1 Aesthetic Finishes

Aesthetic finishes are the finishes which change or modify the appearance and / or hand of the completed garment and gives fabrics a distinct surface effect which are pleasing to hand and eye. for examples improving the softness of fabric.

#### 4.1.2 Functional Finishes

Functional finishes are the finishes, which alter or improve the wear ability and performance of fabric or garment and provide for: Additional comfort, Safety measures, Environmental and Biological resistance, Durability for wear life of garment, improved care performance. Some of the example of such finishes are

- I. Encapsulated finishes
- II. Smart textiles
- III. Anti-Static
- IV. Moisture management
- V. Odor free
- VI. Non ironing
- VII. Anti-microbial
- VIII. UV absorbers
- IX. Cool finish
- X. Water proof finish and many more

#### 4.2 According to Textile Chemists

##### Mechanical Finishes / Dry Finishes

Such type of finishes generally causes a physical change in the fabric. These finishes are applied by mechanical equipment such as copper plates, drying cylinders, perforated cylinders or stenter frames. Generally temperature, Pressure and Steam are used during the mechanical finishes . Fabrics are handled in dry state hence these type of finishes are also called mechanical finishes.





### Chemical Finishes / Wet Finishes

In such type of finishing Acids, alkalis, bleaches, detergents, softeners, resins and other chemical substances cause a reaction and produce permanent change in fiber, yarn or fabric. These finishes are generally permanent in nature. Mercerization is the example of a chemical finishes.

#### 4.3 According to Degree of Performance

This type of classification is based on numbers of wash cycles

##### Permanent Finishes

This type of finish Involve a chemical change in the fiber structure. Once it is applied on the fabric, it will not change or alter throughout the life of fabric. Effectiveness of the finish will withstand throughout the life of the garment / fabric. Water proofing of umbrella fabric is the example of this type of finish.

##### Durable Finishes

Such type of finishes usually last throughout the life of the garment. However, Effectiveness of such finish will withstand for 50 – 60 cleanings. Near the end of the normal use life of the garment, the finish is completely removed. Softness of terry towel belongs to this class.

##### Semi Durable Finishes

Majority of finishes available in the market belongs to this class. Such types of finishes Last through 25 – 30 launderings / dry cleaning. Many of such finishes are renewable type and can be carried out during home laundering / dry cleaning.

##### Temporary Finishes

Such type of finishes is provided to the fabrics to add body or to improve appearance or hand of the fabric. Some time to increase the salability of inferior fabric. Such types of finishes are removed completely in 1 – 2 laundering or Dry Cleaning operations.

#### 4.4 General Finishes

##### Calendaring

In this finishing operation, fabric is compressed between two heavy rolls to provide



flattened, smooth appearance of fabric by the action of heat and pressure. Surface of the roller can be either smooth or engraved. These rollers are generally made of hardened chromium plated or elastic thermoplastic materials.

**Calendaring is done for many purposes. The main effects are as follows:**

- To improve the Smoothness of the fabric
- To increasing the luster of fabric
- For closing the threads of woven fabric
- For decreasing the air permeability
- For increasing the fabric opacity
- To improve the fabric handle
- To flatten the slubs
- For obtaining silk like / high gloss finish
- To obtain Surface patterning by embossing
- Consolidation of non-woven fabrics

### Swissing or Normal Gloss

This is a cold calendar process which produces a smooth and flat fabric –the steel bowl of the calendar is heated thus produces lustrous fabric. If a 7-bowl calendaring is used then the result is smooth fabric with surface gloss on both sides of the fabric.

### Chintz or Glazing or Friction Calendaring

This type of calendaring gives highly polished surface like Glazed Chintz Cotton fabric. If a very high gloss is required, then fabric is pre-impregnated with a wax emulsion and calendaring is carried out. If the fabric is pre-treated with resin then this is a semi-durable type of finish.

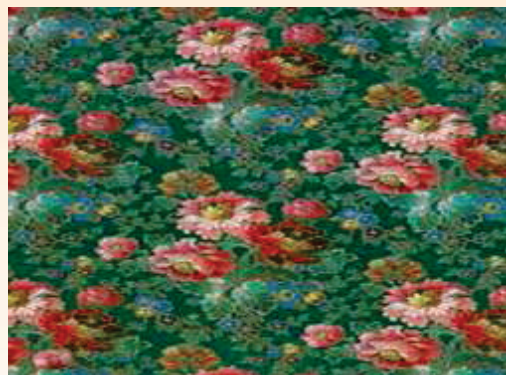

*Pic.4.1 chintz*

### Cire Calendaring

This is a Three-bowl calendaring where top bowl





rotates with much greater than friction calendaring (400 rpm). The resultant fabric becomes highly lustrous. Fabrics of cotton, rayon, polyester, nylon and blends may be given cire finish. The fabrics are pre-treated with wax or resin, to get highly polished effect. When synthetics are cire finished, the fabrics become moderately water-repellent due to flattening or partially fusing of fabric.

### Embossed Calendaring

It produces three-dimensional design on fabric. Embossing calendar consists of heated hollow metallic roller engraved with the embossing design and solid paper roller, twice the size of engraved roller. Fabric is drawn between the two rollers and designs are embossed on the fabric surfaces. If Celluloses fabrics are used for embossing purpose then effect will be temporary finish, however, Celluloses pre treated with resin will provide Semi durable embossing effect.

Permanent embossing can be achieved on the Synthetic fabrics

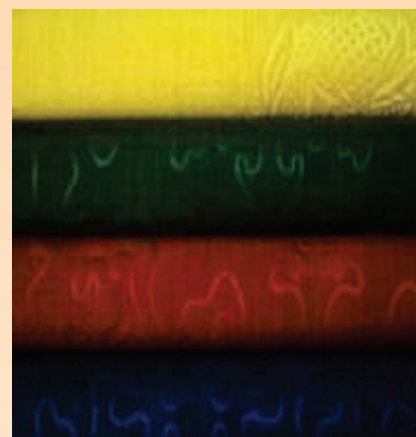

*Pic.4.2 Embossed Fabric*

### Moiré Calendaring

Produces wood grain design on the face side of the fabric. There are two ways to achieve this result.

#### Method One:

Rib fabric (Faille / Taffeta) and balanced plain weave fabric are placed face to face. Both the fabrics are fed into smooth heated metal rolls for calendaring keeping the speed of the rib fabric greater than that of the plain woven fabric. The pressure on the calendar rolls is maintained at about 8 – 10 tons

The result is undefined watermark or moiré effect is formed on rib woven fabric



*Pic.4.3 Moiré Pattern*



### Another Method of Embossing:

In this method, Embossed moiré pattern are engraved on the metal roll. When the roll passes over a Rib fabric, the ribs are flattened and a moiré pattern is created.

If Celluloses fabrics is used for embossing then temporary effects are achieved, However Celluloses or blends pre treated with resin will give Semi Durable finish. Permanent embossing effect can be obtained on the Synthetic fabrics.

### Schrenier Calendaring

This type of calendaring produces low, soft, smooth and luster on the fabric. 3-bowl calendaring is used to produce this effect, in this type of calendaring top metal roller are engraved with 200-300 fine diagonal lines per inch. This finish scatters light rays and produces a deep-seated luster rather shines. It can upgrade low quality cotton fabric. Also produces a softer hand and improved fabric cover. If Celluloses fabrics is used for embossing then temporary effects are achieved. However, Celluloses or it's blends, when pre treated with resin will give semi durable finish. Permanent embossing effect can be obtained on the Synthetic fabrics.

### 4.5 Napping / Brushing

This is Mechanical finish used for woven or knitted fabrics. To provide napping, fabric should be made from medium twist warp, and low twist weft yarn.

In this finish, fabrics are passed against rotating bristled wire covered rollers. Thereby distorting the weave of the fabric and raising the fibers from fabric surface. Example: Cotton, Woolen, Rayon, Melton, Wool Fleece flannels etc (Plain weave).

This provides softer hand and better insulation to the fabric; such finishes is widely used in blankets, sleep wear and winter clothing. The main drawback of Napped fabrics is that, these fabrics are more prone to pilling in particularly sleeve ends, coat fronts, buttonholes, elbows and other rubbing areas.



*Pic.4.4 Napping roller*





### 4.6 Emerizing, Sueding, Sanding or Peach Finish

This is a mechanical type of finish which produces soft and smooth / silky feel to the fabric. The fabric moves at a speed of 15–20 meters / minute under two or more rollers with fine emery paper on first roller to more abrasive paper in each successive roller. This process abrades the surface causing fibrils to split from the fibres. High abrasion and coarse abrasive sheet causes damage to fabric strength. Abrasion generate heat may cause harshness on synthetic fabric.

Strength of the fabric are generally decreases the by 60% in this process. Dry cleaning is preferred for this fabric. Emerizing can be applied to Polyester/Cotton, Polyester/Nylon blends, and 100% Polyester, Nylon and Micro denier synthetics. This finish is generally given to sportswear.



*Pic.4.5 Peach Finished Fabric*

### 4.7 Parchmentising or “Organdy”

This is the process in which cellulosic fabric are treated (fine count light weight) with concentrated Sulfuric acid which produces beautiful transparent and stiffer fabric. The action of Sulfuric acid produces different effects depending on its strength of the Acid and duration of treatment. The degree of luster and interesting surface effect can be obtained depending on pre-treatment of bleaching and mercerization of cotton fabric. Fancy and novel effect is obtained by well bleached and mercerized fabric. Embossed calendared cotton when treated with Sulfuric acid provides damask effect.

### 4.8 Functional Finishes

Functional finishes or special purpose finishes are applied to textile materials to enhance their performance properties in a specific area. Although these finishes do not changes the appearance of textiles they do address some consumer problem or make the textile substrate suitable for a specific purpose. Functional finishes generally govern the surface properties of the textile fibers such as adhesion property and optical appearance of the substrate.



Some of the functional finishes are listed below

- Encapsulated finishes
- Smart textiles
- Anti-static
- Moisture management
- Odor free
- Non ironing
- Anti-microbial
- UV absorbers
- Cool finish
- Water proof finish and many more

### Shape Retention Finishes

It is an essential property of a garment to retain its shape. Apparel products must retain their shape and pleats same even after many wearing, washings and dry cleaning . Such type of finishing are called“ Durable Press / Wrinkle Free / Wrinkle Resistant and Permanent Press”.

Wrinkles are due to pressure on the fabric during day today use and care. These finishes are used on cotton, rayon and linen because these three fibres wrinkle easily. In these finishes the fabric is treated with resin and then the resin is cured at higher temperatures. After this finishes fabric becomes stiffer, less absorbent and more resistant to wrinkling. Resin treatments also results in loss of tensile strength and reduction of abrasion resistance in cellulosic fibres. Most of these finishes are durable in nature.

Wrinkle recovery depends on ‘Cross Linking’ of the resin in the inner molecular structure of fibre. ‘Cross Links” which hold adjacent molecular chain together and pull them back in to position after the fibre is bent, Thus preventing the formation of a wrinkle. Fibres with strong inter molecular bonds have good molecular memory and they resist wrinkling. Fibres with weak bonds wrinkle easily.

Resin like Dimethylol Dihydroxy Ethylene Urea (DMDHEU) – Modified glyoxal based Poly Carboxylic Acid derived (Recent development) are generally used in the Durable Press finishes.







There are two type of process for the application of Durable Press Finish

- Pre- Cured Process
- Post – Cured Process

Both the process are described in detail,

### **Precured process of Durable Press**

#### **Application Procedure**

1. Treat the fabric with resin and dry.
2. Cure the fabric in curing chamber to form cross-linking between molecular chains.
3. Cut and sew the products and press

**General advantage and disadvantages are given in the table below.**

#### **Disadvantages**

1. No permanent creases
2. Puckered seams
3. Strength loss
4. Abrasion sensitive

#### **Advantages**

- Smooth fabric
- Dimensionally stable
- Lowest cost

Such finishes are used for shirting, draperies and other items that do not require pleating such as (Curtains, Bed sheets). This finishes are commonly given in Cotton / Polyester blends and can also be used for shaping the garments like (pants with a center crease).

Such garments are pressed with high temperature pressing equipment (Hot Head Pressers) to Heat sets the Polyester component.

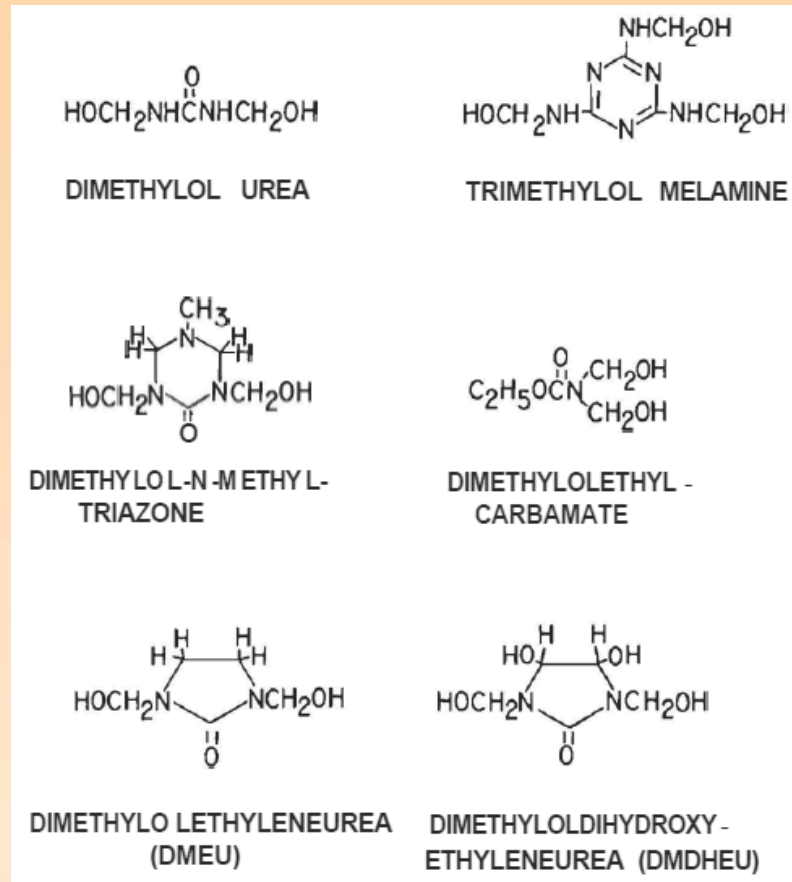

*Pic.4.6 Structure Of Chemicals Used in Durable Press Finish*

### Post Cured Process

- Treat the fabric with resin and dry.
- Cut and sew the product and press shape with Hot Head Press.
- Cure the pressed item in a curing oven at 300 – 400oF.

Advantages and disadvantages of the post cured process are given below.

### Advantages

- Post cured durable press finishes are Dimensionally stable
- Crease retention Properties of the durable press finishes are excellent
- Post cured durable press finishes fabrics shows Minimum Seam Puckering





### Disadvantages

- Higher Cost of production of Post Cure Durable Finish .
- Sometimes Post Cure Durable Finish May set prematurely
- Over finished areas of the Post Cure Durable Finish also increase the cost of the Fabric.
- Such finishes are Commonly used for Polyester/Cotton and Polyester/Viscose blends. The main reason to use of polyester blends is to compensate loss of strength and Abrasion resistance due to resin treatment on cellulose materials.
- This is a Durable finish and generally last for 40 – 50 laundering .

If Durable Press Finish is given to 100% Cotton fabrics, then specially constructed fabric and modified techniques are required to reduce the resin induced loss , abrasion resistance and tensile strength. For this purpose long staple cotton with tightly twisted yarns and compactly constructed (more yarns per inch) is required. This provides Semi durable effect which last for 15 – 20 laundering cycle.

### Special Problems of Durable Press Garments

**Frosting:** In these defects, localized color change takes place at creases, cuffs, collars and elbows area. Repairs or Alterations is difficult in durable press Garments, When seams are opened, It creases are impossible to remove.

### General Care Guidelines of Durable Press Garments

- Resins have a strong affinity for oil and grease stains; hence to avoid stains, immediately spot removal agents should be used
- Pre-treat stains at collars and cuffs areas to avoid the longer wash cycle
- Keep wash loads small to minimize wrinkling
- To avoid wrinkles to set, keep washing and drying temperature at optimally low
- Remove items promptly when dry

### Shrinkage Control Finishes

During the manufacturing process, Yarn passes through various types of stress and strain and further in the processing operations fabrics is also passed through various tensions, hence the fabrics has the tendency to shrink in daily uses, washing and relaxation process.



A reduction in the length or width of a fibre, yarn or fabric is known as shrinkage. Growth occurs when a fabric increases in dimension. It is essential to know the shrinkage of the fabrics in both the directions ( Warp wise and weft wise) to determine construction and design of garment.

### Causes of Shrinkage

There are various factors which contribute in the shrinkage process.

- Intermolecular structure of fibres
- Yarn twist
- Fabric construction (Yarns / inch)
- Weave / knit structure

Woven fabrics generally shrink more in the warp directions than in the weft direction because the warp yarns are under excessive tension during weaving. When the fabric is latter subjected in to wet treatment or heat treatment in the case of synthetic fibres, the stress and strain within the fibres are relieved, and the fabric relaxes.

Fibres that are moisture absorbent absorb water and swell. Accordingly, the yarn diameter increases, and the yarns in each direction must move closer together to accommodate the yarns in the opposite direction and results in increase the crimp of weft yarns.

Knit fabrics tend to stretch more during production than woven fabrics, and therefore knit fabrics are likely to shrink more than woven fabrics.

In commercial dry cleaning process, the procedures and solvents used ,do not permit fabrics to relax, as washing does, so that garments that are dry-cleaned may not shrink as readily. Shrinkage in dry cleaning generally results from the high moisture content in the solvent or from steaming during pressing of the fabric .

### Classification of Shrinkage

According to the behavior of the fabrics under various conditions, shrinkage of the fabrics can be classified into four main category.

- i. Relaxation Shrinkage
- ii. Progressive Shrinkage
- iii. Residual Shrinkage
- iv. Compressive Shrinkage





### Relaxation Shrinkage

Relaxation Shrinkage occurs due to the fibres and yarns are under considerable tension, during weaving, knitting and wet processing, the fabric undergoes stress and strain due to tension. Later when fabric becomes wet or steamed in a tension less condition, the stresses and strains are relaxed. Relaxation shrinkage occurs when fabric is laundered at initial stages.

### Progressive Shrinkage

Progressive Shrinkage occurs each time a fabric is laundered. This continuous shrinkage is due to the surface scale of the wool fibre, which also causes felting. In case of viscose rayon this continuous shrinkage is mainly due to high absorbency and swelling nature.

### Residual Shrinkage

Even after fabrics have been properly pre-shrunk in finishing, there is a small amount of shrinkage potential still remaining. This shrinkage is called residual shrinkage.

Some times extension of the of the fabric is also observed, during relaxation process ,this term is referred as growth of the fabric. This is result of the excessive shrinkage is given to the fabric during the pre shrinking process.

## 4.9 Shrinkage Control Methods

### Compressive Shrinkage (Sanforization)

This is a shrinkage control method, in which a sample of fabric is measured, the measurements are recorded, and the fabric is laundered such a way as to produce maximum shrinkage. The shrunken fabric is measured, and percentages of shrinkage are calculated in warp and weft direction. This indicates, the amount of compression to be given to the



*Pic.4.5 Peach Finished Fabric*



fabric so that fabric can become Anti - shrink.

In Compressive Shrinkage process, the fabric is dampened and is placed on a machine equipped with a continuous thick woolen felt blanket. The blanket travels around a smaller roller carrying the fabric with it as it stretches around the curve of the roller. As the carrier moves from the curve to a straight area, it compresses in to a smaller, flat area. When the carrier compresses, the fabric it carries is also compressed and is then heated to set in this compressed configuration. This process is also called Sanforization. When Compressive shrinkage is applied on the fabrics and fabrics does not shrink in any directions during relaxation process then this is called Zero – Zero Finish. This is very difficult to achieve during the processing.

### Shrinkage Control for Wool

Wool and animal hair fibers are among those few fibres that show progressive shrinkage. This continuous shrinkage is due to the scale structure of the woollen fiber, which also causes felting in the fabrics.

In addition to felting shrinkage, wool fabrics display the same type of residual shrinkage from relaxation that other fibres show. Unlike cotton fabrics, however, wool may continue to shrink if the relaxation of the fibres is not complete after one or two washings.

Shrinkage treatments for wool are of two types: those that minimize the problems of relaxation shrinkage and those that eliminate felting shrinkage.

### Decating or Decatizing

This is stress relaxation process of woolen fabrics. In this process, wool fabric is wound on a perforated cylinder, with a blanket of another fabric between those layers. Jets of steam are released through the holes in the cylinders, causing the fabric to be dampened and relaxed. Cold air is then blown through to set the fabric. Not only does this process set the wool fabric, but it also increases its luster. This is Mechanical type of finishing.



*Pic.4.8 Decatizing Machine*



#### 4.10 Soil Release / Stain Proof / Stain Repellent Finishes

This type of finish Improve the resistance to soil during the day to day use of the fabric and provide easy releasing of soil during the washing operations and prevent the soil to redeposit on the fabric and retaining whiteness or the original colour of fabric .The Soil Release Finish reduces the degree of soiling of the fabrics by:

- Repelling the soil
- Preventing formation of bond between soil and fabric
- Following chemicals are commonly used and applied by pad system
  1. Silicone
  2. Pyridinium
  3. Fluoro carbon
  4. Fluoro Carbon / Pyridinium
  5. Wax and metallic salt

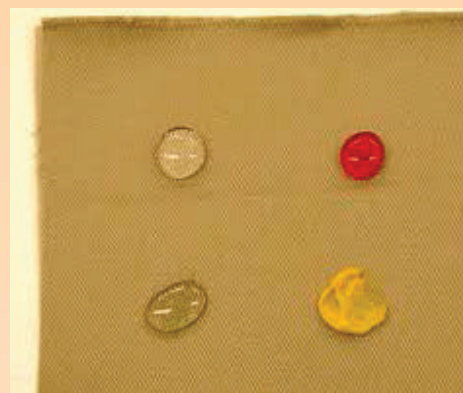

*Pic.4.9 Water & Soil Repellent Finish chemical based finishes*

|  |                             |
|--|-----------------------------|
|  | Durable                     |
|  | Durable                     |
|  | Durable                     |
|  | Durable - Water / Oil borne |
|  | Semi durable                |

Mainly applied for P/C, P/V blends and resin treated fabrics. These finishes helps to improve wet ability – during laundering for easy removal of soils by action of detergents / agitation.

#### 4.11 Water Repellent / Water Proof Finishes

Water repellency depends on surface tension and fabric penetrability. Water repellent fabric resist wetting but air / moisture can penetrate. It is achieved by combination of fabric structure and finish.

Commonly used chemicals are:

- Paraffin Wax                                   =>                   Spray
- Paraffin Wax with Al or Cr Salt   =>                   Spray
- Pyridinum Salt                               =>                   Pad -> Dry -> Bake





- Reactive Silicon Resins           =>           Pad -> Dry -> Bake
- Fluoro Carbon Emulsion       =>           Pad -> Dry -> Bake

These chemicals fill the gaps between yarns in fabric.

Performance of repellency depends upon: Nature of fabric and Soaps / detergents in cleaning

### Water Proof Fabrics

This is a completely moisture proof fabric which provide protection under all conditions of wet weather. Fabric is coated or laminated with a film of natural or synthetic rubber or plastic such as Vinyl or Polyurethane. This is a permanent type of finish.

### Water Proof Breathable Laminated Fabric

Laminated fabric, consisting of extremely thin laminate (0.001 inch) made from Teflon (Poly Tetra Fluroethylene). It provides a water proof yet breathable fabric. The Laminate sheet contains over one billion extremely fine holes per inch. Laminate can be applied on to woven / knitted fabric.

**Applications:** Heavy duty, foul weather clothing's, special military protective clothing, rain wear, ski wear, golf suits, sports footwear linings, hospital drapes, mattress, tarpaulins, tents and sleeping bag covers.

### 4.12 Anti Microbial Finishes

This finish prevents growth of bacteria and odor-causing germs, prevent decay and damage from perspiration, control the spread of disease and reduces the risk of infection following injury. This finish is generally applied in intimate apparels, body-fit garments, jogging and exercise clothing, sportswear, shoe linings, hospital linen and carpets.



*Pic.4.10 Anti Microbial Finished Fabric*







### Chemicals Used Are:

1. Quarternary Ammonium Compounds
2. Zirconium Peroxides and N-halamines

Usually applied by padding; Semi durable finish => 20 – 25 launderings

A variety of terms are used to describe the antimicrobial finishes applied to fabric. These include sterilization, disinfectant, antiseptic, and fungistat, mildew-resistant and rot proof finishes.

### 4.13 Insect & Moth Control Finishes

This finish is mainly applied for Wool and Wool Blends. The Chemical finish Permethrin is applied at the scouring or dyeing stage. It is a Semi Durable Finish => 15 – 20 launderings.

The prime requirement of mothproofing agent is that it to be toxic to moths and beetles that attack wool, but it must not be toxic to human beings at concentration levels used for mothproofing.

### 4.14 Durable Flame Retardant

Durable flame retardant is chemical finishes, which react with or physically held on the surface of the fabric or within the fiber. These finishes must withstand laundering and other cleaning procedures throughout the expected life of the fabric. Durable flames retardant are generally organic compounds, which contain phosphorus, nitrogen and / or halogen (chlorine or bromine) or combination of these in the chemical structure.

Durable flame retardant finishes are applied to a fabric by a pad-dry-cure process.

The finish formulation usually contains the flame retardant chemical, a softener, a resin binder or cross-linking agent and catalyst.

### Fabric Flammability

Fabrics can be placed in different categories with regard to flammability.

- Flammable: Completely consumed when exposed to fire



- Flame Resistant: Chemically treated to resist the spread of the flame
- Flame Proof: Fabrics made of fibres that are inherently non-flammable
- Example: Glass, Kevlar, Nomex
- Factors: which Affect the Degree of Fabric Flammability
- Fibre content: More air spaces within the fabric to burn more easily; Light weight fabric: Low twist in yarn; Thin yarn; Low yarn / stitches per inch; Pile or napped surface

### 4.15 Fabric and Garment Washes

#### Chemical Washes / Acid Wash

In this process a chemical is added to the wash solution to alter fabric surface. Chemicals include alkalis, oxidizing agents, and others that are specific to the fibre being treated. These chemicals partially destroy the fibre and create and modify the surface configuration of fabric.

#### Acid Wash

In this case oxidative bleaching agent such as sodium hypochlorite or potassium permanganate is added during the washing. No acid is used for this process. However, to neutralize the colour of potassium permanganate, fabrics are treated with acid, hence it is called acid wash. In this process, colour of denim fabric destroyed and white background appeared so this processes is also referred as white wash or snow wash.

This technique is used to produce fashion denims, comfort polyester and washed silks.

#### Enzyme Washes / Bio Polishing

In this process, Cellulase enzyme is used that dissolves part of cellulose molecule, which permanently effect on surface of the fabric. The hand of the fabric becomes softer after this finish; It also removes surface fuzz and reduce pilling and Improves



*Pic.4.11 T-Shirts Bio Polish Finish*





moisture absorption and dye ability of the fabric. The main limitation of enzyme wash is that it decreases fabric weight and strength 5 – 10%. This finish is mostly used for cotton, rayon, tencel fabrics . If enzyme finishing is applied after fabric has been dyed with Vat / Sulfur or Pigment dyes than Stone Wash Effect can be produced on the fabric

### Stone Wash / Abrasive Washes

With abrasive washes, pumice stones or some other abrasive material is saturated with a chemical like potassium permanganate and tumbled with the fabric or garment for 30-60 minutes.

The abrasive material is removed and the chemical is neutralized in a bath; with fabrics like cotton, the abrasion is controlled by the length of time the fabric is treated and the style and type of stone used.

With fabrics like silk that are lighter weight, the excessive abrasion may damage the fabric by tumbling.

Fabrics finished in this manner are referred to by a variety of fashion terms including stone washed denim, sanded silk, golf washed cotton and mud washed silk.

### 4.16 Micro Encapsulated Finishes

Micro capsules are between 5 – 50 microns and may contain fragrance, insect repellents, disinfectants, cleaning agents or activated charcoal Micro capsule are sprayed on to a fabric and held in place with Poly Vinyl Alcohol or Acrylic binder

Fragrance Finish is generally applied in : Handkerchiefs, Scarves, Curtains, Fur, Women's hosiery, Sweaters and T- shirts; Normal rubbing during wear rupture the capsules and release the fragrance



*Pic.4.12 Stone Wash Denim*



Moth Protecting agents have micro capsulated for application to wool products. Micro capsules containing bactericidal agents are applied to socks underwear, women's intimate apparel and active wear.

Activated charcoal is used as a deodorant finish to absorb body odor for gym wear active sports wear, intimate apparels and hunter clothing.

### Exercise

#### Fill in the blanks

1. Finishes that are applied by mechanical equipment such as copper plates, drying cylinders, perforated cylinders or stenter frames are called .....
2. A chemical substances that cause a reaction and produce permanent change in fibre, yarn or fabric are called .....
3. The finishes that involve a chemical change in the fibre structure & will not change or alter throughout the life of fabric is called .....
4. Effectiveness of .....will withstand for 50 – 60 cleanings.
5. ....last through 25 – 30 launderings / dry cleaning.
6. ....are removed completely in 1 – 2 laundering / Dry Cleaning.
7. .... produces 3-dimensional design on fabric.
8. .... occurs when fabric is laundered at initial stages.
9. .... occurs each time a fabric is laundered.
10. .... are among those few fibres that show progressive shrinkage.
11. In ..... process, wool fabric is wound on a perforated cylinder.
12. .... improve in resistance to soil / releasing soil and retaining whiteness of fabric.
13. .... depends on surface tension and fabric penetrability.
14. Water repellent fabric resist wetting but ..... can penetrate.
15. .... prevents growth of bacteria and odor-causing germs.
16. Insect & Moth Control finishes are mainly applied for .....





17. Durable flame retardant finishes are applied to fabric by a .....process.

### Short answer questions

1. Classify the textile finishes as per Textile Designers.
2. Classify the textile finishes as per the Degree of performance.
3. Write Short notes on
4. Calendaring.
5. Swissing
6. Friction Calendaring
7. Cire Calendaring
8. Embossed Calendaring
9. Moiré Calendaring
10. Schrenier Calendaring
11. Emerizing, Sue ding, Sanding Or Peach Finish
12. Parchmentising “Organdy”
13. Compressive Shrinkage (Sanforization)
14. Soil Release / Stain Proof / Stain Repellent Finishes
15. Anti Microbial Finishes
16. Fabric and Garment Washes
17. Micro Encapsulated Finishes



## Glossary

- Singeing:** Removal of protruding fibers from both sides of fabric by Burning.
- De-sizing:** Removal of starch from fabric.
- Scouring:** Cleaning treatment in which oil, waxes and residual sizes are removed from the fabric by the chemicals.
- Bleaching:** Removal of natural coloring matter and makes the fabric in perfect white.
- Mercerization:** Treated with a cold concentrated solution of sodium Hydroxide.
- Solution Dyeing**  
**“Dope Dyeing”**  
**“Mass Coloration”:** Manufacturing process of Man made fibers in which the coloring agents are mixed to polymer solution of man made fiber before it is extruded through a spinneret.
- Melange yarns:** ‘Heather-like effect’ for woolen yarns.
- Cross Dyeing:** Yarn, fabric or even garment made with two or more generic fiber types “Blends” having different dyeing qualities is dyed a single dye bath containing different classes of dyes.
- Union Dyeing:** Achieving single solid color on blended fabrics.
- Mudmee Tie-Dye:** Mudmee tie-dye is mainly created in Thailand and neighboring part of Laos. It uses different shapes and colors than other types of tie-dye, and the colors are, in general, more subdued.
- Batik:** Manual wax-resist dyeing technique.
- Resist Dyeing:** Prevent the dye from reaching all the cloth.
- Curing:** Treatment with high temperature.





# Textile Chemical Processing

Practical Manual

Class XII



**UNIT - I : Pretreatments 82**

|                |  |    |
|----------------|--|----|
| Practical I.   | Desizing of Cotton Fabrics by Acid Desizing method and calculate the weight loss in the Process. | 82 |
| Practical II.  | Scouring of Cotton by Sodium Hydroxide and measure water absorbency and shrinkage.               | 83 |
| Practical III. | Bleach the Cotton fabric with the bleaching powder.  | 84 |
| Practical IV.  | Bleach the Cotton fabric by Hydrogen Peroxide  | 85 |
| Practical V.   | Degumming of the Silk  | 86 |
| Practical VI.  | Bleaching of the Silk with the Hydrogen Peroxide.  | 87 |

**UNIT - II : Textile Dyeing 88**

|                 |                                      |     |
|-----------------|--------------------------------------|-----|
| Practical VII.  | Dyeing of Cotton with Direct Dyes.   | 88  |
| Practical VIII. | Dyeing of Cotton with Reactive Dyes. | 90  |
| Practical IX.   | Dyeing of Cotton with Vat Dyes.      | 92  |
| Practical X.    | Dyeing of Cotton with Sulphur Dyes.  | 94  |
| Practical XI.   | Dyeing of Cotton with Azo Dyes.      | 96  |
| Practical XII.  | Dyeing of Wool with Acid Dyes.       | 98  |
| Practical XIII. | Dyeing of Wool with Reactive Dyes.   | 100 |
| Practical XIV.  | Dyeing of Silk with Acid Dyes.       | 102 |
| Practical XV.   | Dyeing of Nylon with Acid Dyes.      | 104 |

**UNIT - III : Textile Printing 106**

|                  |  |     |
|------------------|--|-----|
| Practical XVI.   | Tie and Dye of Cotton with Direct Dyes (Resist Print). | 106 |
| Practical XVII.  | Batik Print on the Cotton Fabrics (Resist Print).      | 108 |
| Practical XVIII. | Printing on the Polyester fabrics by Pigment Dyes.     | 110 |
| Practical XIX.   | Printing on Cotton fabrics by Naphthol Dyes.           | 111 |
| Practical XX.    | Printing on Cotton fabric with Natural Dyes.           | 113 |

**UNIT - IV : Textile Finishes 115**

|                |   |     |
|----------------|---|-----|
| Practical XXI. | Collect the sample of finished fabrics and describe the type of finishes it may have. | 115 |
|----------------|---|-----|







### Sample Practical Sheet

Name  
Subject  
Class  
Date  
Practical detail:

.....  
.....  
.....  
.....

Description and result

.....  
.....  
.....  
.....

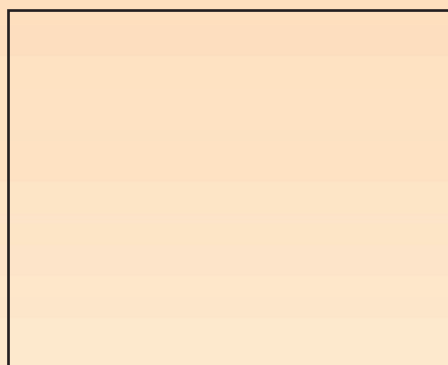
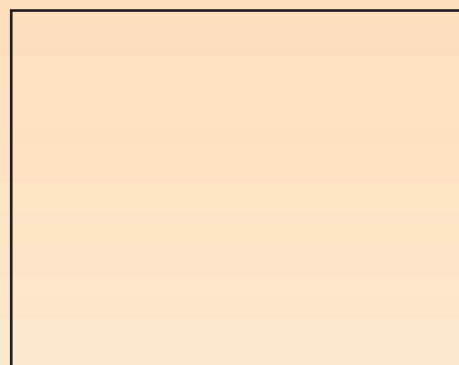

Teacher's Sign:





## UNIT - I : Pretreatments

### Practical - I

#### Objective

Desizing of Cotton Fabrics by Acid Desizing method and calculate the weight loss in the Process.

#### Materials /Chemical Required

Greige Cotton fabric/ Yarn, Hydrochloric Acid, Water

#### Procedure

- Take the oven dry weight of the given Cotton Fabric
- Wet it in the running water.
- Pour 2 % Hydrochloric Acid solution in dye bath .
- Put the fabric in the dye bath Solution.
- Temperature of the bath should be maintained 40°C.
- Gently stir the fabric at constant interval.
- Take the fabric out after two hours
- Wash the fabric though running water
- Allow it to dry in the Oven at 60°C.
- Take the oven dry weight of the Desize Fabric
- Calculate the weight loss by the Given Formula
- Iron the fabric and mount it on the sample layout sheet.

$$\text{Weight Loss} = \frac{\text{Oven Dry Weight of the Desize Fabric}}{\text{Oven Dry Weight of the Greige Fabric}} \times 100$$

#### Results

Given sample is having ..... % of starch materials





## Practical - II

### Objective

Scouring of Cotton by Sodium Hydroxide and measure water absorbency and shrinkage.

### Materials /Chemical Required

Desize Cotton fabric, Sodium Hydroxide, Soda ash, Wetting Agent and Water.

### Procedure

- Take a Cotton fabric of 20cm x 20cm size.
- Take oven dried weight of the fabric.
- Mark the fabric at distance of 10 cm in both direction (Warp and Weft).
- Soak the fabric in 3% Sodium Hydroxide solution.
- Add 1% Wetting agent to the solution.
- Maintain the material to liquor ratio 1:50.
- Raise the temperature up to 90°C.
- Maintain the temperature for 3 hours.
- Take the fabric out, wash it thoroughly, dried it and weight it.
- Measured the dimensional in both the direction and calculate percentage shrinkage and weight loss.
- Take a stripe of fabric of 2cm x 20cm size and suspend it vertically.
- Insert the stripe into water bath.
- Measure the time taken by water to rise up to 2.5cm up the stripe.
- This should be done before scouring as well as after scouring.
- Compare the result to determine the absorbency of fabric.
- Iron the fabric and mount it on the sample layout sheet.

### Result

- ..... % weight loss is observed.
- Shrinkage in Warp direction ..... %
- Shrinkage in Weft direction ..... %
- Measure the absorbency of the fabric by measuring the time in seconds before the scouring and after the scouring by putting a 2cm x 20cm size and suspend it vertically in water.



### Practical - III

#### Objective

Bleach the Cotton fabric with the Bleaching Powder

#### Materials /Chemical Required

Scoured Cotton Fabric, Bleaching Powder, Sodium Hydroxide, Hydrochloric Acid and Water.

#### Procedure

- Take desize and scour cotton fabric of 20cm x 20cm size and weight it.
- Prepare a water bath with 7-8 gram per liter bleaching powder
- Maintain 1:20 material to liquor ratio.
- Maintain the pH 11 with the help of Caustic Soda.
- Soak the fabric in the water bath for one hour at room temperature.
- Take the fabric out, squeeze it and rinse through running water.
- Soak it in the souring bath, containing 0.5 – 1 % of Hydrochloric Acid for 5-10 min.
- After souring wash the sample with cold water.
- Compare the sample with scoured cotton fabric.
- Iron the fabric and mount it on the sample layout sheet.

#### Result

Compare the whiteness of the fabric with desize, and soured fabric.





### Practical - IV

#### Objective

Bleach the Cotton fabric by Hydrogen Peroxide

#### Materials /Chemical Required

Scoured Cotton Fabric, Hydrogen Peroxide, Sodium Silicate, Caustic Soda and Water.

#### Procedure

- Take a Cotton fabric of 20cm x 20cm size which is previously desize and scoured.
- Prepare a water bath containing following recipe –  
Hydrogen Peroxide- 2%  
Caustic Soda – 2 %  
Sodium Silicate – 3%  
Material to liquor ratio 1:30.
- Take the calculated amount of solution in the pot.
- Enter the material into bath.
- Raise the temperature upto 90 degree centigrade.
- Maintain the temperature for 2 hours with continuous steering.
- Take the fabric out and squeeze it.
- Wash the fabric with running water.
- Iron the fabric and mount it on the sample layout sheet.

#### Result

- Compare the dried fabric with scoured fabric for whiteness.



## Practical - V

### Objective

Degumming of the Silk

### Materials /Chemical Required

Silk Cocum, Non Ionic Soap and water.

### Procedure

- Prepare a bath with following recipe –

|             |                |
|-------------|----------------|
| Soap        | 2 gram / liter |
| Soda        | 1 gram / liter |
| M: L ratio  | 1:40           |
| Temperature | Boil           |
| Time        | 1 hr           |
- Take silk cocoon or raw silk yarn/fabric of 20cm x 20cm<sup>2</sup> size for degumming.
- Weight the material and calculate the amount of liquor required for degumming.
- Soak the material into the solution and allow it to boil for two hours.
- Take the material out and wash it thoroughly in running water.
- Dried it and weight the degummed silk material.

### Result

Calculate the weight before and after degumming of silk and note the percentage weight loss.





## Practical - VI

### Objective

Bleaching of the Silk with the Hydrogen Peroxide.

### Chemical Required

Degummed Silk yarn or fabric, Hydrogen Peroxide, Sodium Silicate, Magnesium Chloride, Water.

### Procedure

- Take the degummed silk yarn or fabric of 20cm x 20cm size.
- Prepare the bath containing following recipes-

|                    |                |
|--------------------|----------------|
| Hydrogen Peroxide  | 5 gram / liter |
| Sodium Silicate    | 0.5%           |
| Magnesium Chloride | 0.02%          |
| M: L ratio         | 1:30           |
| Temperature        | 60°C           |
| Time               | 2 hours        |
- Take the weight of material.
- Take calculate amount of solution in the bath.
- Enter the material into the bath.
- Run the material for 2 hours maintaining the temperature 60°C.
- Take the sample out, squeeze it and rinse it in cold water.
- After drying is over , Iron the fabric and mount it on the sample layout sheet.

### Result

- Compare its whiteness, with the degummed silk material.



## UNIT - II : Textile Dyeing

### Practical - VII

#### Objective

Dyeing of Cotton with Direct Dyes

#### Materials /Chemical Required

Bleached Cotton Fabric, Direct Dyes, Water, Sodium Chloride and Sodium Sulphate.

#### Preparation of Stock Solution

- Weight accurately 0.5 gram of dye stuff.
- Paste it thoroughly with the help of water.
- Add small amount of hot water to the paste and dissolve it completely.
- If necessary solution can be heated till it becomes clear.
- Dilute the solution to 100 ml with cold water.
- This solution is called 0.5 % stock solution.
- From this solution, pipette out the calculated amount of dye solution.

#### Calculations:

$$\text{Amount of stock solution required in (ml)} = \frac{\text{Weight of fabric (gram)} \times \text{Shade \%}}{\% \text{ Shade of stock solution}}$$

Amount of water required = Weight of fabric x ML ratio – Amount of stock solution required

#### Procedure

- Take desize, scoured and bleached cotton yarn or fabric of 20cm x 20cm size.
- Weight it accurately.
- Immerse it into water bath for 10 minutes.
- Prepare stock solution separately.







- Take the calculated amount of stock solution.
- Add it into water bath.
- Maintain the material to liquor ratio 1:30.
- Slowly raise the temperature of water bath up to 90°C .
- Stir the dye liquor continuously for 20 minutes.
- Add calculated amount of sodium chloride to the dye bath.
- Increase the temperature up to boil.
- Continue dyeing for 20 more minutes.
- Add another calculated amount of sodium chloride solution to the dye bath.
- At the end of dyeing take the fabric out and squeeze and rinse it in running water.
- Soak the fabric or yarn in presence of 3 gram/liter soap solution and 2 gram/liter soda ash.
- Rinse the fabric in cold water and keep it for drying.
- When drying is over , Iron the fabric and mount it on the sample layout sheet.

### Result

- The given cotton fabric is dyed with the Direct Dyes ..... in ..... % Shade.



### Practical - VIII

#### Objective

Dyeing of Cotton with Reactive Dyes

#### Material/Chemical Required

Bleached Cotton Fabric, Water, Soda Ash, Sodium Chloride, Sodium Sulphate, Tri Sodium Phosphate.

#### Preparation of Cotton

- Take desize, scoured and bleached cotton yarn or fabric of 20cm x 20cm size.
- Weight it accurately.
- Immerse it in water bath for 10 minutes.

#### Preparation of Stock Solution

- Weight accurately 0.5 gram of dye stuff.
- Paste it thoroughly with the help water.
- Add small amount of hot water to the paste and dissolve it completely.
- If necessary solution can be heated till it becomes clear.
- Dilute the solution to 100 ml with cold water.
- This solution is called 0.5 % stock solution.
- From this solution pipette out the calculated amount of dye solution.

#### Procedure (A) :- Cold Brand Reactive Dyes

- Take the calculated amount of stock solution.
- Add it into water bath.
- Maintain the material to liquor ratio 1:30.
- Stir the dye liquor and enter the weighted cotton material.
- Raise the temperature up to 40°C.
- Run it for 10 minutes.
- Add calculated amount of common salt or glauber salt.



## Textile Chemical Processing – Class XII



- Continue dyeing for 30 more minutes.
- Stir the material frequently to obtain the even dyeing.
- Add calculated amount of Soda Ash.
- Continue dyeing for 60 minutes.
- At the end of dyeing, take the cotton fabric out squeeze it, and rinse with running water.
- Soak the fabric or yarn in presence of 3gram/liters soap solution and 2gram/liters soda ash.
- Rinse the fabric in cold water and keep it for drying.
- After drying is over , Iron the fabric and mount it on the sample layout sheet.

### Result

- The given cotton fabric is dyed with the Reactive Dyes ..... in ..... % Shade.



## Practical - IX

### Objective

Dyeing of Cotton with Vat Dyes.

### Material/ Chemical Required

Bleached Cotton Fabric, Sodium Hydroxide, Hydros, Wetting Agents (Terkey Red Oil) & Water, Hydrogen Peroxide .

### Calculations:

$$\text{Amount of stock solution required (ml)} = \frac{\text{Weight of fabric (gram)} \times \text{shade \%}}{\% \text{ shade of stock solution}}$$

Amount of water required = Weight of fabric x ML ratio – amount of stock solution required

### Preparation of Sample

- Take a desized, scoured & bleached cotton fabric of 20cm x 20cm size
- Weight it accurately
- Prepare 0.5% stock solution with standard method

### Wetting (Preparation of Stock Solution)

- Take 0.5 gram of dyes
- Paste it with Terkey Red Oil
- Add 2-3 gram of NaOH (Dissolved in small water)
- Add 2-3 gram of Hydro (Dissolved in water)
- Make the volume of solution 100 ml.
- If required then heat the solution up to 50°C
- Stock solution of 0.5% conc. is ready for dyeing

### Dyeing Procedure:-

- Calculate the amount of stock solution required.
- Maintain the M: L ratio 1.30 in water bath.





- Enter the cotton fabric in the dye bath
- Raise the temperature of bath up to 60°C
- Run the cotton fabric for 40 min.
- Maintain the level of caustic & hydro in the water bath (2-3%)
- Take the sample out & put the sample in for oxidation.

### Oxidation

- Prepare a bath with 2% HCl & 3% H<sub>2</sub>O<sub>2</sub> solution
- Enter the fabric in the oxidation bath & run it for 5 min.

### Soaping

- Take the sample out & run it in 2-3% soap solution for 20 min at 60°C.
- Take the sample out and rinse it thoroughly with water
- Keep the sample for drying
- When drying is over, Iron the fabric and mount it on the sample layout sheet.

### Result

- The given cotton fabric is dyed with the Vat Dyes ..... in ..... % Shade.



## Practical - X

### Objective

Dyeing of Cotton with Sulphur Dyes.

Dyeing of cotton with sulphur dyes consists of four steps.

- Dissolving of Dyes.
- Application of Sulphur Dyes
- Oxidation
- Soaping

### Material / Chemical Required

Bleached Cotton Fabric, Sulphur Dyes, Turkey Red Oil, Sodium Sulphide, Soda Ash, Common Salt/Sodium Sulphate, Sulphuric Acid, Potassium Dichromate, Acetic Acid & Soap.

### Preparation of Stock Solution:

#### Dissolving

- Take the calculated amount of Sulphur Dye (0.5 gram)
- Paste it with Turkey Red Oil
- Add 1 gram of Sodium Sulphate to the paste.
- Add small amount of warm water to the paste.
- Make it 100 ml with distilled water.
- If dye is not dissolved completely, heat the solution until it becomes clear.
- If there are still some turbidity in the solution than add small amount of hydro to the solution.

### Calculations:

$$\text{Amount of stock solution required (ml)} = \frac{\text{Weight of fabric (gram)} \times \text{shade \%}}{\% \text{ shade of stock solution}}$$





Amount of water required = Weight of fabric x ML ratio – amount of stock solution required

### Dyeing Procedure

- Take the calculated amount of dyes from stock solution
- Maintain the M:L ratio 1:30
- Run the pre wetted fabric in the dye bath
- Increase the temperature of dye bath up to 80°C
- Add sodium chloride in the dye bath in three installments during the dyeing process.
- Continue the dyeing for 60 minutes.

### Oxidation

- Prepare the oxidation bath with 3% Potassium Dichromate and 4% Acetic Acid (33%)
- Maintain the M:L ratio 1:30
- Immerse the dyed sample in to oxidation bath
- Increase the temperature of bath up to 60°C
- Continue the oxidation process for 10 minutes

### Soaping

- After oxidation, soaping should be carried out with 2gpl Soda Ash & 3 gpl Soap at 60°C for 20 min.
- Rinse with cold water and dry
- When drying is over , Iron the fabric and mount it on the sample layout sheet.

### Result

- The given cotton fabric is dyed with the Sulphur Dyes ..... in .....% Shade.



## Practical - XI

### Objective

Dyeing of Cotton with Azo Dyes

Dyeing of cotton fabric with Azo dyes consists of four steps.

- Dissolving of Naphthol
- Application of Naphthol on cotton fabric
- Development colour with base or salt
- Soaping

### Material / Chemical Required

Bleached Cotton Fabric, Water, Caustic Soda, Common Salt, Sodium Nitrate, Formaldehyde 40%, Sodium Acetate, Acetic Acid, Soap.

### Dissolving of Naphthol

- Take one gram of Naphthol
- Paste it with TRO (Terkey red oil)
- Add 0.6 gram of Sodium Hydroxide solution
- Add small amount of boil water
- Boil the solution until it becomes clear
- Dilute the solution to 100 ml

### Application of Naphthol

- Take desize, soured & bleached cotton fabric
- Immerse it into the Naphthol solution
- Add 3 gram of common salt to the solution
- Run the fabric into the solution for 20 min.
- Squeeze the fabric evenly
- Take the sample for developing the color







### Preparation of Base

- Take 1 gram of base
- Add 1 gram Sodium Nitrate & Water to it
- Add 1.5 ml of Hydrochloric Acid to the solution
- Add 1 gram of Sodium Acetate & 0.8 ml of Acetic Acid solution to it.
- Add 1 gram of Alum to the solution
- Make the volume of this solution to 50 ml

### Application of Base/Development Procedure

- Take Naphthol treated cotton fabric
- Run it through the base solution for 20 min
- Take the material out, squeeze and wash it
- Run the material in soap bath contain 5 gpl Soap & 2 gpl Soda ash
- Wash and dry the fabric
- When drying is over, Iron the fabric and mount it on the sample layout sheet.

### Result

- The given cotton fabric is dyed with the Naphthol Dyes ----- in -----% Shade



## Practical - XII

### Objective

Dyeing of Wool With Acid Dyes

### Material / Chemical Required

Wool Yarn or Fabric ,Acid Dyes, Formic Acid, Acetic Acid, Glauber Salt & Water.

### Preparation of Stock Solution:

- Weigh accurately 0.5 gram of dye stuff.
- Paste it thoroughly with the help of water.
- Add small amount of hot water to the paste and dissolve it completely.
- If necessary solution can be heated till it becomes clear.
- Dilute the solution to 100 ml with cold water.
- This solution is called 0.5 % stock solution.
- From this solution, pipette out the calculated amount of dye solution.

### Calculations:

$$\text{Amount of stock solution required (ml)} = \frac{\text{Weight of fabric (gram)} \times \text{shade \%}}{\% \text{ shade of stock solution}}$$

Amount of water required = Weight of fabric x ML ratio – amount of stock solution required

### Dyeing Procedure

- Prepare the 0.5% stock solution of acid dyes.
- Take the weight of the wool fabrics
- Calculate the amount of dye required as per the shade percentage.
- Prepare a dye bath with 1:30 ML ratio
- Run the sample in the dye bath for 10 minute



## Textile Chemical Processing – Class XII



- Run the fabric for 30 min at 80°C
- Add 2% (10 ml) Acetic Acid to the dye bath
- Run the fabric for 20 min at boil
- Add 10 ml of 2% Acetic Acid solution to the bath
- Run the fabric for another 10 min.
- Take the fabric out of water bath
- Rinse it thoroughly in the running water
- Dry the sample
- When drying is over, Iron the fabric and mount it on the sample layout sheet.

### Result

- The given Wool fabric is dyed with the Acid Dyes ..... in .....% Shade.



### Practical - XIII

#### Objective

Dyeing of Wool with Reactive Dyes

#### Material / Chemical Required

Bleached Wool Yarn Or Fabric, Reactive Dyes, Formic Acid, Acetic Acid, Glauber Salt & Water.

#### Preparation of Stock Solution

- Weight accurately 0.5 gram of dye stuff.
- Paste it thoroughly with the help of water.
- Add small amount of hot water to the paste and dissolve it completely.
- If necessary solution can be heated till it becomes clear.
- Dilute the solution to 100 ml with cold water.
- This solution is called 0.5 % stock solution.
- From this solution pipette out the calculated amount of dye solution.

#### Calculation:

$$\text{Amount of stock solution required (ml)} = \frac{\text{Weight of fabric (gram)} \times \text{shade \%}}{\% \text{ shade of stock solution}}$$

Amount of water required = Weight of fabric x ML ratio – amount of stock solution required

#### Dyeing Procedure

- Prepare the 0.5% stock solution of Reactive dyes.
- Take the weight of the wool fabrics
- Calculate the amount of dye required as per the shade percentage.
- Prepare a dye bath with 1:30 ML ratio





- Run the sample in the dye bath for 10 minute
- Run the fabric for 30 min at 80°C
- Add 2% (10 ml) Acetic Acid to the dye bath
- Run the fabric for 20 min at boil
- Add 10 ml of 2% Acetic Acid solution to the bath
- Run the fabric for another 10 min.
- Take the fabric out of water bath
- Rinse it thoroughly in the running water
- Dry the sample
- When drying is over, Iron the fabric and mount it on the sample layout sheet.

### Result

- The given Wool fabric is dyed with the Reactive Dyes ----- in -----% Shade.



### Practical - XIV

#### Objective

Dyeing of Silk with Acid Dyes

#### Material / Chemical required

Bleached Silk Fabric, Acid Dyes, Formic Acid, Acetic Acid, Glauber Salt & Water.

#### Preparation of Stock Solution

- Weigh accurately 0.5 gram of dye stuff.
- Paste it thoroughly with the help of water.
- Add small amount of hot water to the paste and dissolve it completely.
- If necessary solution can be heated till it becomes clear.
- Dilute the solution to 100 ml with cold water.
- This solution is called 0.5 % stock solution.
- From this solution pipette out the calculated amount of dye solution.

#### Calculations:

$$\text{Amount of stock solution required (ml)} = \frac{\text{Weight of fabric (gram)} \times \text{shade \%}}{\% \text{ shade of stock solution}}$$

$$\text{Amount of water required} = \text{Weight of fabric} \times \text{ML ratio} - \text{amount of stock solution required}$$

#### Dyeing Procedure

- Prepare the 0.5 % stock solution of acid dyes.
- Take the weight of the silk fabrics.
- Calculate the amount of dye required as per the shade percentage.
- Prepare a dye bath with 1:30 ML ratio.
- Run the sample in the dye bath for 10 minute.





- Add 5 gram of glauber salt to the solution.
- Run the fabric for 30 min at 80°C.
- Add 2% (10 ml) Acetic Acid to the dye bath .
- Run the fabric for 20 min at boil.
- Add 10 ml of 2% Acetic Acid solution to the bath.
- Run the fabric for another 10 min.
- Take the fabric out of water bath.
- Rinse it thoroughly in the running water.
- Dry the sample.
- When drying is over, Iron the fabric and mount it on the sample layout sheet.

### Result

- The given Silk fabric is dyed with the Acid Dyes ----- in -----% Shade.



### Practical - XV

#### Objective

Dyeing of Nylon With Acid Dyes

#### Material / Chemical Required

Bleached Nylon Fabric, Acid Dyes, Formic Acid, Acetic Acid, Glauber Salt & Water.

#### Preparation of Stock Solution

- Weight accurately 0.5 gram of dye stuff.
- Paste it thoroughly with the help water.
- Add small amount of hot water to the paste and dissolve it completely.
- If necessary solution can be heated till it becomes clear.
- Dilute the solution to 100 ml with cold water.
- This solution is called 0.5 % stock solution.
- From this solution pipette out the calculated amount of dye solution.

#### Calculations:

$$\text{Amount of stock solution required (ml)} = \frac{\text{Weight of fabric (gram)} \times \text{shade \%}}{\% \text{ shade of stock solution}}$$

Amount of water required = Weight of fabric x ML ratio – amount of stock solution required

#### Dyeing Procedure

- Prepare the 0.5% stock solution of acid dyes.
- Take the weight of the Nylon fabrics.
- Calculate the amount of dye required as per the shade percentage.
- Prepare a dye bath with 1:30 ML ratio.
- Run the sample in the dye bath for 10 minute.







- Run the fabric for 30 min at 80°C.
- Add 2% (10 ml) Acetic Acid to the dye bath.
- Run the fabric for 20 min at boil.
- Add 10 ml of 2% Acetic Acid solution to the bath.
- Run the fabric for another 10 min.
- Take the fabric out of water bath
- Rinse it thoroughly in the running water.
- Dry the sample.
- When drying is over, Iron the fabric and mount it on the sample layout sheet.

### Result

- The Nylon fabric is dyed with the Acid Dyes ----- in -----% Shade.



## UNIT - III : Textile Printing

### Practical - XVI

#### Objective

Tie and Dye of Cotton fabric with Direct Dyes ( Resist Print)

#### Material / Chemical Required

Bleached Cotton Fabrics, Direct Dyes, Water, Sodium Chloride, Sodium Sulphate.

#### Preparation Of Stock Solution

- Weight accurately 2 gram of dye stuff.
- Paste it thoroughly with the help water.
- Add small amount of hot water to the paste and dissolve it completely.
- If necessary solution can be heated till it becomes clear.
- Dilute the solution to 100 ml with cold water.
- This solution is called 2 % stock solution.
- Use this solution for Tie & Dye of fabric

#### Procedure

- Take desize scoured and bleached cotton yarn or fabric of 20cm x 20cm size.
- Tie the fabric by any one of the method taught in the classs (Folding, Pleating, Spiraling, Twisting, Coiling, Marbelling, Simple Tying or Tritik).
- Immerse it in water bath for 10 minutes.
- Prepare stock solution separately.
- Take the calculated amount of stock solution.
- Add it into water bath.
- Maintain the material to liquor ratio 1:30.
- Slowly raise the temperature of water bath up to 90°C.
- Stir the dye liquor continuously for 20 minutes.
- Add calculated amount of sodium chloride to the dye bath.



## Textile Chemical Processing – Class XII



- Increase the temperature up to boil.
- Continue dyeing for 20 more minutes.
- Add another calculated amount of sodium chloride solution to the dye bath.
- At the end of dyeing take the fabric out and squeeze and rinse it in running water.
- Repeat the entire procedure for getting the another color.
- For getting the various effects students may explore the time of exposure and position of the dipping, in the dye bath.
- Soak the fabric or yarn in presence of 3gram/liters soap solution and 2gram/liters soda ash to avoid the bleeding problems.
- Rinse the fabric in cold water and open the fabrics to see the effects of dyeing and keep it for drying.
- When drying is over, Iron the fabric and mount it on the sample layout sheet.

### Result

- The Cotton fabric is Tie and Dyed in various patterns.



## Practical - XVII

### Objective

Batik Print on the Cotton Fabrics (Resist Print)

Batik printing of cotton fabric with Azo dyes consists of five steps.

- Application of Wax on the Cotton Fabric.
- Dissolving of Naphthol.
- Application of Naphthol on Cotton fabric.
- Development Colour with base or salt.
- Soaping.

### Material / Chemical Required

Bleached Cotton Fabric, Water, Caustic Soda, Common Salt, Sodium Nitrate, Formaldehyde 40%, Sodium Acetate, Acetic Acid, Soap, Natural Wax & Paraffin Wax.

### Application of Wax on the Cotton Fabric

- Mix the Paraffin wax and Bee Wax in 60:40 Ratio.
- Put these mixture of wax in a utensil,
- Heat the mixture of wax until it melts completely. ( Melting temperature – Appox 70°C) Continue the heating the wax at lower temperature so that it will not solidify.
- Apply this wax on the cotton fabric with the helps of the brush
- When the application of wax is complete then put this sample in the Naphthol bath

### Dissolving of Naphthol

- Take one gram of Napthal.
- Paste it with TRO (Terkey Red Oil).
- Add 0.6 gram of Sodium Hydroxide solution.
- Add small amount of boil amount.
- Boil the solution until it becomes clear.
- Dilute the solution to 100 ml.





### Application of Naphthol

- Take desize, soured & bleached cotton fabric on which wax is applied.
- Immerse it into the Naphthol solution.
- Add 3 gram of Common Salt to the solution.
- Run the fabric in the solution for 5 min.
- Squeeze the fabric evenly.
- Take the sample for developing the color.

### Preparation of Base

- Take 1 gram of base.
- Add 1 gram Sodium Nitrate & Water to it.
- Add 1.5 ml of HCl to the solution.
- Add 1 gram of Sodium Acetate & 0.8 ml of Acetic Acid solution to it.
- Add 1 gram of Alum to the solution.
- Make the volume of this solution to 50 ml.

### Application Of Base/Development Procedure

- Take Naphthol treated cotton fabric.
- Run it through the base solution for 20 min.
- Take the material out, Do not squeezed the fabric and wash it and keep it for drying.

Repeat the entire process and develop the another colour by protecting the previous shade.

- Run the material in soap bath contain 5 gpl soap & 2 gpl soda ash and keep it boiling until and unless entire wax has not come out.
- Wash the fabric with cold water and dry the fabric.
- When drying is over, Iron the fabric and mount it on the sample layout sheet.

### Result

- The Cotton fabric is Resist Printed.



### Practical - XVIII

#### Objective

Printing on the Polyester fabrics by Pigment Dyes.

#### Material / Chemical Required

Bleached Polyester Fabric, Binder, Low Viscosity CMC, Urea, Water, Kerosene Pigment & Di Ammonium Phosphate.

#### Preparation of the Thickener

- Take 75 ml of kerosene.
- Add 6 gram of low viscosity CMC.
- Add 2 gram of urea.
- Add 7 ml of water.
- Add 10 gram of binder.
- Mix all this chemicals with high speed stirring.

#### Preparation of Printing Paste

- Take 90 gram of thickener.
- Add 4 gram of pigment.
- Add 3 gram of Di Ammonium Phosphate.
- Add 3 ml water.
- Stir well for uniform mixing.

#### Printing

- Print the fabric with the paste.
- Dry the printed fabric.
- Fix the print by the application of dry heat treatment at 140°C for 5 minutes by ironing or by dryer.
- When drying is over, Iron the fabric and mount it on the sample layout sheet.

#### Result

- The Polyester fabric is printed with Pigments.





## Practical - XIX

### Objective

Printing on Cotton fabrics by Naphthol Dyes.

Printing with Naphthol colour involve following steps

- Dissolving of Naphthol
- Application of Naphthol on cotton fabric
- Application of printing paste with base or salt
- Soaping

### Material / Chemical Required

Bleached Cotton Fabric, Water, Caustic Soda, Common Salt, Sodium Nitrate, Formaldehyde 40%, Sodium Acetate, Acetic Acid, Soap,

### Dissolving of Naphthol

- Take one gram of naphthal
- Paste it with TRO (Turkey Red Oil)
- Add 0.6 gram of Sodium Hydroxide solution
- Add small amount of boiled water
- Boil the solution until it becomes clear
- Dilute the solution to 100 ml

### Application of Naphthol

- Take desize, soured & bleached cotton fabric on which wax is applied.
- Immerse it into the Naphthol solution
- Add 3 gram of common salt to the solution
- Run the fabric in the solution for 5 min.
- Squeeze the fabric evenly
- Take the sample for developing the color



### Preparation of printing paste with Base/ Salt

- Take 77gram of thickener.

Separately dissolve the fast colour salt as per the recipe given below

- 5 gram of Fast color salt
- Add 1gram Sodium Nitrate & water to it
- Add 1.5 ml of HCl to the solution
- Add 1 gram of Sodium Acitade & 2 ml of Acetic Acid (50%) solution to it.
- Add 1 gram of alum to the solution
- Make the volume of this solution to 23 ml

Mixed this solution with the thickener with continuous stirring.

### Application of Base for Printing Procedure

- Take Naphthol treated cotton fabric
- Print the fabric with this paste.
- Keep it for drying
- Soap the fabric with 2gram / liter soap solution
- Rinse the fabric
- Wash the fabric with cold water and dry the fabric.
- When drying is over, Iron the fabric and mount it on the sample layout sheet.

### Result

- The Cotton fabric is printed with Naphthol colour.







## Practical - XX

### Objective

Printing on cotton fabric with Natural Dyes

Printing with Natural Dyes involve following steps

- **Fabric Preparation**
- **Application of Mordant on cotton fabric**
- **Dyeing with Natural Dyes**

### Material / Chemical Required

Bleached Cotton Fabric, Water, Alum , Ferrous Sulphate, Copper Sulphate, Herda Powder, Natural Dyes , Tamarind Seed Powder.

### Fabric Preparation

- Take 20 gram of Herda Powder
- Put it into 200 ml of water
- Put 20 X 20 cm Cloth into it for half an hour
- Dry the fabric in the shade
- Remove all the dusting of the Herda powder from the fabric

### Preparation of Mordant Paste

- Take 50 Gram of the Tamarind Seed Powder.
- Pour 40 ml of water with continuous stirring
- Add 20 Gram of Mordants ( Alum or Copper Sulphate or Ferrous Sulphate any one)
- Continue stirring the paste till it is mixed uniformly.
- Adjust the viscosity of the paste by adding the small amount of water
- Print the fabric with this paste and keep it for drying.
- Wash the fabric in the running water and remove all the paste.



### Dyeing

- Take 50 gram of the any natural dye (Termeric powder or Madder Root powder)
- Put it into the water and boil it
- Enter the printed cloth in this bath and continue boiling for one hour.
- Take the fabric out of the bath and rinse it with water.
- Put the fabric for drying
- When drying is over, Iron the fabric and mount it on the sample layout sheet.





## UNIT - IV : Textile Finishes

### Practical - XXI

#### Objective

Collect the sample of finished fabrics from the market and describe the type of finishes it may have. The main objective of this exercise is to Identify the various type of the finished fabrics are available in the market and to development the understanding the end uses of the given fabric. Student are expected to collect at least 20 sample of the different swatches and mount it in the sample sheet.



## Textile Chemical Processing – Class XII

