

B.Sc. COSTUME DESIGN AND FASHION**PRINCIPLES OF PATTERN MAKING & GRADING****CONTENTS**

LESSON NO.	TITLE OF THE LESSON	PAGE NO.
1	BODY MEASUREMENTS	
2	HEAD THEORY	
3	PREPARATION OF FABRIC FOR CUTTING	
4	TYPES OF PAPER PATTERNS AND METHODS OF PATTERN MAKING	
5	PATTERN MAKING - DRAFTING	
6	PATTERN MAKING - DRAPING	
7	STYLES CREATED USING DART MANIPULATION	
8	GARMENT FITTING	
9	PATTERN ALTERNATION	
10	PATTERN GRADING - MANUAL	
11	MASTER PATTERN GRADING	
12	PATTERN LAYOUT	
13	TRANSFERRING PATTERN MARKINGS AND FABRIC CUTTING	

LESSON – 1: BODY MEASUREMENTS

CONTENTS

- 1.0. Aims and Objectives
- 1.1. Importance of body measurements
- 1.2. Preparation for measuring
- 1.3. Ladies measurements
- 1.4. Boys and men's measurements
- 1.5. Standardizing body measurements
 - 1.5.1. Importance and techniques
- 1.6. Let us sum up
- 1.7. Lesson end activities
- 1.8. Points for discussion
- 1.9. References

1.0 AIMS AND OBJECTIVES

In this unit we have discussed the importance and how to take body measurements.

After reading this unit, you should be able to know

- How to take body measurements in different parts of the body

1.1 IMPORTANCE OF BODY MEASUREMENTS

In order to construct garments that fit well, body measurements must be taken with precision. You can draft original patterns based on these measurements which can be used as the basis of a variety of styles. You may buy commercial patterns, but to select the pattern of correct size and later to make pattern adjustments to fit your figure you have to know your own measurements.

1.2 PREPARATION FOR MEASURING

For taking the measurements, use a good quality measuring tape which is sturdy and will not stretch. The metal end of the tape should be used for vertical measurements and the other end for horizontal and circumference measurements. The measurements should be taken over a smooth fitting foundation garment and never over bulky garments. Before taking measurements, tie a cord or string around the waist. Next, take ¼" wide tape and cast it around your armhole. This will make it easier to measure width of shoulders, armhole depth etc. Stand erect with the arms hanging straight at the sides while measurements are being made by some one else. Take snug measurements rather than tight or loose ones. Hold the

tape parallel to the floor for horizontal measurements, and perpendicular to the floor for vertical measurements. As the measurements are taken, record them in a note book.

1.3 LADIES MEASUREMENTS

The various positions on the body where measurements are to be taken are shown.

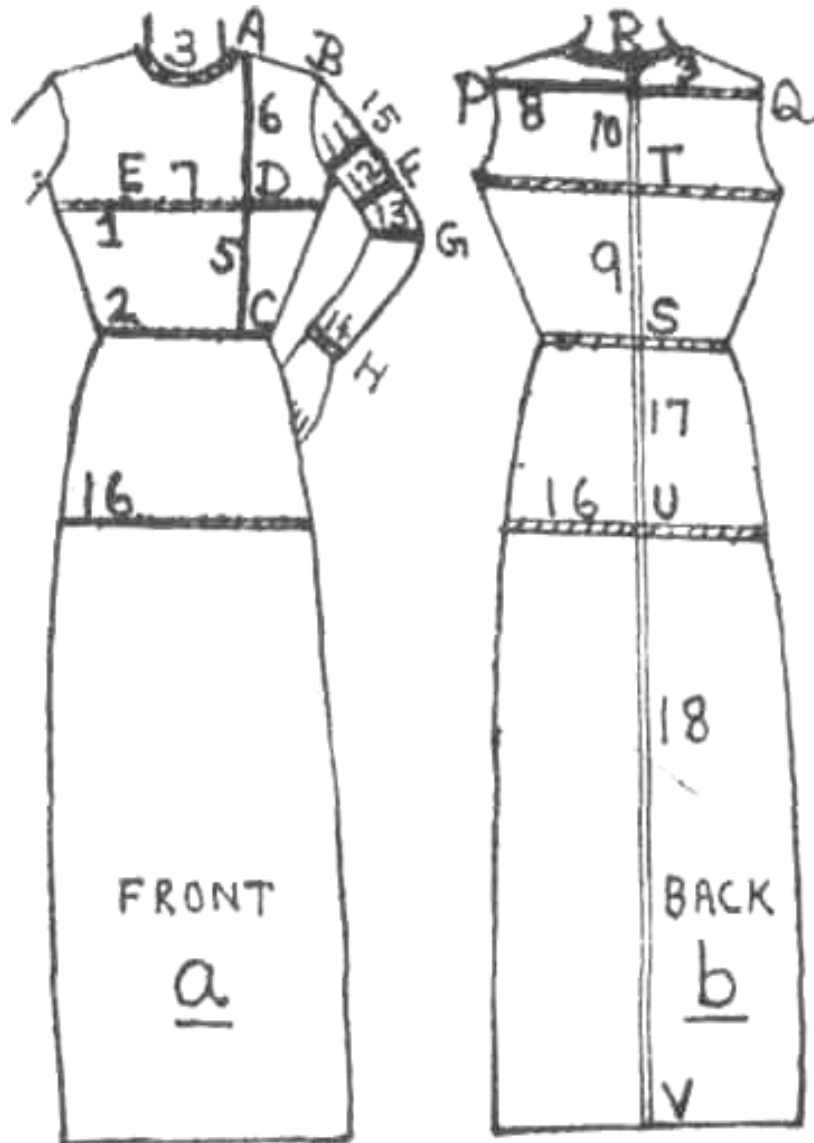


Fig.1.1

Bodice measurements

Bust: Measure around the fullest part of the bust raising the measuring tape slightly to a level just below the shoulder blades at the back.

Waist: Measure snugly around the waist (where you tied the cord) keeping the tape parallel to the floor.

Neck: Measure around the neck, passing the tape just above the collar bone in front and along the base of the neck at the back.

Shoulder: Measure from the neck joint to the arm joint along the middle of the shoulder (A to B in Fig.1.1a).

Front waist length: Measure down from neck at highest point of shoulder to waist line through the fullest part of the bust (A to C in Fig.1.1a).

Shoulder to bust: Measure down from highest point of shoulder to tip of bust (A to D in Fig.1.1a).

Distance between bust points: Measure in the horizontal direction, the distance between the two bust points (D to E in Fig.1.1a).

Back width or across back measurement: Measure across the back from armhole to armhole about 3 inches below base of neck (P to Q in Fig.1.1b).

Back waist length: Measure from the base of neck at the centre back to waist line (R to S in Fig.1.1b).

Armscye depth: Measure from base of neck at centre back to a point directly below it an in level with the bottom of the arm where it joints the body (R to T in Fig.1.1b).

Sleeve measurements

Upper arm circumference: Measure around the fullest part of the arm.

Lower arm: Measure around the arm at desired level corresponding to lower edge of sleeve.

Elbow circumference: Measure around the arm elbow.

Wrist: Measure around the wrist.

Sleeve length: For short sleeve length, measure down from tip of shoulder at top of arm to desired length of sleeve (B to F in Fig.1.1a). For elbow length sleeve measure from top of arm to elbow point (B to G in Fig.1.1a). For full length, bend the elbow slightly and measure down from top of arm to back of wrist passing the tape over the elbow point (B to H in Fig.1.1a).

Skirt measurements

Waist: Same as for bodice.

Hip: Measure around the fullest part or the hip horizontally. (This level will be bout 7 to 9 inches below the waist for an average figure).

Waist to hip: Measure down from waist at centre back to fullest part of the hip (S to U in Fig.1.1b).

Skirt length: Measure down the centre back from waist to desired length of skirt (S to V in Fig.1.1b).

1.4 BOYS AND MEN'S MEASUREMENTS

Many measurements are common for both women's garments and men's garments. In addition to women's measurements fewer measurements are required for mens and boys garments. They are listed below:

Shirt Length

Shirt length should be measured from neck at highest point of shoulder to desired length along the front.

Pant Length

Pant length is measured from waist to ankle along with side of the body.

Cuff Measurement

Cuff measurement is estimated by measuring the wrist loosely and adding ½” overlap extension to it.

1.5 STANDARDIZING BODY MEASUREMENTS**1.5.1 IMPORTANCE AND TECHNIQUES**

Measurement surveys collect measurement data to produce sizing systems. They are very costly. To obtain reliable data, thousands of subjects have to be measured and it is very difficult to obtain public money for the task. The last comprehensive British survey of women's body measurements, publicly available, was published in 1957. Many companies still use this data, but modify it with reference to European surveys, their own sample surveys of their particular product market, leaked information or other available data: e.g. an increase in waist measurement and the height increase in younger women.

Measurement by different types of scanning has been developed. Experimental work is taking place with the Hamamatsu Photonics Bodyline near infrared scanner in the Department of Computer Science, University College, London. Recent surveys have been undertaken at Loughborough University using a shadow scanner (LASS). This method creates a measurable three-dimensional image. A slit of light is passed over a rotating body whilst cameras record the image. Dimensions around and through the body can be recorded. The French system TELMAT has updated its 2D body measurement system to 3D imagery in order to provide more accurate calculations of body measurements.

Conversions of imagery into body measurements appear to have difficulties with complex angular measurements, identifying body landmarks and a recognition of the changing state of the body. Clothing technologists take this into account when taking body measurements manually. A system of manual measurement using an anthropometric stand and special harness has been developed by a researcher at the Manchester Metropolitan University.

Many measurement surveys are confirmed jointly by public research bodies and by companies and they view the resulting data as commercial information which is privately held. The lack of publicly available measurement data has meant that the British Standards BS 5511 and BS 3666 have remained main guides to British size ranges and labeling information. However, the handbook is now available for designers and manufacturers from the Consumer Safety Unit (CSU) of the UK Department of Trade and Industry. The handbook is a design resource produced by the Institute of Occupational Ergonomics at the University of Nottingham. The handbook brings together all available anthropometric and strength data on 266 anthropometric dimensions and 28 strength measurements. Data are presented from a range of countries from Europe, Asia and the USA.

British Standards

Sizing: The British Standards Institution has established a size designation system that indicates (in a simple, direct and meaningful manner) the body size of the woman that a garment is intended to fit. The size designation system is based on body and not garment measurements.

Size Designation: The size designation of each garment should comprise the control dimensions, in centimeters, of the intended wearer of that garment.

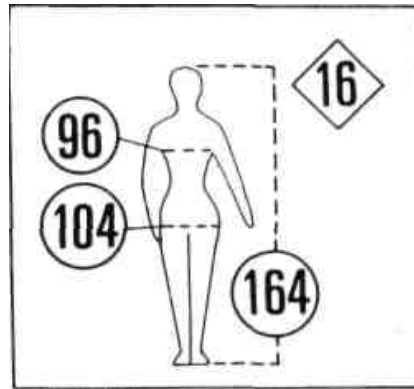
TABLE 1
SIZE CODES AND ASSOCIATED BODY MEASUREMENTS

Size codes	Body measurements			
	Hips		Bust	
	From	To	From	To
	cm	cm	cm	cm
8	83	87	78	82
10	87	91	82	86
12	91	95	86	90
14	95	99	90	94
16	100	104	95	99
18	105	109	100	104
20	no	114	105	109
22	115	119	110	114
24	120	124	115	119
26	125	129	120	124
28	130	134	125	129
30	135	139	130	134
32	140	144	135	139

Where practicable, the pictogram should be used as a means of indicating the size designation. Where it is not practicable to use the pictogram, the control measurements should be given, together with the descriptive words such as bust girth, hip girth, etc. alongside, in the order shown below.

Tables from BS 3666: 1982 Size coding scheme for women's outer wear are reproduced by permission of The British Standards Institution, 2 Park Street, London W1A 2BS.

Example of inclusion of size code number into label



SIZE	16
BUST GIRTH	96
HIP GIRTH	104
HEIGHT	164

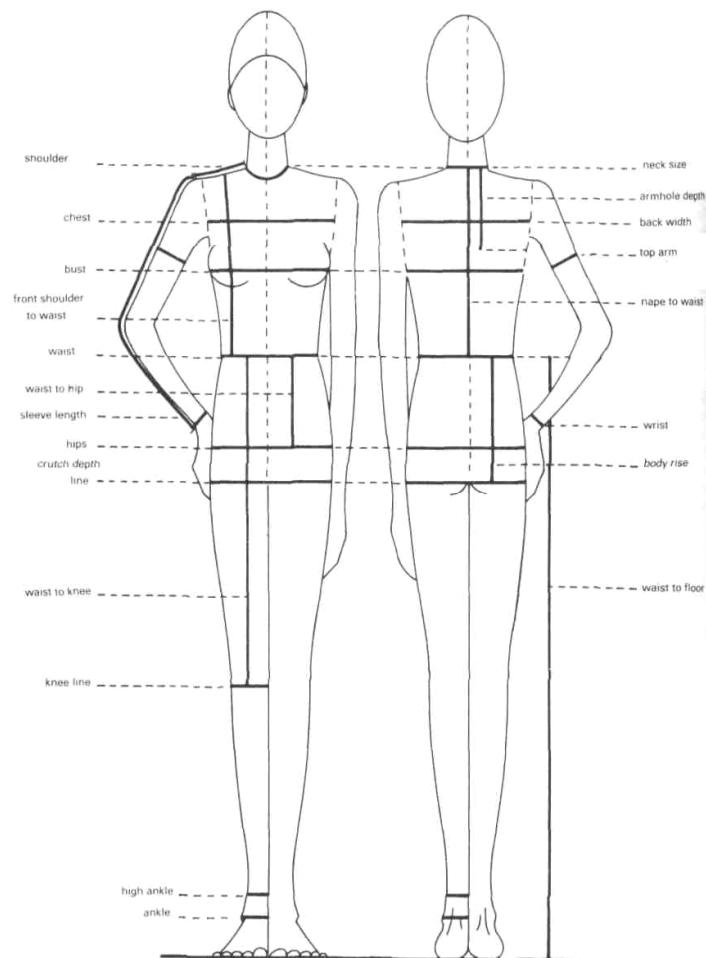


Fig.1.2

The largest percentage of the population falls into medium height range. Although the girth of women varies, the general trend is for weight to increase with height. This feature is reflected in the size charts.

	WOMEN OF MEDIUM HEIGHT 160cm, 170cm (5ft 2½ in – 5ft 6½ in)											
SIZE SYMBOL	8	10	12	14	16	18	20	22	24	26	28	30
BUST	80	84	88	92	97	102	107	112	117	122	127	132
WAIST	60	64	68	72	77	82	87	92	97	102	107	112
HIPS	85	89	93	97	102	107	112	117	122	127	132	137
BACK WIDTH	32.4	33.4	34.4	35.4	36.6	37.8	39	40.2	41.4	42.6	43.8	45
CHEST	30	31.2	32.4	33.6	35	36.5	38	39.5	41	42.5	44	45.5
SHOULDER	11.75	12	12.25	12.5	12.8	13.1	13.4	13.7	14	14.3	14.6	14.9
NECK SIZE	35	36	37	38	39.2	40.4	41.6	42.8	44	45.2	46.4	47.6
DART	5.8	6.4	7	7.6	8.2	8.8	9.4	10	10.6	11.2	11.8	12.4
TOP ARM	26	27.2	28.4	29.6	31	32.8	34.4	36	37.8	39.6	41.4	43.2
WRIST	15	15.5	16	16.5	17	17.5	18	18.5	19	19.5	20	20.5
ANKLE	23	23.5	24	24.5	25.1	25.7	26.3	26.9	27.5	28.1	28.7	29.3
HIGH ANKLE	20	20.5	21	21.5	22.1	22.7	23.3	23.9	24.5	25.1	25.7	26.3
NAPE TO WAIST	39	39.5	40	40.5	41	41.5	42	42.5	43	43.2	43.4	43.6
FRONT SHOULDER TO WAIST	39	39.5	40	40.5	41.3	42.1	42.9	43.7	44.5	45	45.5	46
ARMHOLE DEPTH	20	20.5	21	21.5	22	22.5	23	23.5	24.2	24.9	25.6	26.3
WAIST TO KNEE	57.5	58	58.5	59	59.5	60	60.5	61	61.25	61.5	61.75	62
WAIST TO HIP	20	20.3	20.6	20.9	21.2	21.5	21.8	22.1	22.3	22.5	22.7	22.9
WAIST TO FLOOR	102	103	104	105	106	107	108	109	109.5	110	110.5	111
BODY RISE	26.6	27.3	28	28.7	29.4	30.1	30.8	31.5	32.5	33.5	34.5	35.5
SLEEVE LENGTH	57.2	57.8	58.4	59	59.5	60	60.5	61	61.2	61.4	61.6	61.8
SLEEVE LENGTH (JERSEY)	51.2	51.8	52.4	53	53.5	54	54.5	55	55.2	55.4	55.6	55.8
Extra measurements (garments) CUFF SIZE SHIRTS	21	21	21.5	21.5	22	22.5	23	23.5	24	24.5	25	25.5
CUFF SIZE, TWO-PIECE SLEEVE	13.25	13.5	13.75	14	14.25	14.5	14.75	15	15.25	15.5	15.75	16
TROUSER BOTTOM WIDTH	21	21.5	22	22.5	23	23.5	24	24.5	25.4	26.2	27	27.8
JEANS BOTTOM WIDTH	18.5	18.5	19	19	19.5	20	20.5	21				

	Short Women 152cm-160cm (4ft 11 ½ in 5ft-2 ½ in)	Tall women 170cm-178cm (5ft 6½ in 5ft-9 ½ in)
NAPE TO WAIST	-2cm	+2cm
SCYE DEPTH	-0.8cm	+0.8cm
SLEEVE LENGTH	-2.5cm	+2.5cm
WAIST TO KNEE	-3cm	+3cm
WAIST TO FLOOR	-5cm	+5cm
BODY FISE	-1cm	+1cm

A number of companies are, for commercial reasons, using 5cm intervals between all sizes. This procedure eliminates the size 8 and allows many grading increments to remain the same across the size range. A 5cm interval size chart for use with the popular sizes 10-22 is shown below. Note the size chart just stays within the lower limit of the BSI size range standard for size 10.

WOMEN OF MEDIUM HEIGHT 160cm-170cm (5ft 2 ½in - 5ft 6½ in)							
SIZE	10	12	14	16	18	20	22
BUST	82	87	92	97	102	107	112
WAIST	62	67	72	77	82	87	92
HIPS	87	92	97	102	107	112	117
BACK WIDTH	33	34.2	35.4	36.6	37.8	39	40.2
CHEST	30.5	32	33.5	35	36.5	38	39.5
SHOULDER	11.9	12.2	12.5	12.8	13.1	13.4	13.7
NECK SIZE	35.6	36.8	38	39.2	40.4	41.6	42.8
DART	6.4	7	7.6	8.2	8.8	9.4	10
TOP ARM	26.4	28	29.6	31.2	32.8	34.4	36
WRIST	15.5	16	16.5	17	17.5	18	18.5

ANKLE	23.4	24	24.6	25.2	25.8	26.4	27
HIGH ANKLE	20.4	21	21.6	22.2	22.8	23.4	24
NAPE TO WAIST	39.5	40	40.5	41	41.5	42	42.5
FRONT SHOULDER TO WAIST	39.5	40	40.5	41.3	42.1	42.9	43.7
ARMHOLE DEPTH	20.5	21	21.5	22	22.5	23	23.5
WAIST TO KNEE	58	58.5	59	59.5	60	60.5	61
WAIST TO HIP	20.3	20.6	20.9	21.2	21.5	21.8	22.1
WAIST TO FLOOR	103	104	105	106	107	108	109
BODY RISE	27.3	28	28.7	29.4	30.1	30.8	31.5
SLEEVE LENGTH	57.3	58	58.7	59.4	60.1	60.8	61.5
SLEEVE LENGTH (JERSEY)	51.3	52	52.7	53.4	54.1	54.8	55.2

Standard Body Measurements

The chart is compiled for High Street Fashion garments

Small = approx size 8-10

Medium = size 12

Large = approx size 14-16

X Large = size 18

SIZE SYMBOL BUST	SML S	MED M	LGE L	XLGE XL
BUST	82	88	94	100
WAIST	62	68	74	80
HIP	87	93	99	105
BACK WIDTH	32.8	34.4	36	37.6
CHEST	30.6	32.4	34.2	36
SHOULDER	11.9	12.3	12.6	13
NECK SIZE	35.5	37	38.5	40
DART	6.1	7	7.9	8.8
TOP ARM	26.4	28.4	30.4	32.4
WRIST	15.3	16	16.7	17.4

ANKLE	23.1	24	24.9	25.8
HIGH ANKLE	20.1	21	21.9	22.8
NAPE TO WAIST	39.2	40	40.8	41.6
FRONT SHOULDER TO WAIST	39.2	40	41	42
ARMHOLE DEPTH	20.2	21	21.8	22.6
WAIST TO KNEE	57.7	58.5	59.3	60.1
WAIST TO HIP	20.2	20.6	21	21.4
Extra measurements (garments) CUFF SIZE SHIRTS	21	21.5	22	22.5
CUFF SIZE, TWO PIECE SLEEVE	13.5	13.75	14	14.25
TROUSER BOTTOM WIDTH	21.5	22.	22.5	23
JEANS BOTTOM WIDTH	18.5	19	19.5	20

1.6. LET US SUM UP

In this unit, we

- Learn what is the importance of body measurements and how to take body measurements

1.7. LESSON END ACTIVITIES

- The distance students can have a practical experience among yourself by carrying out trials in taking body measurements

1.8. POINTS FOR DISCUSSION

- Analyze the importance of Body measurements and how to prepare yourself before taking body measurements.
- Establish a standard measurement chart containing measurements for different age groups.

1.9 REFERENCES

- Practical Clothing Construction – Part I and II, Mary Mathews, Cosmic Press, Chennai (1986).
- Metric pattern cutting – Winifred Aldrich, Black Well Science Ltd, III Edition, France (2003).

LESSON – 2: HEAD THEORY

CONTENTS

- 2.0. Aims and Objectives
- 2.1. Head theory
 - 2.1.1. Eight head theory
 - 2.1.2. Relative length measurements in gentlemen/women
 - 2.1.3. Relative width measurements in gentle men and women
- 2.2. Let us sum up
- 2.3. Lesson end activities
- 2.4. Points for discussion
- 2.5. References

1.0 AIMS AND OBJECTIVES

In this unit we have discussed about eight head theory its importance and techniques.

After reading this unit, you should be able to know

- What is head theory with its length and girth measurement in gentlemen/gentlewomen

2.1 HEAD THEORY

2.1.1. EIGHT HEAD THEORY

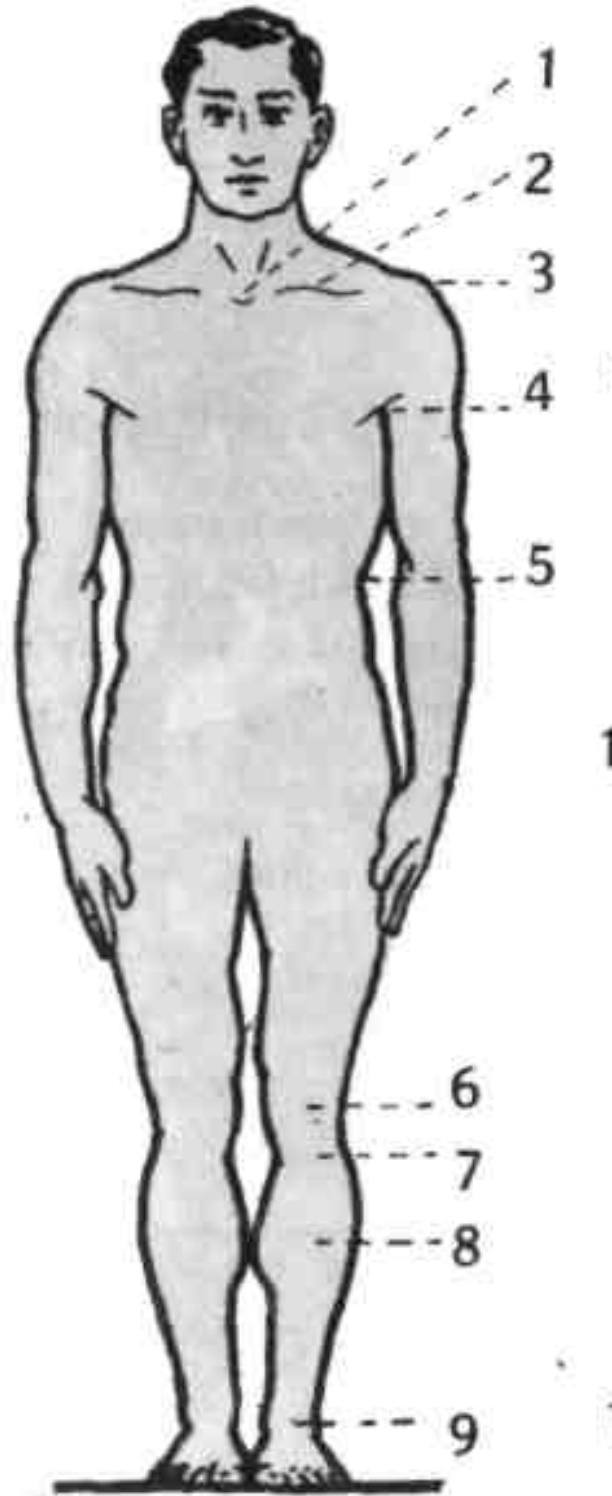
Artists have divided a grown up human body into eight equal parts, which are equal in height to that of the head. So each part is known as the 'head'. All these eight divisions or heads are as follows:

- 1st head = from hair to chin or nape of neck.
- 2nd head = from nape of neck to nipple or bottom of scye.
- 3rd head = from bottom of scye to naval or hollow of waist.
- 4th head = from naval to fork or pubic organs.
- 5th head = from fork to mid thigh or end of fingers, with arm at side.
- 6th head = from mid-thigh to small, below knee.
- 7th head = from small to lower leg, just above the ankle.
- 8th head = from lower leg to ball of foot, standing tip-toe.

Note: Actually the total human height is computed at $7 \frac{1}{2}$ heads, but for easy calculations, the height is taken from hair to the foot, standing tip-toe, thus making eight equal parts.

2.1.2. RELATIVE LENGTH MEASUREMENTS IN GENTLEMEN/WOMEN

Making use of "Eight Heads Theory", the following relative length measures can be obtained, for a grown up proportionate human body.



Relative length measurements in gentlemen/women

Fig.2.1

Nape to the level of armpit	= one-eighth of the height (i.e. 1 head).
Natural waist (i.e. nape to waist)	= one-fourth of the height (i.e.-2 heads).
Fore-arm (i.e. armpit to wrist bone)	= one-fourth of the height (i.e. 2 heads).
Elbow to armpit	= one-eighth of the height (i.e. 1 head).
Inside leg or leg measure	= half the full height (i.e. 4 heads) less 5 to 6 cm (2 to 2 ¼").
Slope of shoulder	= one-sixth of the natural waist length.
Sleeve length (upto wrist) from shoulder	= three-eighth of the height (i.e. 3 heads) less 2 to 4 cm ¾ to 1 ½").
Both the arms extended	= full height of the figure (i.e. 8 heads).
Knee from fork	= half inside leg less 5 cm (2").
Small from knee	= 5 to 6.5 cm (2 to 2 ½").
Calf from small	= about 7.5 to 8.75 cm (3 to 3 ½).
Bodyrise (i.e. waist to fork).	= one-eighth of the height + 5 cm (2").

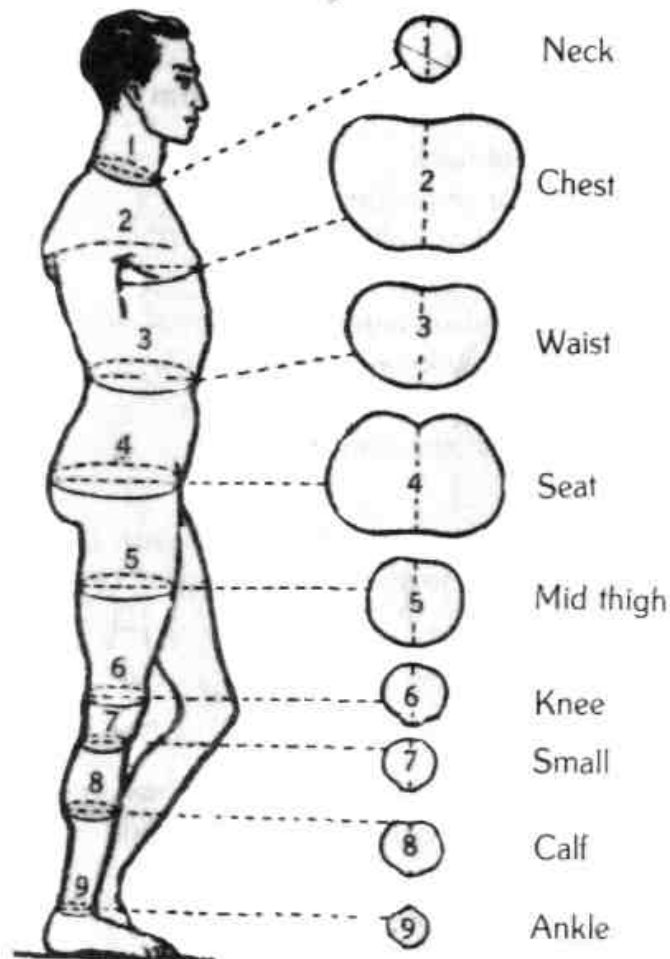
2.1.3. RELATIVE GIRTH MEASUREMENTS IN GENTLEMEN AND WOMEN

Proportions of the girth measures in men are clearly shown in fig.2.2 The girths from top to bottom are as follows:

Out of these girths, the chest measure is very important, as all the other girth measures of a grown up proportionate body are derived from it.

Relative Girth Measures in Men

Neck	= one-third chest + 6.25 to 7.5 cm (2/2 to 3").
Waist	= chest less 10 to 12.5 cm (4 to 5").
Seat	= chest + 2.5 to 5 cm (1 to 2").
Small round	= about one-third seat.
Knee round	= small round + 2.5 to 4 cm (1 to 1 ½").
Calf round	= small round + 2.5 to 4 cm (1 to 1 ½").
Shoulder (half)	= one-fourth chest or less 1.5 cm (½").
Bottom round	= calf round less 2.5 cm (1"), i.e. same as small.
Scye round	= half chest less 0.75 to 1.25 cm (¼" to ½").
Across chest	= one-fourth chest less 2.5 to 4 cm (1 to 1 ½").
Half back	= one-sixth chest + 4 cm (1 ½").



Relative Girth Measures in Men

Fig.2.2

Depth of scye (from neck):

For chest upto 72 cm (28") = one-fourth chest + 1.25 cm (½")

For chest from 72 to 92 cm (28 to 36") = one-fourth chest.

For chest 92 cm (36") and above = one-sixth chest + 7.5 cm (3").

Relative Girth Measures in Ladies (fig.2.3)

The following relative girth measures of matured ladies are useful in cutting garments like blouse, shirt, coat etc.

Neck = one-third bust + 5 to 6.5 cm (2 to 2 ½").

Waist = bust less 12.5 to 18 cm (5 to 7").

Seat = bust + nearly 5 to 10 cm (2 to 4").

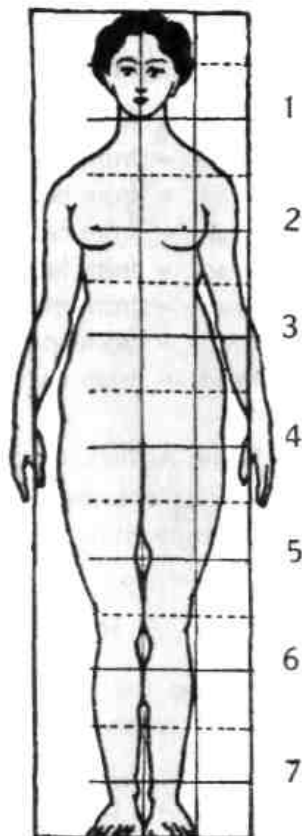
Across chest = one-eighth bust + 5.75 cm (2 ¼").

Halfback = one-sixth bust + 2.5 cm (1").

Shoulder (half) = one-sixth bust + 4 to 5 cm (1 ½ to 2").

Round upper arm = one-fourth bust + 5 to 6.5 cm (2 to 2 ½").

Depth of scye = one-eighth bust + 5 to 6.5 cm (2 to 2 ½").



Relative Girth Measures in Ladies

Fig.2.3

2.2. LET US SUM UP

In this unit, we

- Discussed on head theory and relative length and girth measurements for women/men.

2.3. LESSON END ACTIVITIES

- The distance students can have a practical experience among yourself by sketching eight head theory for men and women.

2.4. POINTS FOR DISCUSSION

- Analyze relative length and girth measurements for gentlemen and women.

2.5. REFERENCES

- Zarapker system of cutting – Zarapkar.K.P., Navneet Publications Ltd.

LESSON – 3: PREPARATION OF FABRIC FOR CUTTING

CONTENTS

- 3.0. Aim and Objective
- 3.1. Preparation of fabric for cutting
 - 3.1.1 Grain and its types
 - 3.1.2. Importance of grain in cutting and construction
- 3.2. Steps in preparing the fabric for cutting
 - 3.2.1. Checking each end of the fabric and straightening it
 - 3.2.2. Checking and straightening the fabric grain
 - 3.2.3. Shrinking fabrics and Pressing
- 3.3. Let us sum up
- 3.4. Lesson end activities
- 3.5. Points for discussion
- 3.6. References

3.0. AIMS AND OBJECTIVES

In this unit we have discussed how to fabric preparation for cutting

After reading this unit, you should be able to know

- How to prepare fabric for cutting

3.1. PREPARATION OF FABRIC FOR CUTTING

The following basic terms should be understood proceeding to prepare the fabric.

Grain (Fig.3.1a) : Grain refers to the direction of yarns in a fabric. Woven fabrics are made up of lengthwise and crosswise or filling yarns interlaced at right angles to each other. These yarns are called the lengthwise and crosswise grains of the fabric. On patterns, lengthwise grain is referred to as straight grain. Bias grain is any direction on a fabric that does not exactly follow a lengthwise or a crosswise yarn. True bias makes a 45° angle with the lengthwise and crosswise yarns.

Lengthwise yarns are usually stronger and heavier and stretch less than crosswise yarns. This property can be used to identify the lengthwise grain on a piece of fabric which has no selvedge. Stretch the fabric along one grain, holding it taut with your two hands held 2"-3" apart; then stretch it similarly along the perpendicular grain. Of the two directions, the one which stretches less is the lengthwise grain.

Selvedge: This is the finished edge of the fabric which runs lengthwise (See Fig.3.1a) Selvedge is woven differently with extra yarns and stronger yarns than the rest of the fabric. In a good quality fabric, the selvedge is very compactly woven and is about half an inch wide. On poor fabrics, selvedge will be narrow and loosely woven.

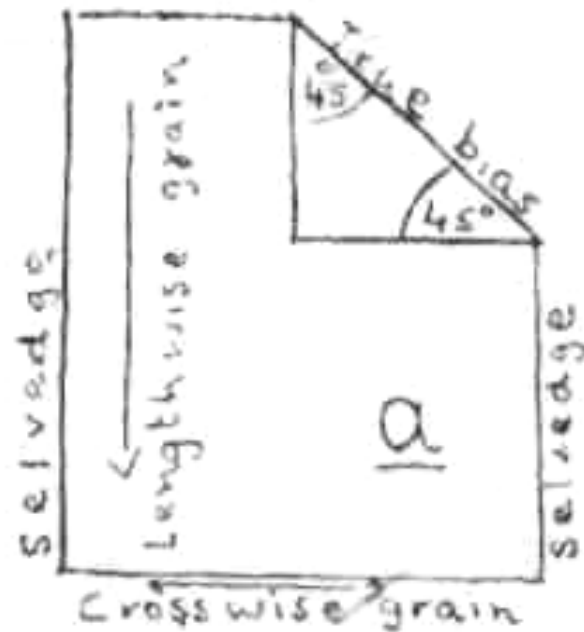


Fig.3.1a

3.1.1 GRAIN AND ITS TYPES

On grain: A fabric in which the crosswise yarns run exactly at right angles to lengthwise yarns and which has right-angled corners is said to be on grain or grain perfect (Fig.3.1b).

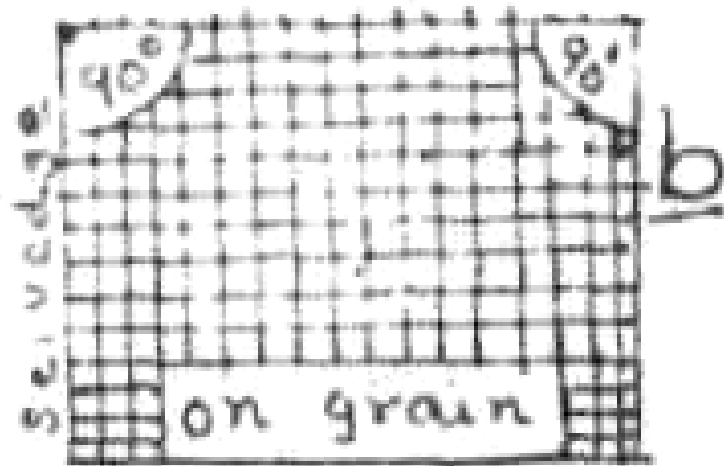


Fig.3.1b

Off grain: A fabric in which the crosswise are not running exactly at right angles to lengthwise yarns is referred to as off grain fabric. This happens because the fabric has been pulled out of shape and pressed in that position during finishing at the factory (Fig.3.1c).

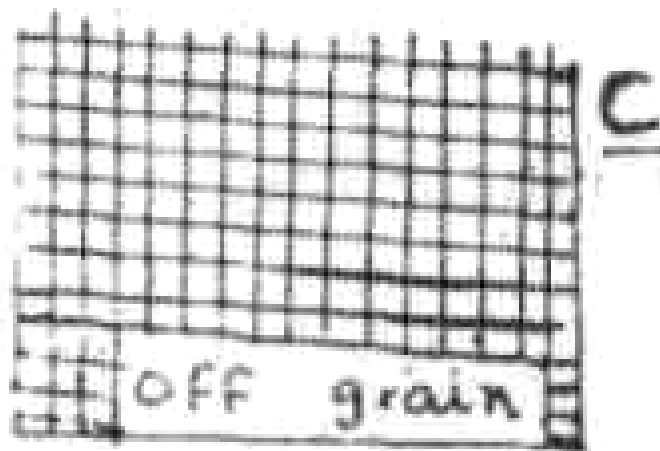


Fig.3.1c

Off grain print: In a print made of lines, checks, etc, if the lines do not run straight along lengthwise or crosswise grain, it is referred to as an off grain print (Fig.3.1d). Fabrics with off grain prints should not be selected for garment construction because with such fabrics it will be almost impossible to make the right and left half of the garment identical in design or to match the design along seams, centre front, centre back etc (See Fig.3.1e).

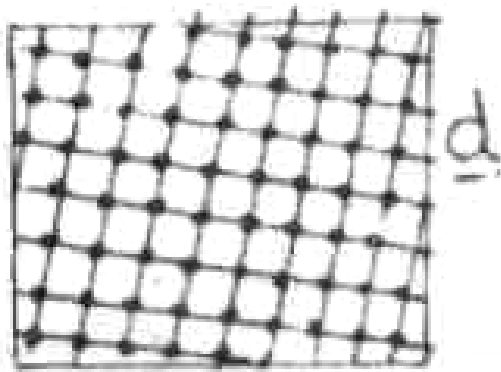


Fig.3.1d

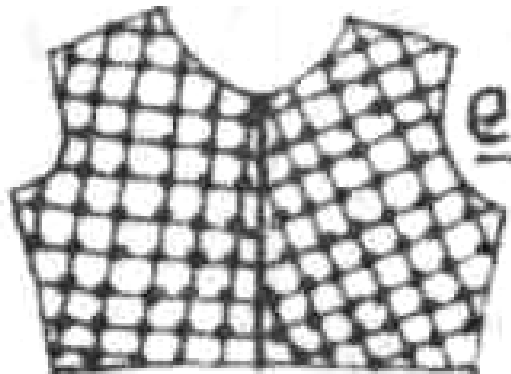


Fig.3.1e

With the grain, Against the grain: Stroke a bias-cut edge of a fabric with your thumb and forefinger. You will find that if the stroking is in one direction the yarns tend to come apart causing the edge to fray, while if you stroke in the opposite direction the yarns close up compactly with the rest of the fabric. The latter direction is said to be with the grain and the former, against the 'grain. (In (Fig.3.1f), the arrow points in the direction with the grain). While working (cutting, stitching, ironing etc.) along a bias edge, one should obviously work with the grain to avoid stretching or raveling. This is especially important for fabrics which ravel easily.



Fig.3.1f

3.1.2 MPORTANCE OF GRAIN IN CUTTING AND CONSTRUCTION

The manner in which a garment is cut in relation to the grain lines of the fabric affects the durability, fit and hang of the garment. Garment should be cut in such a way that the lengthwise grain is parallel to garment length along centre front (along A B in Fig.3.1h), centre back, centre of sleeve (along C D in Fig.3.1g) etc.

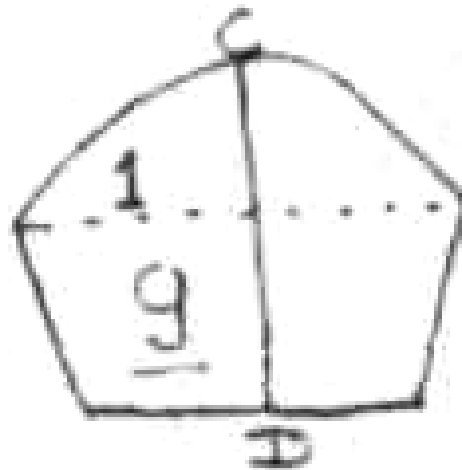


Fig.3.1g

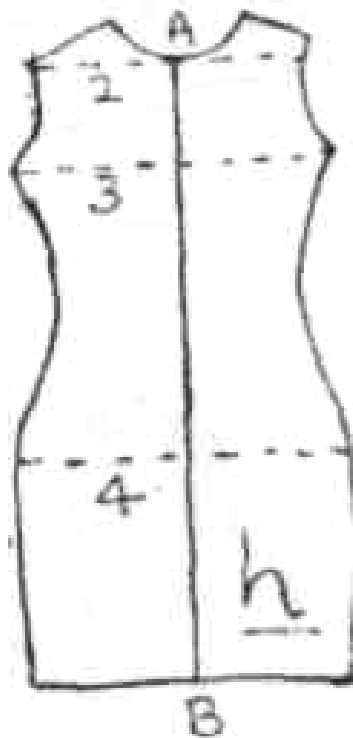


Fig.3.1h

Because of the greater strength of lengthwise yarns, garments cut on lengthwise grain hang better and will be more durable. Ruffles, pleats and gathers will fall in graceful folds only if the folds follow lengthwise yarns. Moreover, the additional stretch of the crosswise grain will be needed across the body for movement.

An exception to the above rule is the case of yokes which are usually cut on crosswise grain (centre front and centre back edge parallel to crosswise grain). Sometimes yokes are cut on bias for design interest. In striped fabrics you may cut the front and back of the garment on true bias to get the chevron effect.

In a well constructed garment, not only should the lengthwise grain run lengthwise on the body but the crosswise grains should be at right angles to the lengthwise grain or parallel to the floor at the base of the neck (line 2 in Fig.3.1h) across the bust (line 3) across the fullest part of the hip (line 4) at the base of the sleeve cap (line 1 in Fig.3.1g) etc. This can not be achieved if you are using an off grain fabric for cutting. The result will be an ill fitting garment which has wrinkles, lacks balance and is uncomfortable to wear. If a dress design should look balanced on the figure, the right half and left half should be identical in design, shape and grain.

In this context special care must be exercised when buying fabrics with printed stripes or checks. If these prints happen to be off grain, as in (Fig.3.1d), you can balance the design on the right and left half of the garment only by disregarding the grain, and this will create problems as mentioned earlier. Even so, this is preferable to making the fabric grain- perfect at the expense of balance in design. These problems do not arise in the case of woven checks and stripes.

As a final point, recall what has been said earlier about cutting and stitching along a bias direction: always work with the grain and not against.

3.2. STEPS IN PREPARING THE FABRIC FOR CUTTING

Preparation of fabric involves the following four steps which are explained in detail further below.

1. Checking each end of the fabric to see whether it is, straight along a crosswise yarn. If it is not, cut it along a crosswise yarn (See Fig.3.2a). This process is called straightening or evening the ends.
2. Checking the fabric to see whether it is grain perfect (i.e., whether the corners form right angles). Straighten the grains, if the fabric is offgrain. (See Fig.3.2b-d).
3. Shrinking the fabric if it has not been pre- shrunk by treatments like Sanforising.
4. Pressing the fabric and removing all creases.

3.2.1. CHECKING EACH END OF THE FABRIC AND STRAIGHTENING IT (FIG.3.2A).

First of all check whether the fabric end is cut or torn. In a torn fabric, the fabric end will be straight along a crosswise yarn and will not need straightening. Torn edge can be recognised by the tiny ends of lengthwise threads visible along this edge. (See edge AB in Fig.3.2a)

If the fabric has cut ends, examine them to see if they are cut along crosswise yarns. If not, straighten them as explained below. (In Fig.3.2a, CD is a cut end that needs straightening).

Methods of straightening fabric ends:

The methods used for straightening the ends of different types of fabrics are the following (a) Loosely woven fabrics or fabrics with prominent crosswise yarns can be cut straight along the visible crosswise yarn. (b) Fabrics that are firmly woven can be torn (with a quick jerk) straight across the fabric after clipping into the selvedge (c) For sheer fabrics and fabrics that fray, clip the selvedge and gently pull one crosswise yarn so that it causes a puckered line. Now cut carefully along this puckered line as far as you can follow it clearly. Now grasp the yarn (or the one next to it) again and repeat the pulling and cutting, across the full width of the fabric. (See Fig.3.2a).

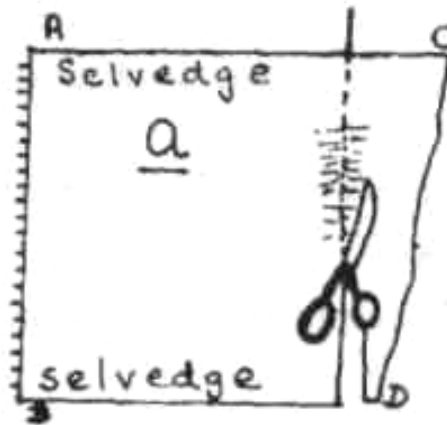


Fig.3.2a

3.2.2. CHECKING AND STRAIGHTENING THE FABRIC GRAIN (FIG.3.2B-D).

After the ends have been straightened, fold the fabric in half lengthwise, matching the selvedges accurately, and place it on a table top as shown with the selvedges exactly in line with the long edge of the table and the crosswise ends falling close to the short edge of the table. If the crosswise ends match evenly and are parallel to the short edge of the table, it is clear that the crosswise ends are at right angles to the selvedges and the fabric is grain perfect (Fig.3.2b).

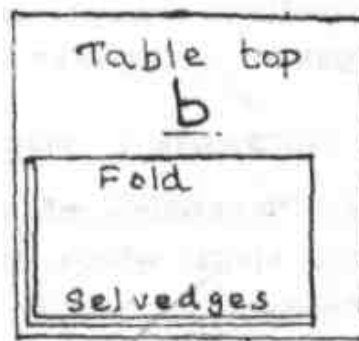


Fig.3.2b

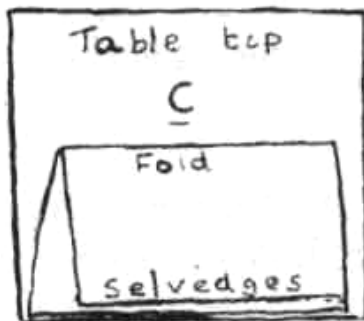


Fig.3.2c



Fig.3.2d

If the crosswise ends do not match evenly and/or are not parallel to the short edge of the table, it shows that the crosswise ends are not at right angles to the selvages. Such a fabric is off grain and needs straightening or restoring of right angled structure (Fig.3.2c).

Methods of straightening fabric grain

Important methods used for straightening fabric grain are the following.

(a) **Stretching method (Fig.3.2d):** The simplest method of making a fabric grain perfect is by stretching it. Open up the fabric, keep it near the corner of a table and pull it on the true bias in the correct direction as shown in the figure. After pulling for some time, fold the fabric and check for grain perfectness as you did before. This process may have to be repeated several times.

(b) **Steam press method:** If the above mentioned method does not work, clip the selvedge at intervals, sprinkle water on the fabric and press with a hot iron in the appropriate direction (instead you may press with a steam iron) till the fabric becomes grain perfect.

(c) **Immersion method:** This is the most effective method for straightening washable fabrics. Fold the fabric lengthwise, tack the selvages together, immerse it in water until it is completely wet, and then squeeze out excess water. Hang up the fabric till it is half dry. Now place it near the corner of a table and carry out the stretching process to make it grain perfect. (Keep paper or cloth underneath to prevent the fabric from getting soiled or stained from the

wooden table-top). After straightening, keep it on a flat surface and dry-When dry, press with an iron and remove the tacking stitches along the edges.

3.2.3. SHRINKING FABRICS AND PRESSING

Cotton fabrics, especially those with the low thread counts which are not Sanforised or pre-shrunk must be shrunk before cutting. Fabrics which have to be shrunk can be made grain perfect at the same time by following the immersion method.

3.3. LET US SUM UP

In this unit, we

- Learnt what is grain, its importance in fabric cutting and steps in preparing fabric for cutting

3.4. LESSON END ACTIVITIES

- The distance students can have a practical experience in a fabric by identifying different types of grains and by preparing fabric for cutting.

3.5. POINTS FOR DISCUSSION

- Analyze the importance of Grain in a fabric

3.6. REFERENCES

- Practical clothing construction – Part I and II, mary mathews, cosmic press, Chennai (1986).

LESSON – 4: TYPES OF PAPER PATTERNS AND METHODS OF PATTERN MAKING

CONTENTS

- 4.0. Aim and Objective
- 4.1. Methods of pattern making
 - 4.1.1. Drafting and draping
 - 4.1.2. Merits and demerits of drafting and draping
- 4.2. Types of paper patterns
 - 4.2.1. Patterns drafted with personal measurements
 - 4.2.2. Commercial patterns
- 4.3. Let us sum up
- 4.4. Lesson end activities
- 4.5. Points for discussion
- 4.6. References

4.0 AIMS AND OBJECTIVES

- In this unit we have discussed the methods of pattern making and types of paper patterns.

After reading this unit you should be able to

- Explain the methods of pattern making
- Discuss about the types of paper patterns

4.1 METHODS OF PATTERN MAKING

A basic pattern can be prepared by one of two methods: (1) by drafting (2) by draping fabric on a model or on the person concerned.

4.1.2 DRAFTING AND DRAPING

Drafting may be defined as a system of drawing patterns on paper with mechanical precision, on the basis of body measurements. This is an effective and economical method which can be learned easily unlike draping which requires a model, a lot of fabric and considerable skill.

4.1.3 MERITS AND DEMERITS OF DRAFTING AND DRAPING

Drafted Patterns

Advantages:

1. A good pattern of the right size which has been adjusted to suit your individual requirements will enable you to obtain a good fit.
2. A pattern prepared on thick paper or card board can be preserved for a long time and can be used over and over again.
3. By manipulating the basic pattern pieces it is possible to produce patterns for complicated and original designs. (For example, the basic sleeve can be adapted for a puff sleeve or bell sleeve etc.)
4. A paper pattern of a particular size can be used to make new patterns of proportionately larger or smaller sizes by following a systematic procedure called "grading".
5. Cutting with the help of a paper pattern is quicker and easier than drafting straight-away on the fabric.
6. Use of a paper pattern will enable you to cut the garment with a minimum amount of fabric because it is possible for you to try out the placement of pattern pieces in different ways till you have found the most economical way to keep them.

Disadvantages:

- a) It is time consuming process as it takes lot of time to draft the pattern.
- b) Unless the techniques and principles of drafting is known it is difficult for the persons to prepare paper pattern.
3. The paper pattern can be rarely used more than once unless copied on a thick sheet.

Draping

Advantages:

1. Varies styles can be tried over the model.
2. Very simple to work once when the techniques is learnt.

Disadvantages:

1. Required skin to drape
2. It requires a model
3. It requires lot of fabric
4. Labourious process
5. Not economical as fabric consumption is more

4.2. TYPES OF PAPER PATTERNS

1. Commercial patterns prepared on the basis of standard measurements.
2. Patterns drafted using personal measurements.

4.2.1 PATTERNS DRAFTED WITH PERSONAL MEASUREMENTS

To draft your own patterns rather than buy commercial patterns. It is most economical, and not too laborious once you have understood the principles of drafting.

As you are drafting the pattern based on your personal measurements, the garment will fit you better especially if your measurements don't have the same proportions as the standard size,

Finally in making your own patterns you have great scope for deriving personal satisfaction from the freedom to create your own designs.

4.2.2 COMMERCIAL PATTERNS

Development of Commercial patterns: Commercial patterns were first made in U.S.A in the 1850's by Ebenezer Butterick who was a tailor. In the beginning they were crude patterns in rough paper, for simple designs only. The first patterns were for men's and boys' clothing. Patterns for women and children were also developed later and became available commercially. You may have seen fashion magazines like Vogue, McCall's Pictorial, Simplicity etc, and their pattern books.

Commercial patterns are usually done on tissue paper. Since tissue paper is not bulky, it allows many pieces of pattern to be packed compactly in an envelope. In commercial patterns seam allowances are included for safety. Patterns of established companies are usually printed and marked clearly with straight grain lines, seam lines, cutting lines, darts, centre lines and all the necessary construction details. Good patterns are carefully labelled with the following information : the pattern size, name of each pattern (back, front, sleeve etc), number of pieces to cut from each pattern piece etc In addition some companies provide instruction sheets explaining the steps involved in using the pattern to cut out the garment, transferring pattern markings, and constructing the garment.

In India there are very few concerns making paper patterns probably because there is not much demand for them. Unlike in foreign countries we have the facility to get our clothes custom tailored at fairly reasonable rates. Housewives and women who know a little bit of tailoring prefer to make their own patterns rather than buying expensive ready made patterns. This may be another reason for the lack of demand for commercial pattern.

4.3. LET US SUM UP

In this unit, we

- Learnt the methods of pattern making and types of paper patterns.

4.4. LESSON END ACTIVITIES

- The distance students can have a practical experience among yourself by preparing drafted paper pattern and commercial paper pattern.

4.5. POINTS FOR DISCUSSION

- Critically analyse the preparation of drafted paper pattern and commercial paper pattern.

4.6. REFERENCES

- Practical clothing construction, Part I and II, Mary Mathews, Cosmic Press, Chennai (1986).

LESSON – 5: PATTERN MAKING - DRAFTING

CONTENTS

- 5.0. Aims and Objectives
- 5.1. Introduction to Pattern Drafting
- 5.2. Principles of pattern drafting and pattern details
- 5.3. Steps in drafting
 - 5.3.1. Basic bodice front and back
 - 5.3.2. Basic sleeve
- 5.4. Let us sum up
- 5.5. Lesson end activities
- 5.6. Points for discussion
- 5.7. References

5.0. AIMS AND OBJECTIVES

- In this unit we have discussed the principles of pattern drafting and steps in drafting.

After reading this unit you should be able to

- Discuss the principles and steps in drafting.

5.1. INTRODUCTION TO PATTERN DRAFTING

The basic blocks can be drafted to fit individual figures by using personal measurements instead of the standard ones. The basic pattern is also referred to as sloper, block, master or foundation pattern. It consists of five pattern pieces – Bodice front, bodice back, skirt front, skirt back and the sleeve. The basic pattern can have only a minimum number of darts and seams and it should fit the body comfortably without being tight or loose. The designer uses a foundation block as a basis for making the pattern for a design. She may introduce style lines, tucks, gathers, pleats or drapes.

5.2. PRINCIPLES OF PATTERN DRAFTING AND PATTERN DETAILS

Drafting can be done on ordinary brown paper which should not however be too thin. To obtain an accurate draft, use a sharp pencil, and a ruler for drawing straight lines. To get the corners at right angles, keep an L scale or set squares ready. Before drafting, it is important to understand the procedures and instructions clearly, and to have practice in drawing a well balanced pattern with smooth curves and straight lines. You must understand the following principles before starting to attempt drafting.

1. Patterns must be made larger than body measurements to allow for freedom of movement, ease of action and comfort in wearing. Recommended ease allowance for various parts of the body are listed below.

Bust 3" to 5" (3" for a tight fitting garment and 5" for loose fitting one); waist $\frac{1}{4}$ " to $\frac{1}{2}$ "; hip 3" to 5"; upper arm 3" to 4"; arm hole depth 1"; bodice length nil; sleeve length nil; skirt length nil.

2. For symmetric designs where the right and left sides are alike, paper pattern for half front and half back only need to be made: For the bodice, start the drafting with the back part. For sleeves, full pattern must be drafted.

3. It is better to draft the primary or basic pattern blocks—plain bodice, plain sleeve, plain skirt without seam allowances. When this is done, be sure to leave seam allowances while laying out the pattern on the material at the time of cutting. If you do not have much experience in cutting, and want to avoid the risk of cutting without seam allowance, you may add seam allowances to your paper pattern itself after completing the draft.

4. The following construction details and information should be recorded and marked clearly.

- a) Name of each piece of pattern (bodice front, bodice back, sleeve etc),
- b) Number of pieces to be cut with each pattern piece. (For example, for a back open dress you have to cut 1 front, 2 backs and 2 sleeves),
- c) If seam allowances are not included in the draft, this should be mentioned. If seam allowances are included, seam lines and cutting lines should be clearly shown,
- d) Length wise or straight grain line should be drawn with a red pencil as shown (<---->) on all pattern pieces. This line indicates that the pattern should be kept on the cloth in such a way that the line is parallel to the length of the cloth or the selvages. It is usually drawn parallel to the centre front and centre back edges of the pattern,
- e) Provide matching notches or balance marks if necessary along seams to show which seams are to be joined together and where,
- f) Centre front and centre back line should be marked. It is advantageous to cut outward notches at centre front and centre back of pattern pieces because at the time of assembling the garment, notches on collars can be matched to notches on the neck line of garment etc.
- g) Fold lines should be clearly shown. Fold lines appear along centre front or centre back edges and sometimes along hems to show where the material is to be folded,
- h) Dart markings, pleat markings etc. should be clearly shown.

5.3. STEPS IN DRAFTING

Sample measurements (7 years old): Chest 24" waist length 10 $\frac{1}{2}$ ", waist 23", back width 11", sleeve length 5".

BASIC BODICE FRONT AND BACK

Bodice pattern (Fig.5.1)

For children, back and front pattern can be drafted within the same rectangle because it is not necessary to make the front larger than the back.

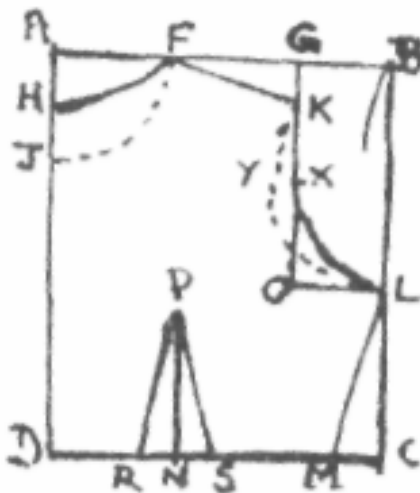


Fig.5.1

Construct rectangle ABCD with the following measurements:

- $AB = \frac{1}{4} (\text{bust} + 5'' \text{ ease allowance}) = \frac{1}{4} \text{ bust} + 1 \frac{1}{4}'' = 7 \frac{1}{4}''$,
- $AD = BC = \text{back waist length} + \frac{1}{2}''$.
- Mark $AG = \frac{1}{2} \text{ back width} = 5 \frac{1}{2}''$,
- $AF = \frac{1}{12} \text{ chest} = 2''$,
- $AH = 1''$,
- $AJ = \frac{1}{12} \text{ chest} + \frac{1}{4}'' = AF + \frac{1}{4}'' = 2 \frac{1}{4}''$ and $GK = 1''$.
- Connect HF with a bold line as shown. This is the back neck line.
- Connect JF with dotted line as shown. This is the front neck line.
- Connect FK with a straight line. This is the shoulder seam.
- Mark $BL = \frac{1}{4} \text{ chest} = 6''$.
- Draw GO parallel to and equal to BL.
- Mark $KX = \frac{1}{3} KO$ and $XY = \frac{1}{2}''$.
- Connect KXL as shown with a bold line. This is the back armscye line.
- Connect KYL as shown with a dotted line. This is the front armscye line.
- Mark $CM = \frac{1}{2}''$. Connect LM. This is the side seam.

For dart, mark $DN = \frac{1}{2} DM - \frac{1}{2}''$ and $NP = CL - 1''$. Mark R and S. $\frac{1}{2}''$ on either side of N and connect RP and SP.

5.3.2. BASIC SLEEVE PATTERN (FIG.5.2)

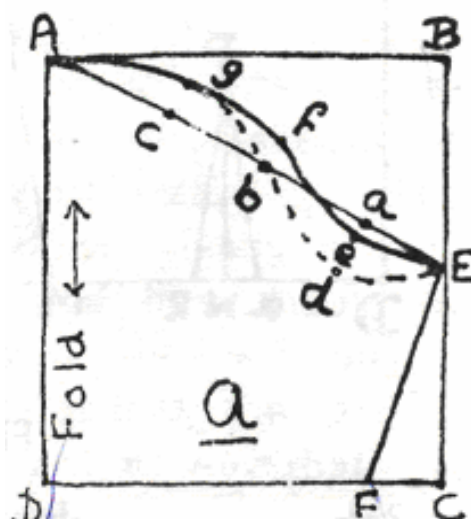


Fig.5.2

The sleeve is drafted in the same manner as an adult's sleeve except for a few differences. Hence a separate diagram is not given for child's sleeve pattern.

In Fig.5.2, AD is on fold and is equal to sleeve length. $AB = \frac{1}{4}$ bust $- \frac{1}{4}$ " (for adults this was $\frac{1}{4}$ bust $- 1 \frac{1}{2}$ "). Mark $BE = \frac{1}{2} AB$ and $DF = \frac{1}{2}$ lower arm $+ \frac{1}{4}$ ". Connect AE. Divide it into 4 equal parts and mark a, b, c. Mark $cg = \frac{1}{2}$ ", $bf = \frac{1}{4}$ ", $ae = \frac{1}{4}$ " and $ad = \frac{1}{2}$ ". Connect AgfeE (back armscye line) and AgbdE (front armscye line). Cut out the sleeve and label it as explained under adult's sleeve.

5.4. LET US SUM UP

In this unit, we

- Discussed on the principles and steps in drafting.

5.5. LESSON END ACTIVITIES

- The distance students can have a practical experience among yourself by carrying out trails in drafting the fabric for different styles of garment.

5.6. POINTS FOR DISCUSSION

- Critically analyse the drafting methods for different styles of garment.

5.7. REFERENCES

- Practical clothing construction, Part I and II, Mary Mathews, Cosmic Press, Chennai (1986).

LESSON – 6: PATTERN MAKING - DRAPING

CONTENTS

- 6.0. Aims and Objectives
- 6.1. Introduction to Draping
- 6.2. Preparation of body form
- 6.3. Steps in draping
 - 6.3.1. Basic bodice front
 - 6.3.2. Basic bodice back
 - 6.3.3. Basic sleeve
- 6.4. Let us sum up
- 6.5. Lesson end activities
- 6.6. Points for discussion
- 6.7. References

6.0 AIMS AND OBJECTIVES

- In this unit we have discussed the methods of pattern making and types of paper patterns. This unit includes the principles and steps in drafting and draping.

After reading this unit you should be able to

- Explain the methods of pattern making
- Discuss about the types of paper patterns
- Discuss the principles and steps in drafting and draping

6.1. INTRODUCTION TO DRAPING

Many designers prefer to use draping methods to create their original designs. A designer can easily see the proportion, fit, balance, and style lines of a design, exactly as it will look on the bodice. Working with actual materials gives a designer greater inspiration and a better indication of the flow and performance of a fabric.

Draping is the manipulation of fabric on a three dimensional form by a designer to obtain perfect fit and harmony between the fabrics and design of the garment and the silhouette of the individual.

Draping or modeling is the moulding of material around a dress stand or human body for the purpose of designing a garment just like a sculptor, modeling allows the fashion designer to work in 3 dimension.

6.2. PREPARATION OF BODY FORM

It is difficult for a person to fit herself and a fitter is not always available, a dress form the exact duplicate of one's figure is almost essential. One that is made on the individual is

more satisfactory and less expensive than the commercially made form. For that reason, the instructions for making a form have been included in this tailoring manual.

Materials needed

- i. Two shirts of thin knit material such as T shirts. Thin muslin cut on the bias and about 5 inches wide, to build up a neck line; or gauze tubing shaped to the figure; or a packaged dress form kit (from a department store) which will contain all necessary material.
- ii. Two rolls of medium weight adhesive paper, one inch wide.
- iii. Eight yards of coloured scotch type, $\frac{1}{4}$ inch wide.
- iv. Stiff, corrugated cardboard, large enough to cut out a base for the largest hip size and a neck size piece.
- v. Other materials: Two sponges, two small basins for water, needle, thread, sharp scissors, surgical scissors if available, pencil, yardstick, rule, tapeline, sharp razor blade with one cutting edge only, small paint brush.

Method of Procedure

Four persons are necessary to construct the form quickly; two to moisten strips, and two to paste strips to person, one working on the front and one on the back. Allow one hour for making the form on the figure and one hour for finishing it after it is removed from the figure.

1. The person should wear a bra and girdle which give desirable style lines. She should so that her hands may be placed on the back of a chair or rest on the edge of a table for support.

To cut the paper, hold the roll with edge extending over a table edge, and cut through the roll with a razor blade.

All strips should be cut before starting to make the form on the person.

Keep it separate on table where each group of strips is cut from the two rolls of tape to prevent confusion and to speed up the operation.

- a. Diagram showing the depth each group of strips is cut from the two rolls. Each group should be labeled as it is cut.
- b. First group of strips is cut $\frac{3}{4}$ inch in from outside of both rolls and are approximately 15 to 12 inches long.

These strips are used from shoulder to waist on first layer, and diagonally from neck down layer, front and back on the second layer.

2. Second group of strips, around 12 to 9 inches, is cut $\frac{3}{4}$ inch from outside of each roll. These strips are used on the first layer from waist to lower hip edge, and on the second layer down from the neck in front and back.
3. Third group of strips, around 9 to 5 inches, cut $\frac{3}{4}$ inch in from outside edge of roll. These strips are used diagonally under the arm on both first and second layers in making the form.
4. Cut around 250 of 3 inch strips for finishing edges of form and for joining the two sections.

- a. Put the shirt, or substitute on the person and sew edges together so that the shirt fits smoothly and firmly on the figure. It should run up onto the neck to form a neckband, extend out over upper arm to form a smooth arm scye, and extend well below the widest hips pull the shirt down smoothly from shoulder, and paste a long strip of moistened tape closely around the normal waistline, overlapping tape ends to prevent slipping, overlapping tape ends to prevent slipping. Paste another strip of tape closely below the widest hip. Paste strips curving under each bust preserve contour.

- b. First layer of strips, 12 to 15 inches. Begin at center front and back, paste moistened strips on the figure from neck and shoulder edges to taped waistline, overlapping strips $\frac{3}{4}$ of the strip width. Let strips curve to body contour as they will, and if too long tear off excess length.

Continue pasting strips to arm scye edge, overlapping strips at top of shoulder. Repeat for second side of front and back. From waist to lower hip edge, paste 9 to 12 inch strips at right angles to waist, joining tape ends to those above the waist. Paste short 5 to 9 inch strips diagonally from under arm to lower hip edge, allowing strips to overlap front and back strips at side front and back. Repeat for second side.

- c. Second layer of tape. Above the waist use 9 to 12 inch strips. Start just below the neck, paste strips diagonally across front, alternating strips from right and left side, having strips overlap at top of shoulder.

As you continue downward, the ends of strips should touch and form the upper arm scye. Continue these crossed strips down the body to the lower hip line edge. Using 12 to 15 inch strips below the waistline. This should form a smooth surface over the entire figure, especially at the waist where joinings, had occurred on the first layer.

- d. Reinforce around arm scye to form a good shape, using 3 to 5 inch strips. Some persons may wish to short sleeve cap. This is formed from 1 to 3 inches beyond arm scye at shoulder tip, using short 3 to 5 inch strips, building a smooth upper arm curve, allowing strips to follow the arm curve when pasting on. (It is difficult to put on and remove garments with an extended sleeve cap).

Finish the neck with one layer of 6 to 9 inch strips around the neck to form a good shape until dress form is removed from person. The neck can be reinforced more sturdily when form is removed.

- e. Measure and mark the form before removing.

Measure from floor up to within 2 or 3 inches below the widest hip and carefully mark for the base of the form.

- f. Mark for removing form from person, down center front and back with ruled line, across front and back at intervals for matching when joining half sections. To remove form from the figure, cut with a one-edged razor blade down center front and back marked lines. Be careful to cut through paper only. Finish cutting through the fabric with surgical scissors or sharp-pointed shears.

Remove the two sections.

Join sections, using 3 inch strips.

Place fronts down on the table with edges and across markings matching both front and back, and pint a tape securely around the waist.

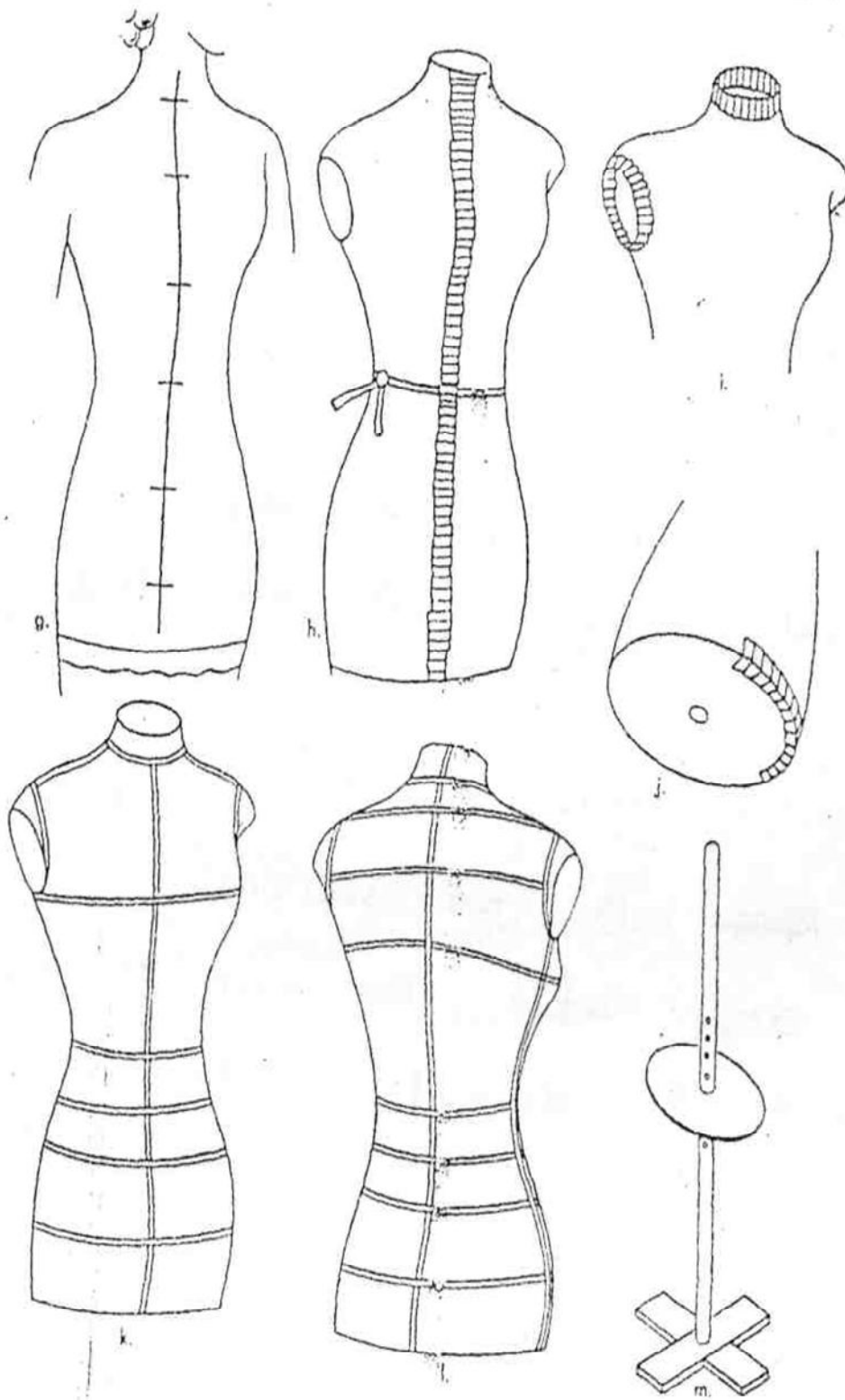


Fig.6.1

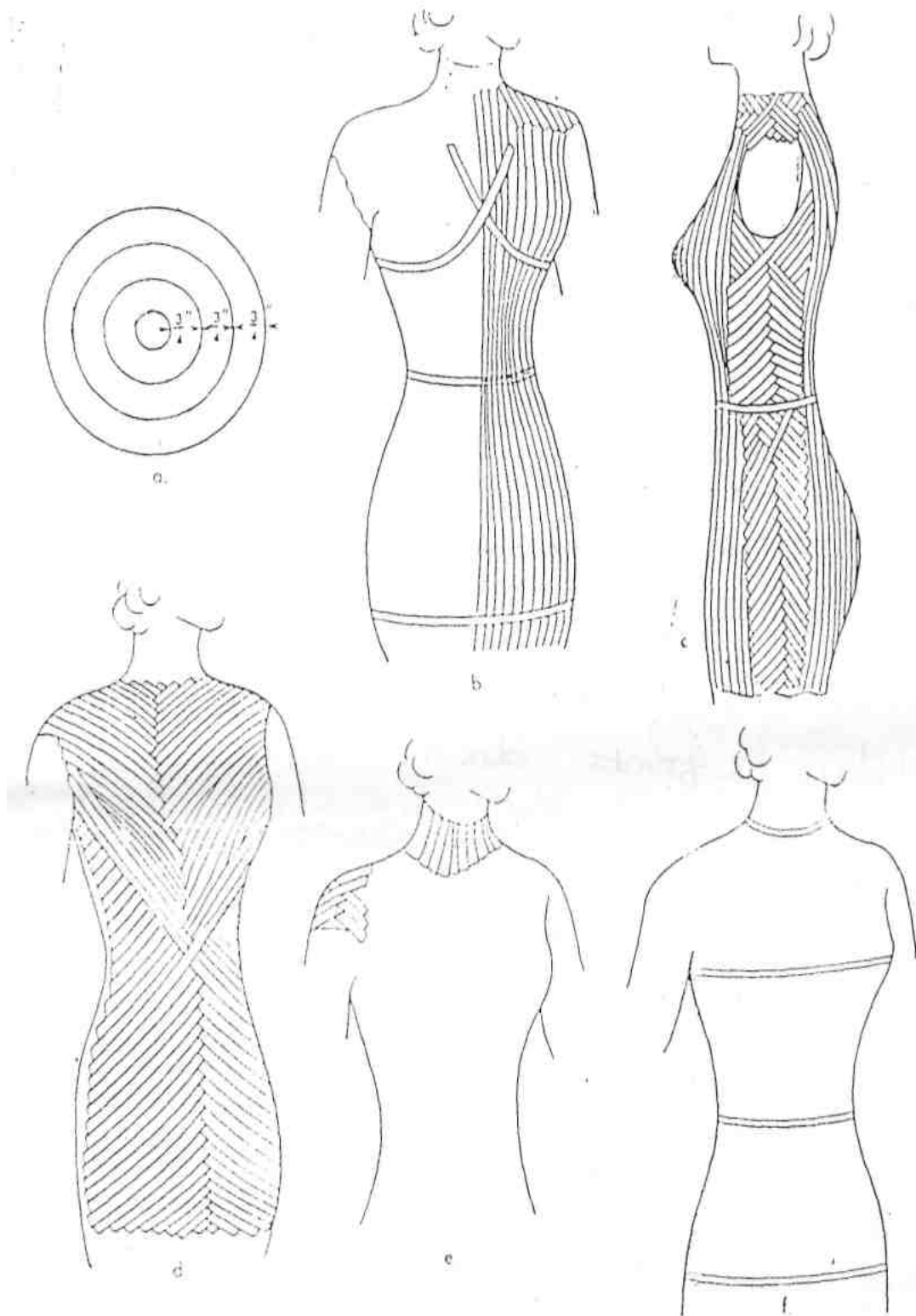


Fig.6.2

6.3 STEPS IN DRAPING

These are some of the points to be considered while draping the fabric on body form.

- a) Analyze the creative elements of design. Identify the design details such as body style, style lines, neck details, collars etc. Determine the draping techniques for that particular design.
- b) Measure and prepare the approximate length and width of the fabric for the design.
- c) Align and Anchor the fabric for the beginning steps, starting with the chosen grain line.
- d) After the fabric has been properly aligned on the dress form, work around the figure.
- e) Trim, clip and cut the excess fabric around the style area.
- f) When the design is completed, remove the fabric from the dress form.
- g) In the finished design together and recheck the fit.

6.3.1 BASIC BODICE FRONT

1. **Pin the apex mark** on the fabric to the apex position on the dress form.

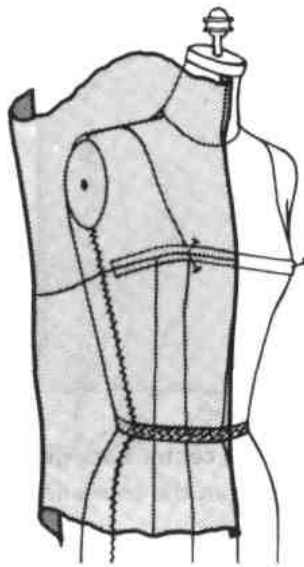


Fig.6.3

2. **Pin the center front grain line fold** of the fabric to the center front position of the dress form.

Anchor pins at center front neck and center front waist. An additional pin may be needed at the bust level tape.

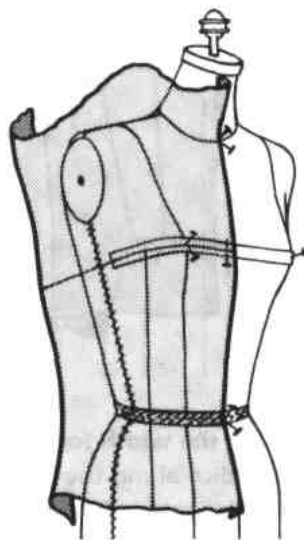


Fig.6.4

3.a. Put a pin on the center of the princess panel position at the waistline on the dress form and use it as a guide for the following steps.

b. Pin the center of the princess panel line of the fabric exactly in the center of the princess panel of the dress form.

c. Anchor pins at the waistline *and in* the cross grain.

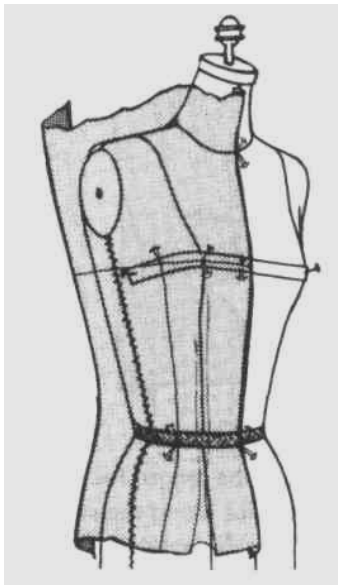


Fig.6.5

4. Pin the front cross grain parallel to the floor (not the bust level tape).

NOTE: The reason for centering the princess panel line is to verify that the cross grain line is perfectly aligned. Check that the lengthwise grain is parallel to the center front and that the cross grain is parallel to the floor.

5. Clip the waistline fabric at the center of the princess panel from the bottom edge up to the waist seam tape.

NOTE: Over clipping the waistline will result in a tight waistline fit and the lack of necessary ease.

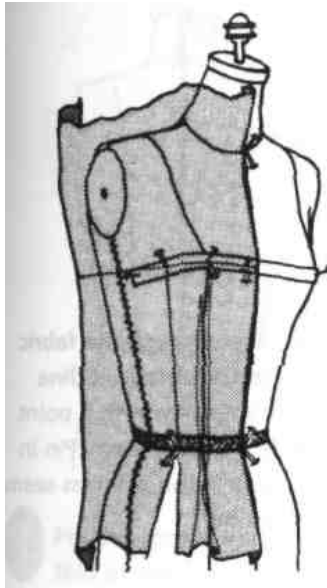


Fig.6.6

6. Pin and drape the front waist dart. The excess fabric that falls between the center of the princess panel and the center front waist position will become the front waist dart. Be careful not to overstretch the waistline or the rib cage area.

a. Crossmark the princess seam at the waistline. Smooth the fabric from center front to the princess seam at the waistline and cross-mark. Crease the fabric at the waistline/princess seam crossmark.

b. Pin the excess fabric on the princess seam. The excess fabric is creased at the princess seam cross-mark and folded toward the center front. Taper the dart to nothing toward the bust apex.

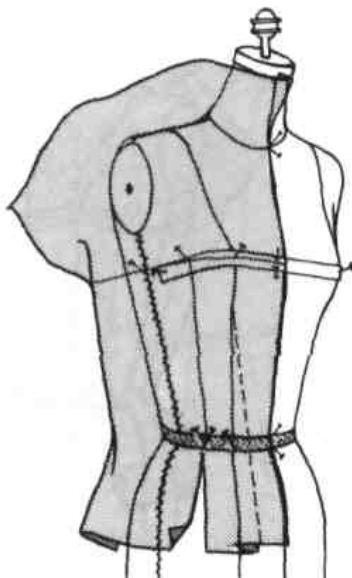


Fig.6.7

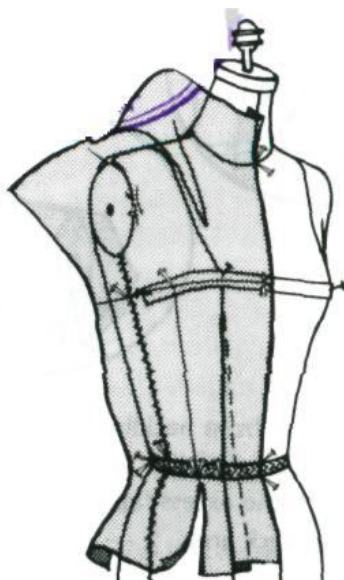


Fig.6.8

7. Smooth and drape the remainder of the waistline. Smooth the fabric across the waist tape until the fabric passes the side seam. Pin at the side seam/waist corner. Leave a 1/8-inch pinch at the waistline. Also, do not mold the rib cage area.

8. Pin and drape the side seam and the beginning of the shoulder.

a. Smooth the excess fabric past the side seam. Be careful not to pull or mold the fabric across the rib cage area.

b. Smooth the fabric up and over the dress form arm plate to the shoulder. Create a V4-inch-1/4-inch pinch at the screw level (middle at ridge) of the armhole. This ensures that

the armhole does not become too tight. Pin in place. Leave all excess fabric in the shoulder area.

NOTE: It is not necessary to make the 1/4-inch-1/4-inch pinch if using a foam form or any amount of arm.

9. Drape the front neckline. Trim and clip the neckline at intervals. Smooth the excess fabric around the neck area.

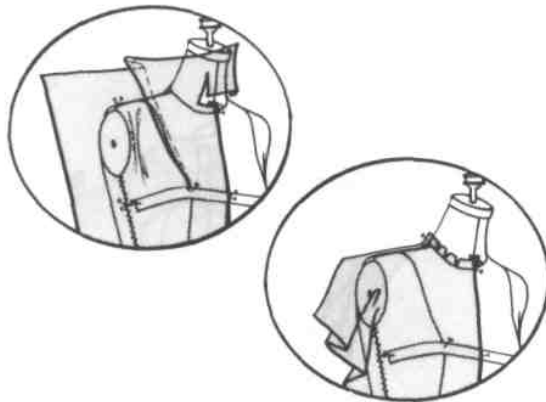


Fig.6.9



Fig.6.10

10. Drape and smooth the fabric over the shoulder/neckline seam of the dress form to a point just past the princess seam. Pin in place. Crossmark the princess seam and the shoulder.

11. Drape the front shoulder dart. The excess fabric that falls between the shoulder/neckline and the shoulder/armhole area will become the amount of excess fabric in the shoulder dart. The larger the bust, the larger the dart; the smaller the bust, the smaller the dart

a. Crease the fabric at the shoulder/princess seam crossmark.

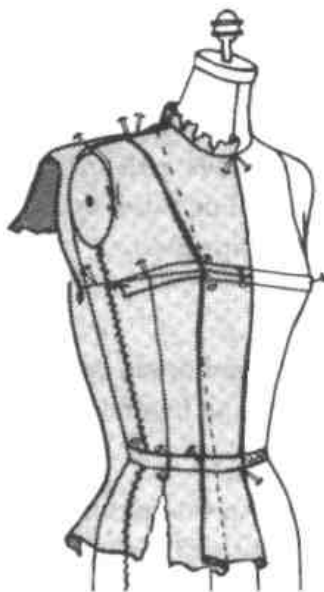


Fig.6.11

b. Pin the excess fabric on the princess seam. The excess fabric is folded at the princess seam cross-mark and folded toward the center front neck. Taper the dart to nothing toward the bust apex.

12. Mark all key areas of the dress form to the fabric.

a. Neckline: Crossmark at center front neck and at neckline/shoulder corner. Lightly mark remainder of neckline.

b. Shoulder seam and shoulder dart: Lightly mark shoulder seam and crossmark shoulder dart and shoulder ridge corner.

Arm plate:

- Top at shoulder seam ridge.
- Middle at screw level.
- Crossmark bottom at side seam.

d. Side seam: Lightly mark.

e. Waistline and waist dart:

Crossmark at center front waist, side seam waist, and both sides of the dart.

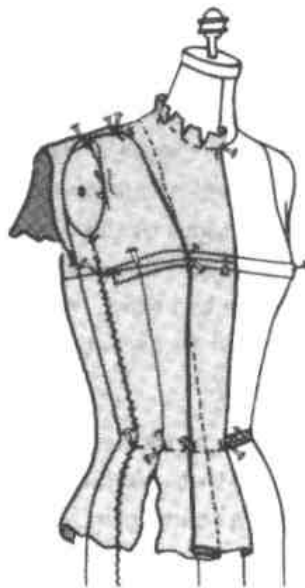


Fig.6.12

6.3.2. BASIC BACK BODICE

1. Pin the center back grain line fold of the fabric to the center back position on the dress form.
2. Align the neckline position mark of the fabric to the center back neck position on the dress form.

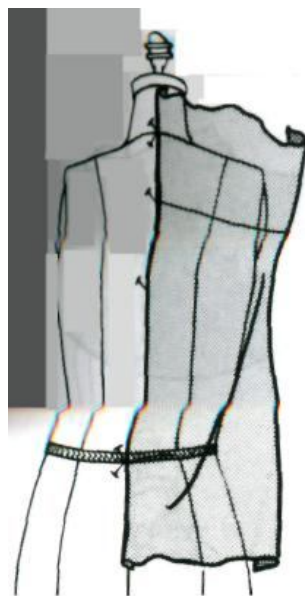


Fig.6.13

3. Pin and drape the back cross-grain line of the fabric to the shoulder blade level on the dress form. Pin the arm plate crossmark 1/4 inch away from the plate (at the armhole ridge). Distribute the excess ease along the shoulder blade level.

NOTE: This line is correctly draped when the drape hangs freely and evenly without any drag or pulled-down look. Also, the lower edge of the drape should hang parallel to the floor.

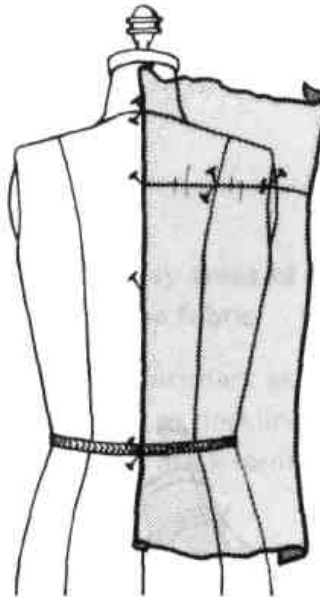


Fig.6.14

4. Pin and drape in the back waistline dart 7 inches long by 1 1/4 inches wide, as follows:

a. Smooth the fabric toward the side seam until the fabric passes the princess seam. Place a cross-mark at the princess/waist seam.

b. Measure and crossmark the waistline 1 1/4 inches toward the side seam from the princess seam/waist crossmark.

c. Measure and crossmark 7 inches up at the middle of the dart, remaining parallel to center back (on grain). Refer to the illustration.

d. Fold the back waistline dart in place. At the waistline, fold the princess seam crossmark to the 1 1/4-inch crossmark. Taper the dart to nothing at the 7-inch mark.

NOTE: The waist dart increases or decreases in width and length as sizes get larger or smaller from a standard size 8 or 10.

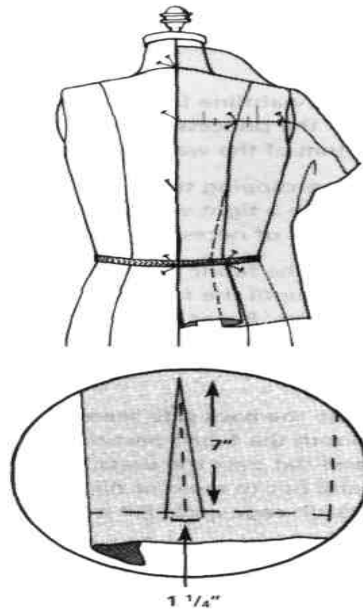


Fig.6.15

5. Clip, smooth, and drape the waistline.

a. Clip the waistline fabric at the center of the princess panel up to the bottom of the waist seam tape.

NOTE: Over clipping the waistline will result in a tight waistline fit and the lack of necessary ease.

b. Smooth the fabric across the waist tape until the fabric passes the side seam. Pin at the side seam/waist corner.

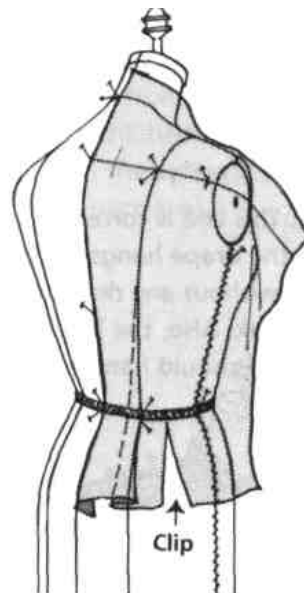


Fig.6.16

6. Drape the back side seam. Smooth the fabric past the side seam and flat over the dress form. Be careful not to mold or distort the back rib cage area. Pin in place.

7. Clip, smooth, and drape the back neckline.

- a. Carefully trim the excess fabric around the neck area, clipping at intervals.
- b. **Smooth the fabric over** the shoulder/neckline area of the dress form and pin in place.

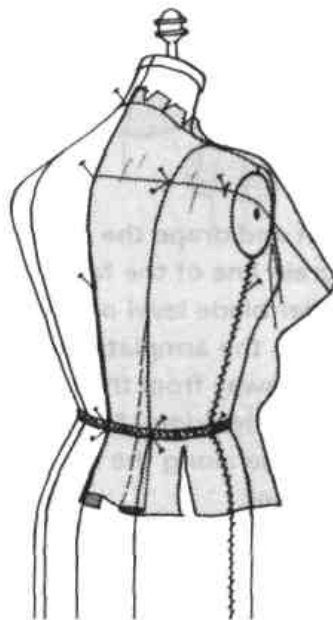


Fig.6.17

8. Drape in the back shoulder dart, 3 inches long by 1/2 inch wide:

a. **Smooth the fabric over the shoulder seam**, starting at the neckline and moving toward the princess seam, and crossmark.

b. **Measure toward the armhole 1/2 inch** from the princess seam at the shoulder (width of back shoulder dart) and crossmark.

c. **Measure down 3 inches** on the princess seam from the shoulder seam and crossmark.

d. **Fold the back shoulder dart in place.** Fold the fabric from the princess seam crossmark to the 1/2-inch crossmark. Taper the dart to nothing at the 3-inch crossmark.

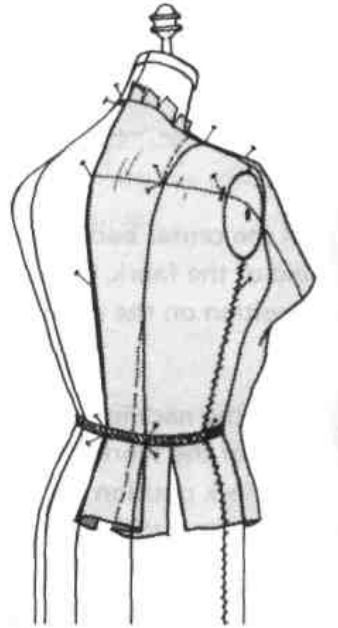


Fig.6.18

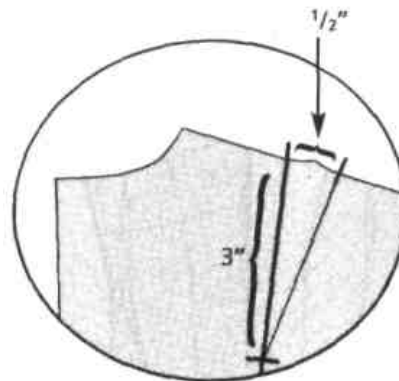


Fig.6.19

9. Mark all key areas of the dress form to the fabric.

a. Neckline: **Crossmark** at center back neck and at neckline/shoulder corner. Lightly mark remainder of neckline.

b. Shoulder seam and shoulderdart:

Lightly mark shoulder seam and crossmark shoulder dart and shoulder ridge corner.

c. Arm plate:

- Mark top at shoulder seam ridge.
- Mark middle at screw level.
- Mark bottom of the plate at the side seam crossmark.

d. Side seam: Lightly mark.

e. Waistline and waist dart:

Crossmark at center back waist, side seam waist, and both sides of the dart.

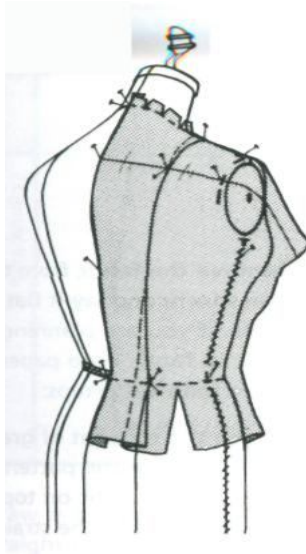


Fig.6.20

The designer may make pattern adjustments but still retain the original character of the sleeve. Fitting a sleeve into a garment is essential when a new sleeve has been drafted. The fitting allows the designer to compare the flat pattern dimensions with the hang movement, proportion, and shape of the actual sleeve.

A properly fitted sleeve will provide the designer with the highest-quality garments. Therefore, fittings must be done carefully and accurately.

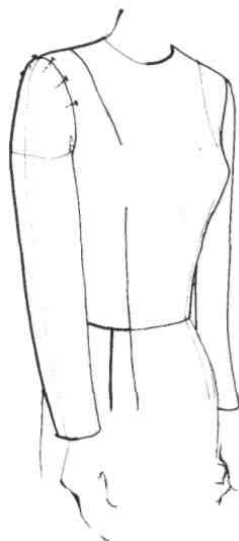


Fig.6.21

6.3.3. BASIC SLEEVE

1. Cut, sew, and crimp the basic sleeve. Cut the basic sleeve out of fabric. Sew the elbow dart and the underarm seam. Crimp the sleeve cap from the front notch to the back notches.

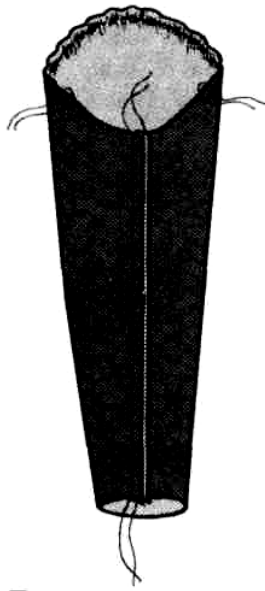


Fig.6.22

2. Pin the underarm seam of the sleeve. Lift the arm to expose the underarm seams and pin the underarm seam of the sleeve to the underarm seam of the bodice armhole. Place the pins parallel to the stitchline, from the front notches down and around to the back notches.

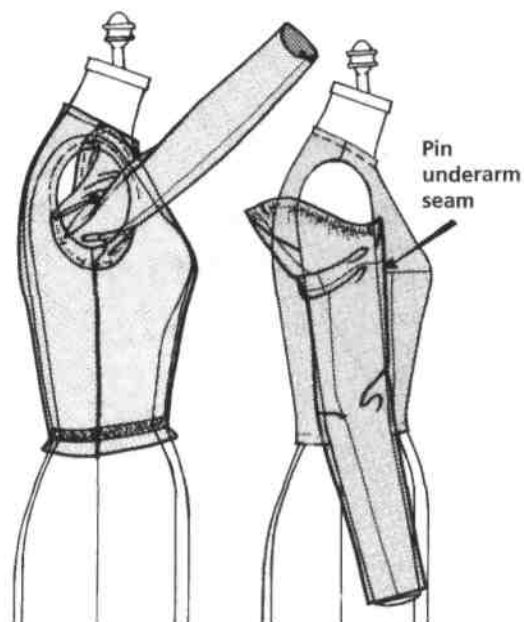


Fig.6.23

3. Pin the sleeve cap to the remaining portion of the armhole, matching the shoulder notch to the shoulder seam of the bodice and all remaining stitchlines.

NOTE: For additional fitting procedures on sleeves.

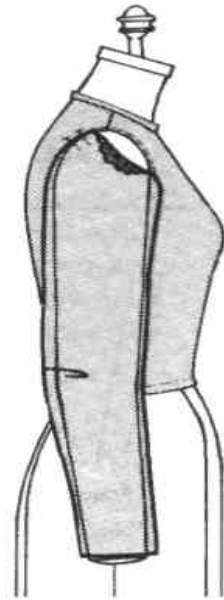


Fig.6.24

6.4. LET US SUM UP

In this unit, we

- Discussed on the preparation of dress form
- Discussed the steps in draping.

6.5. LESSON END ACTIVITIES

- The distance students can have a practical experience among yourself by carrying out trails in draping and the fabric for styles of garment.

6.6. POINTS FOR DISCUSSION

- Critically analyse the draping skill adopted for different styles of garment
- Critically analyse the drafting methods for different styles of garment.

6.7. REFERENCES

- The art of Fashion Draping, Connie Amaden – Crawford, Fairchild Publishers, III Edition, New Delhi (2005).

LESSON – 7: STYLES CREATED USING DART MANIPULATION

CONTENTS

- 7.0. Aim and Objective
- 7.1. Introduction
- 7.2. Styles created by shifting blouse darts
- 7.3. Adding fullness at the top and bottom edges of the bodice
- 7.4. Converting darts to seams
- 7.5. Incorporating darts into seams forming the yoke
- 7.6. Converting darts to a partial yoke
- 7.7. Let us sum up
- 7.8. Lesson end activities
- 7.9. Points for discussion
- 7.10. References

7.0 AIMS AND OBJECTIVES

- In this unit we have discussed the styles created using dart manipulation.

After reading this unit you should be able to

- Create styles using dart manipulation in a garment

7.1. INTRODUCTION

While designing and making patterns for ladies garments it is important to know the principles of dart manipulation. This pattern has two basic darts pointing to the bust line, one from the waistline and the other from the side seam. By pattern manipulation, it is possible to shift the darts into other parts of the bodice without changing the fit of the garment, but creating interesting effects. It is also possible to add extra fullness in the form of gathers, pleats etc. by the slash and spread method.

7.2. STYLES CREATED BY SHIFTING BLOUSE DARTS

Style 1 (Fig.7.1a-a₂):

In this style (Fig.7.1a), the side seam dart has been shifted to the shoulder area by the slash method as follows :



Fig.7.1a

Trace the basic pattern with the darts. Mark the bust point P and extend the side seam dart to the bust point as shown (Fig.7.1a₁).

Fig.7.1a₁

Now draw line CP where the new dart is to be located. Slash along this line to the bust point. Now close the side seam dart and pin. You will find that an open space in the shape of a dart has been formed in the shoulder area (Fig.7.1a₂).

Fig.7.1a₂

Keep this pattern on another paper and draw the final pattern terminating this shoulder dart 2" away from the bust point.

Style 2 (Fig.7.1b-b₂):

In the style shown in (Fig.7.1b) the side seam dart and waistline dart have been shifted to the centre front edge as explained below:

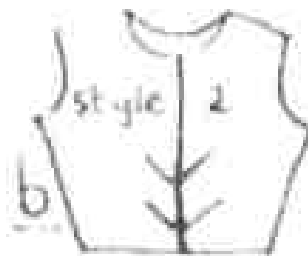


Fig.7.1b

Trace the basic pattern and extend the waistline dart and the side seam dart till the bust point P (Fig.7.1b₁).

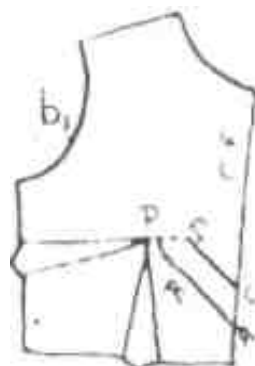


Fig.7.1b₁

Draw lines AB and CD where the new darts are to be located. Connect BP and DP as shown and slash the pattern along these lines. Close the waistline dart and side seam dart and pin as shown in (Fig.7.1b₂) (It will be easier to close the darts if one side of each dart is slashed).

Fig.7.1b₂

Now you will find that two open spaces have been formed at the centre front edge of the pattern. Keep this pattern on another paper and trace the new pattern shortening the darts by 1½" to 2".

Style 3:

Darts shifted to the neckline and converted to gathers (Fig.7.1c-c₂): the waistline and side seam dart to the neckline area where the gathers are desired using the method described under style 1 and style 2 The finish pattern is shown in (Fig.7.1c).



Fig.7.1c

Make a smooth cut at the wide end of the dart and mark notches indicate the beginning and ending of gathers. If you require more gathers near the neckline than 1 dart equivalent, additional fullness must be introduced as follows: Slash the pattern shown in (Fig.7.1c₁) along the dotted lines drawn from the neckline to the waistline and armhole line and spread up the pattern at neckline as shown in (Fig.7.1c₂) Trace this pattern on to a paper.

Fig.7.1c₁Fig.7.1c₂

7.3. ADDING FULLNESS AT THE TOP AND BOTTOM EDGES OF THE BODICE

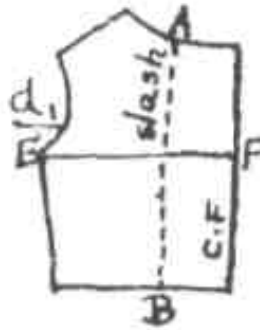
Style 4 (Fig.7.1d-d₂):

In this style (See Fig.7.1d) gathers have been introduced at the neckline waistline as follows

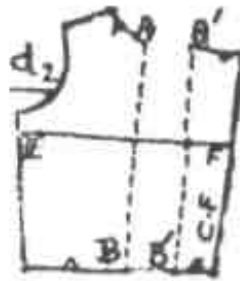


Fig.7.1d

Slash the pattern all the way from the neckline to the waistline (from A to B Fig.7.1d₁) after drawing the horizontal grain line E right angles to the centre front edge of the pattern.

Fig.7.1d₁

Next, take a large sheet of paper and mark a horizontal grain line on it. Keep the two halves of pattern on the new sheet of paper leaving a gap of to 6" depending on the amount of gathers desired) and matching the horizontal grain lines (Fig.7.1d₂).

Fig.7.1d₂

Redraw to get the final pattern. Mark notched indicate the beginning and ending of gathering.

7.4. CONVERTING DARTS TO SEAMS

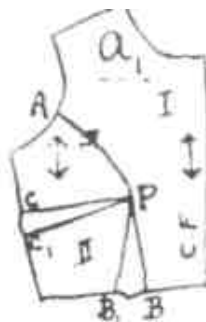
Style 5 (Fig.7.2a-a₂):

This style (Fig.7.2a) has decorative seams from the armhole to the line, dividing the front bodice into three gore panels. The seams can be made more conspicuous by insertion of lace, ruffles or bias binding.

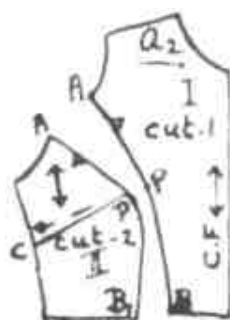


Fig.7.2a

To n the pattern, make a copy of the bodice pattern extend the basic darts to the bust point P. BPB₁ is the extended waistline dart. Extend line BP shown to meet armscye line at point A in the desired position. The curved line APB is the decorative seam line. (Fig.7.2a₁).

Fig.7.2a₁

Label the centre panel as section and side panel as Section II. Mark matching notches and grain lines and cut the pattern apart along line APB. Cut off the dart area of the waistline dart and close the side seam dart. (Fig.7.2a₂) shows the final pattern.

Fig.7.2a₂

Styles 6 to 9 (Fig.7.2b-e):

In all these styles the darts have been converted to seams using the principle explained above. If you are making the pattern for a child's dress, the basic pattern will have only a waistline dart and only this dart has to be cut away or folded in. If there is no dart in the bodice, you just have to draw the style line and cut the pattern apart.



Fig.7.2b



Fig.7.2c



Fig.7.2d



Fig.7.2e

7.5. INCORPORATING DARTS INTO SEAMS FORMING THE YOKE

Style 10 (Fig.7.3a-a₂):

In this style (Fig.7.3a), the darts have been incorporated into the seam forming the yoke.

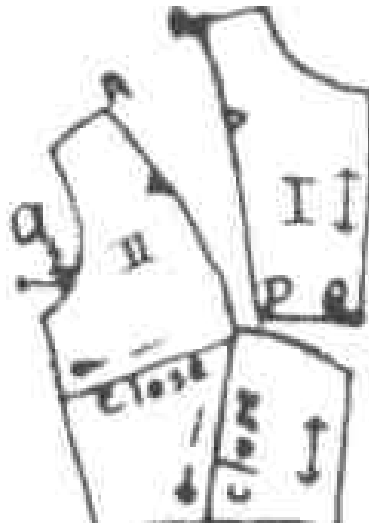


Fig.7.3a

To get the best results points P and P on the yoke should be located at the bust points. To make the pattern, trace the bodice pattern and extend the basic darts till the bust point P (Fig.7.3a₁).

Fig.7.3a₁

Draw the yoke line APQ as explained below. Mark point A at about the midpoint of the shoulder line. Connect A to the bust point P and draw PQ perpendicular to the centre front edge of the pattern. Mark matching notches and grain line. Label the yoke as section and the rest of the blouse as section II. Now cut along APQ and separate the two sections. Close the darts in section II as shown in Fig. Style 11 (Fig.7.3a₂):

Fig.7.3a₂

Style 11 (Fig.7.3b-b₂):

In this style the dart has been converted to gathers in the lower section of the bodice.



Fig.7.3b

To make the pattern, trace the basic bodice pattern, draw the yoke line ABC and button extension as shown (Fig.7.3b₁).

Fig.7.3b₁

Draw dotted lines PQ and RS to points of darts as illustrated. Mark matching notches and grain lines and cut out and separate the yoke from the bodice. (Fig.7.3b₂).

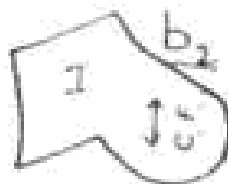


Fig.7.3b₂

Slash along the dotted lines in section II and fold the original darts. Now the pattern will open up as in (Fig.7.3b₃) Place over fresh paper and redraw to get the final pattern.



Fig.7.3b₃

7.6. CONVERTING DARTS TO A PARTIAL YOKE

Style 12 (Fig.7.3c-c₅):

The design shown in (Fig.7.3c) serves much the same purpose as a yoke, but is somewhat similar to a dart in its construction. As the dart seam line does not extend across the entire garment, it is sometimes referred to as a partial yoke.

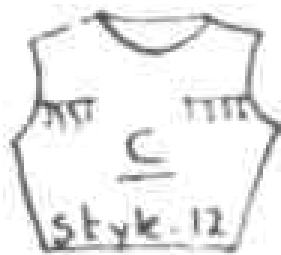


Fig.7.3c

To make the pattern for this style, first of all shift the waistline and side seam darts to the shoulder line (Fig.7.3c₁).

Fig.7.3c₁

Fold the dart and pin it, and draw the design line CD as shown in (Fig.7.3c₂).

Fig.7.3c₂

Draw DE perpendicular to the waistline and cut the pattern along CDE stopping the cutting about 1/8" above the point E. Allow the dart to open up in the lower section of the pattern and spread the pattern as shown (Fig.7.3c₃).

Fig.7.3c₃

Keep the dart in the upper area closed. Keep this pattern on another paper and trace the outline. Allowances must be left on the fabric at the time of cutting as shown by dotted lines, in (Fig.7.3c₄).

LESSON – 8: GARMENT FITTING

CONTENTS

- 8.0. Aim and Objective
- 8.1. Fittings – Introduction
- 8.2. Standards of a good fit
- 8.3. Steps in preparing a blouse for fitting
- 8.4. Checking the fit of a blouse
- 8.5. Solving fitting problems in a blouse
- 8.6. Fitting techniques
- 8.7. Specific fitting problems in a blouse and their remedies
- 8.8. Let us sum up
- 8.9. Lesson end activities
- 8.10. Points for discussion
- 8.11. References

8.0. AIMS AND OBJECTIVES

- In this unit we have discussed about the fitting standard with techniques.

After reading this unit you should be able to

- Check the fit of a garment
- Identify the fitting problems and remedies for the same.

8.1. FITTINGS – INTRODUCTION

The success of your garment depends a great deal on its fit. A well fitting garment has optimum amount of ease (neither too tight nor too loose) and its seam lines follow the general silhouette of the body. It hangs or sets in a well balanced manner without wrinkles, sagging or poking out.

8.2. STANDARDS OF A GOOD FIT

The factors which determine whether a garment has good fit or not are ease, line, grain, set and balance. These factors are referred to as "Standards for a good fit". They are interrelated. For example, if a garment has excess ease or too little ease, the grain lines go out of position, wrinkles appear and the garment may lack balance?

Ease: Ease is the difference between the actual body measurement and the garment measurement at any given point. This amount varies with fashion, type of garment and personal taste. A garment constructed with optimum amount of ease will be of the right size. Pulling or drawing across the bust, shoulder blades, hipline etc. are evidences of insufficient ease. Excess ease causes folds across the loose area giving a baggy appearance to the garment.

Line: Lines to look for in fitting are the basic silhouette seams, circumference seams and design lines. The shoulder seam should be straight across top of shoulder. The side seam

should be straight and must be half way between back and front. The circumference lines include neckline, armhole, waistline and hemline. They should form smooth curves following the natural body curves. The armhole should be oval shaped and should not curve too far into the bodice nor should it extend too far away from the natural joint. The neckline should fit well without pulling or gaping. Waistline and hemline should be parallel to the floor.

Design lines such as pleats, darts, gores, and yokes within the garment should be graceful and smooth.

Grain: When a garment is worn, the fabric grain lines must fall correctly in the proper places on your figure. The lengthwise grain should be perpendicular to the floor at the centre front and centre back of the garment. In the sleeve the lengthwise yarns should hang vertically from shoulder line to centre of sleeve hem. The crosswise yarns should be parallel to the floor across bust, waist, and upper arm of sleeve. In Fig. 8.1.a, b, c. the solid lines are lengthwise grain lines (KL centre front line, PN centre back line and ST centre sleeve line) and the dotted lines are crosswise grain lines (AB and CO across bust lines and EF across upper arm line).

Set: A garment is said to have a good smooth set, if it has no undesirable wrinkles. Wrinkles are slanting triangles caused by the garment being strained over some curve or bulge of the body. The wrinkles pointing towards the shoulder blade in Fig.8.2 is caused by protruding shoulders; to remove them you must provide extra length and width for the garment in this area. If a garment is tight around its circumference, crosswise wrinkles occur above or below the tight area.

Balance: For a good fit, the garment should look balanced from left to right and front to back. A skirt should extend the same distance from the centre to the right and left sides. If the shoulder seam stands away from the shoulder at neck point and fits tightly at armhole point, the garment looks out of balance.

8.3. STEPS IN PREPARING A BLOUSE FOR FITTING

1. To make fitting easier, mark the important grain lines on blouse front, back and sleeve (centre front line, across bust line, centre sleeve line, across upper arm line etc.) by pencil or tacking stitches (See Fig.8.1.a,b,c).

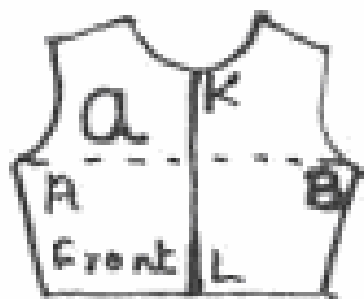


Fig.8.1a

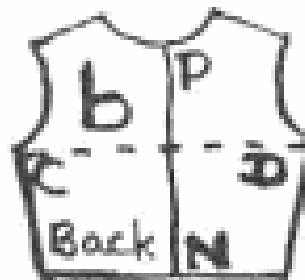


Fig.8.1b



Fig.8.1c

2. Make sure that bias edges and curved edges (especially neckline) are stay stitched before the garment is assembled for fitting.

3. Assemble the garment using small basting (tacking) stitches or machine basting in contrasting coloured thread in the following order,

(a) Blouse front darts (Fig.8.1d).



Fig.8.1d

(b) Blouse back darts (Fig.8.1e)



Fig.8.1e

(c) Shoulder seam and side seams as shown in Fig.8.1f. (While tacking these seams front and back should be kept right sides facing and wrong sides out)

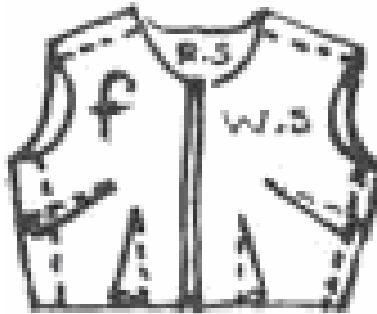


Fig.8.1f

(d) Sleeve hem and side seams of sleeve (Fig.8.1g).



Fig.8.1g

Sleeve should be tacked to the armhole only after checking the fit of the blouse and sleeve separately and making the necessary adjustments.

8.4. CHECKING THE FIT OF A BLOUSE

1. Put on the garment right side out over a good fitting brassiere. If there is a centre opening pin it closed, matching the centre lines on overlap and under lap. (Use several pins). Adjust the blouse so that the centre lines coincide with the centre of your figure.

2. Stand in front of a mirror and study the overall appearance of the blouse. Remember that the armhole, neckline and lower edge of blouse have an extended seam allowance (i.e., the edge of the fabric is not the seam line).

3. Determine the fit of the blouse by checking the following points. (Though it is possible to do this by yourself, it would be better if you have some one experienced to assist you in fitting).

- a) Whether there are any changes needed in length of the bodice, sleeve and shoulder seam.
- b) Whether it has the right amount of ease across bust upper arm, back etc.
- c) Whether the seam lines (shoulder, armscye, side seam, waist line, and neckline) follow the general silhouette of the body.

- d) Whether the grain lines are falling correctly in the proper places on your figure.
- e) Whether there are any wrinkles.
- f) Whether the darts are of optimum width and point towards the bust point ending $\frac{3}{4}$ " to 1" away from the bust point.

8.5. SOLVING FITTING PROBLEMS IN A BLOUSE

Basic Principles:

(1) If there is too little or too much of *ease*, let out the seam or dart near the tight area and deepen (i.e., take in) near the too loose area. Apparent tightness in one area may also be rectified sometimes by deepening the part of the seam where the garment is relatively loose. For example, if the blouse seems tight near the arm joint of shoulder line, taking a deeper seam at neck point of shoulder line may correct the problem.

(2) To get rid of diagonal *wrinkles* provide greater length and/or width near the pointed end of the wrinkle. Sometimes the problem is solved by decreasing the length of the garment at the opposite end. For example, if there are wrinkles pointing towards the shoulder near the arm joint, you may either let cut the shoulder seam and retack reducing the seam allowance as you approach the arm joint or you may simply deepen the seam at the opposite end i.e., neck point. Both processes reduce the slope of the shoulder. By trial and error you have to see which procedure gives the best effect.

(3) If a crosswise grain line is sagging, lift the sagging part by taking a deeper seam above it. If the *grain line* is curving up you have to do the opposite i.e., let out the seam above the rising part. Before making this adjustment, make sure that the off grain condition is not due to faulty cutting.

(4) To rectify a lengthwise *seam line* that curves or slants instead of hanging vertical, rip out the seam near the bulge (heavy bust, protruding back etc.) which is the cause of the trouble, and retack providing greater length and width for the bulge.

(5) To remedy an *off balance* condition, deepen the seam above the side which hangs down or let out the seam directly above the part which rises up.

(6) Fitting must be done over and over again until a perfect fit has been achieved. As mentioned earlier sleeve should be tacked to the armhole and tried on only after checking the fit of the blouse and sleeve separately and making the necessary adjustments.

8.6. FITTING TECHNIQUES

(1) Since the fitting is done wearing the blouse right side out, all changes needed will be marked on the right side, with chalk, pencil or pins. They are to be transferred to the wrong side later (after taking off the blouse) for making necessary adjustments or alterations.

(2) Fitting is usually done only on the right hand part of the garment. Changes marked on right hand side are to be transferred to the left hand side, so that the alterations are identical on both sides. If there are any imperfections they can be taken care of at the time of second fitting.

(3) If a seam or dart has to be shortened or lengthened, mark the termination point, preferably with a pin.

(4) If a seam has to be adjusted at one end to produce a tightening effect, take in the extra amount and pin on the right side. If a seam has to be loosened at one end, rip the seam at that part and re pin as a lapped seam or a plain seam (with reduced seam allowance) using pins applied on the right side.

(5) For side seam line that slants towards the back as in Fig.8.2e rip out the whole seam and re pin alter raising the back part above the front the required amount. (See Fig.8.2e₁)

8.7. SPECIFIC FITTING PROBLEMS IN A BLOUSE AND THEIR REMEDIES

We present below a number of fitting problems that you may encounter while fitting a blouse. The problems (a to k) are illustrated in Fig.8.2a to k. The remedial measures for each problem are also explained with the help of figures (Fig.8.2a₁ to k₁).

In these figures the solid lines indicate the original seam lines and the dotted lines the adjustments to be made. Since too many lines may confuse the reader, the cutting lines of blouse front, back and sleeve are not shown in the figures

Problem: a (Fig.8.2a): End of shoulder seam extends beyond arm joint: the sleeve cap slips down below the arm joint (if sleeve has been attached).

Cause: Shoulder seam is too long



Fig.8.2a

Remedy: (Fig.8.2a₁): Shorten the shoulder seam. (Mark the correct length with pencil or chalk or pin and draw new armhole curve connecting this point and under arm point as shown by dotted line).

Fig.8.2a₁

Problem b (Fig.8.2b): End of shoulder seam does not reach arm joint. If sleeve has been attached, the sleeve cap rides up.

Cause: Shoulder seam is too short.



Fig.8.2b

Remedy (Fig.8.2b₁): Lengthen the shoulder seam. (Mark the correct length and draw new armhole curve as indicated by dotted line).

Fig.8.2b₁

Problem c (Fig.8.2c):

- (1) Diagonal wrinkles pointing towards the neck point on shoulder.
- (2) The blouse rises above the shoulder at the arm joint but hugs the neck.
- (3) The crosswise grain line drops near armhole.

Cause: Shoulder slope of the blouse is insufficient.



Fig.8.2c

Remedy (Fig.8.2c₁,c₂): Increase the shoulder slope. (Re pin the shoulder seams making them slightly deeper as you approach the arm joint along the dotted line shown in (Fig.8.2c₁).

Fig.8.2c₁

If the blouse is tight near the neckline, rip out the seam at this point and repin along the dotted line shown in Fig.8.2c₂).

Fig.8.2c₂

Problem d (Fig.8.2d):

- (1) Diagonal wrinkles pointing towards the arm joint on shoulder.
- (2) The blouse rises above the shoulder at the neck point but hugs the arm joint.
- (3) The cross. wise grain line pulls up at armhole in front and back.

Cause: Shoulder slope of the blouse is too much.



Fig.8.2d

Remedy (Fig.8.2d₁,d₂): Reduce shoulder slope. (This can be done by reducing the seam allowance near the arm joint as shown in (Fig.8.2d₁) or by increasing the seam allowance near the neck point as in Fig.8.2d₂).

Fig.8.2d₁Fig.8.2d₂

Probleme (Fig.8.2e):

- (1) Wrinkles pointing towards the shoulder blades.
- (2) The blouse swings far out from the body at back and hugs the body in front.
- (3) The crosswise grain line curves up and the side seam slants towards the back.

Cause: Back length of blouse is insufficient due to protruding shoulder blades.



Fig.8.2e

Remedy (Fig.8.2e₁): Provide extra length for shoulder blades (Rip out and pin new shoulder seam reducing the seam allowance of back shoulder Rip out side seam and repin it lifting the back above the front at the side seam. Mark new armhole seam line, increasing

width of the back as shown. Front hemline near waistline should be trimmed along the dotted line).

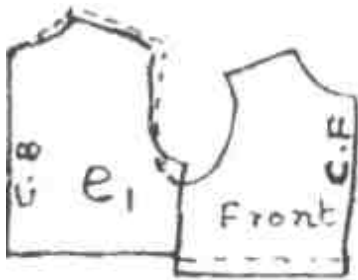


Fig.8.2e₁

Problem f (Fig.8.2f):

- (1) Wrinkles pointing towards the bust.
- (2) The underarm seam slants to the front.
- (3) The blouse swings from the body at centre front and hugs the body at back.
- (4) The crosswise grain line rises above the bust line.

Cause: Insufficient width or length or both for blouse front.



Fig.8.2f

Remedy (Fig.8.2f₁): Provide extra length and width near the bust line. (Rip out the side seam and introduce a side seam dart on the blouse front. If a side seam dart is already present, increase the width of the dart. Repin the side seam reducing the seam allowance on the blouse front. Increase the width of the waistline dart if necessary).



Fig.8.2f₁

Problem g (Fig.8.2g): The neckline gapes and sags in front.

Cause: Neck circumference of blouse is too much.



Fig.8.2g

Remedy (Fig.8.2g₁): Reduce neck circumference. (Reshape the centre front line, slightly curving in towards the top edge near neck as shown. If necessary, work a row of ease stitching (large stitches) on the neck seam line and pull up the bobbin thread until the neckline fits smoothly).



Fig.8.2g₁

Problem h (Fig.8.2h): Pulling wrinkles pointing towards front sleeve cap.

Cause: Front sleeve cap seam is too deep.



Fig.8.2h

Remedy (Fig.8.2h₁): Reduce depth of front sleeve cap seam as shown

Fig.8.2h₁

Problem i (Fig.8.2i): Pulling wrinkles pointing to the top of the sleeve.

Cause: Sleeve cap height is too short.



Fig.8.2i

Remedy (Fig.8.2i₁): Increase sleeve cap height as shown by dotted lines.

Fig.8.2i₁

Problem j (Fig.8.2j): Pulling wrinkles pointing to under arm point.

Cause: Sleeve cap height is too much.



Fig.8.2j

Remedy (Fig.8.2j₁): Reduce sleeve cap height as shown.

Fig.8.2j₁

Problem k (Fig.8.2k): Sleeve pulls and wrinkles across upper arm.

Cause: Sleeve width is insufficient at upper arm.



Fig.8.2k

Remedy (Fig.8.2k₁): Increase sleeve width at upper arm as shown.

Fig.8.2k₁

8.8. LET US SUM UP

In this unit, we

- Learnt how to check the fit of a garment and how to rectify those problems
- Learnt standards of a fit

8.9. LESSON END ACTIVITIES

- The distance students may select a person among themselves to check the fit of a garment and if any problem arise can think over themselves to rectify those problems using the study

8.10 POINTS FOR DISCUSSION

- Analyze certain fitting problems with remedies.
- Analyze standards of fit
- Analyze how to prepare a blouse for fitting.
- Analyze fitting techniques

8.11 REFERENCES

- Practical clothing construction, Part I and II, Mary Mathews, Cosmic Press, Chennai (1986).

LESSON – 9: PATTERN ALTERATION

CONTENTS

- 9.0. Aims and Objectives
- 9.1. Importance of pattern alteration
- 9.2. General principles for pattern alteration
- 9.3. Common pattern alteration in a blouse
- 9.4. Let us sum up
- 9.5. Lesson end activities
- 9.6. Points for discussion
- 9.7. References

9.0 AIMS AND OBJECTIVES

- In this unit we have discussed the importance, principles and common pattern alteration in a blouse.

After reading this unit you should be able to

- Identify the techniques for pattern alteration.

9.1. IMPORTANCE OF PATTERN ALTERATION

Importance of altering patterns: if a garment is cut after the pattern is altered to fit your figure, there is no danger of wasting expensive fabric and spoiling the garment. Fitting the garments also will be much easier because there will not be major alterations to be made at this stage. Moreover some alterations cannot be satisfactorily made after the garment is cut. Hence it is essential that you perfect your pattern by making the necessary alterations before using it for cutting out the actual garment.

9.2. GENERAL PRINCIPLES FOR PATTERN ALTERATION

(1) As far as possible make changes within the pattern by slashing and spreading or slashing and lapping. Patterns can also be altered by redrawing the edges of the pattern. (This is the method adopted for altering garments at the time of fitting.) But the first method is by far the best in altering paper patterns.

(2) To preserve the original grain line, make all slashes and folds parallel or perpendicular to the grain line (to centre front line, centre back line etc).

(3) Where there are darts, make changes between the tip of the dart and the outside edge.

(4) If an alteration in length is made along one edge of the pattern, take care to make an identical alteration in the adjoining edge. For example, if back shoulder seam is shortened the front shoulder seam should also be shortened.

(5) When tucks or darts are used for making a pattern smaller, remember that the width of these should be just half the amount to be removed.

(6) When decreasing or increasing the width of pattern pieces, if only half the pattern (half back or half front) is used, subtract or add only one fourth of the total adjustment to be made. For example, if waist measurement has to be increased by one inch, add $\frac{1}{4}$ " to the half back pattern and the same amount to the front pattern. If only a front or back section needs adjustment, add or minus half the amount of the adjustment to the respective section.

(7) When the pattern alteration involves slashing and spreading, it is necessary to keep a sheet of paper beneath and to pin or stick to it the spread-out parts so that they will thereafter remain in position. On spreading or lapping after slashing, some edges of the pattern become jagged. These must be trimmed after drawing the new seam lines.

9.3. COMMON PATTERN ALTERATION IN A BLOUSE (FIG.9.1)

You must analyse your fitting problems to decide which of the following alterations are needed in your blouse. All the principles of pattern alteration should be borne in mind while doing the alterations.

Shortening the blouse (Fig.9.1a): To shorten, make a tuck half as wide as the amount to be reduced, and pin. The tuck should be made about $2\frac{1}{2}$ " above the waist line at right angles to centre front or centre back line. Redraw new straight side seam line, as shown in the figure.

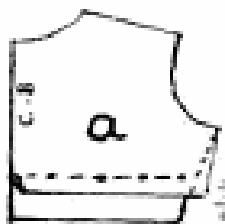


Fig.9.1a

Lengthening the blouse (Fig.9.1b): To lengthen, slash the pattern $2\frac{1}{2}$ inches above the waist line at right angles to centre front. Now spread the pattern the necessary amount and pin or stick each edge to a strip of paper kept underneath. Redraw side seam line.

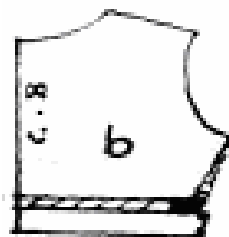


Fig.9.1b

Lengthening the shoulder seam: Alteration for broad shoulders (Fig.9.1c): Slash down from midpoint of shoulder seam to a level below the armhole and then slash across at right angles to the first slash almost to the side seam. Now spread the slashed edges apart, the

correct amount and stick or pin a paper underneath to maintain this position. Draw a new seam line from neck line to armhole.

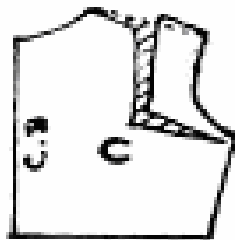


Fig.9.1c

Shortening the shoulder seam: Alteration for narrow shoulders (Fig.9.1d): Slash pattern as above and overlap the edges of the slash, the necessary amount and pin. Draw new shoulder seam line straight from neckline to armhole.

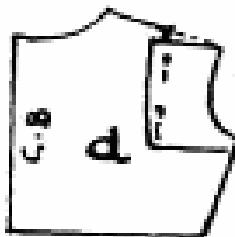


Fig.9.1d

Decreasing shoulder slope: Alteration for square shoulders (Fig.9.1e): Slash from the shoulder downwards (as above) then across through the side seam. Place paper below the slash and raise the entire armhole section the desired amount. Pin or stick the pattern to the paper. Draw new shoulder seam line as shown.

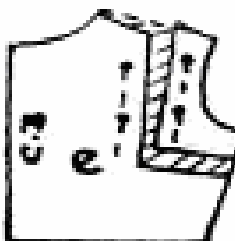


Fig.9.1e

Increasing the shoulder slope: Alteration for sloping shoulders (Fig.9.1f): Slash the pattern as you did for decreasing the shoulder slope. Lower the entire armhole section, overlapping along the crosswise slash and pin. Draw new shoulder seam line as shown.

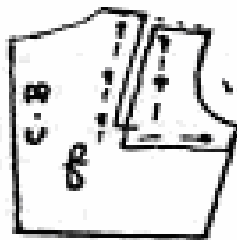


Fig.9.1f

Increasing back length: Alteration for round shoulders (Fig.9.1g): Slash the back pattern about 4" below neckline, from centre back to armhole, seam line. Spread the slash apart the necessary amount, insert paper underneath and pin in position. Redraw centre back line straight, and neckline and shoulder seam to original size as shown by dotted lines.



Fig.9.1g

Decreasing back length: Alteration for hollow back (Fig.9.1h): Slash the back pattern as above and overlap edges of slash the necessary amount tapering to the armhole line. Redraw the centre back line and other seam lines which got altered while overlapping the edges.

Shortening centre front length: Alteration for hollow chest: Slash the front pattern across from centre front to armhole about 4" below the neckline and lap the slashed edges as for decreasing back length (Refer Fig.9.1h).

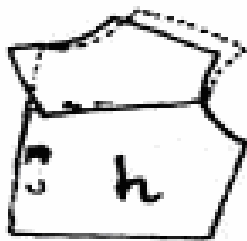


Fig.9.1h

Increasing length and width of front pattern: Alteration for large bust (Fig.9.1i): Make length wise and crosswise slashes cutting through the centre of dart. Spread the pattern the necessary amount in each direction (vertical and horizontal) and pin it to paper. Mark new dart point half way between the tips of the separated dart lines and redraw wider darts.

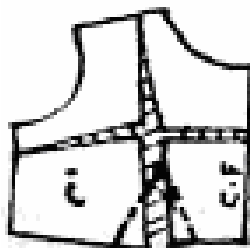


Fig.9.1i

Decreasing neck line measurement: Alteration for neck line that sags in front (Fig.9.1j): Pin small even sized darts at regular intervals on the neck edge of the pattern.



Fig.9.1j

Increasing waist measurement: Add to each side seam edge at the waist line one fourth the total amount of increase desired, and draw new side seam lines.

Decreasing waist measurement: Remove one fourth the amount of decrease desired from each seam edge at the waist line, and draw new side seam lines.

Lengthening sleeve cap (Fig.9.1k): Slash the pattern crosswise as shown and spread the pattern the necessary amount.

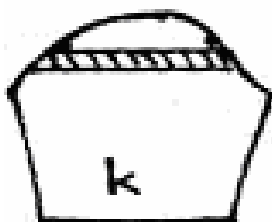


Fig.9.1k

Increasing width of sleeve cap: Alteration for large upper arm (Fig.9.1L): Slash the sleeve pattern vertically down from centre of sleeve cap to lower edge. Make a crosswise slash at fullest part of sleeve cap from seam line to seam line. Spread apart each side of the pattern, the necessary amount. This will cause the edges of the slash across the Sleeve cap to overlap. Insert paper under slash extending beyond the sleeve cap line and pin or stick in position. Redraw sleeve cap line to adjust for the amount decreased due to the overlapping.



Fig.9.1L

Increasing or decreasing length of sleeves: To shorten or lengthen short sleeves, alteration can be made at the lower edge.

9.4. LET US SUM UP

In this unit, we

- Learnt the techniques of pattern alternation.

9.5. LESSON END ACTIVITIES

- The distance students can have a practical experience by carrying out trails in making pattern alternation.

9.6. POINTS FOR DISCUSSION

- Analyze the techniques of pattern alternation.

9.7. REFERENCES

- Practical clothing construction, Part I and II, Mary Mathews, Cosmic Press, Chennai (1986).

LESSON – 10: PATTERN GRADING - MANUAL

CONTENTS

- 10.0. Aim and Objective
- 10.1. Pattern grading
- 10.2. Definition
- 10.3. Types
- 10.4. Manual grading
 - 10.4.1. Manual grading the back bodice
 - 10.4.2. Manual grading the front bodice
 - 10.4.3. Manual grading of basic sleeve
 - 10.4.4. Manual grading of basic collar
- 10.5. Let us sum up
- 10.6. Lesson end activities
- 10.7. Points for discussion
- 10.8. References

10.0. AIMS AND OBJECTIVES

- In this unit we have discussed the importance, principles and common pattern alternation in a blouse. This unit includes pattern grading and its types.

After reading this unit you should be able to

- Identify the techniques for pattern alternation.
- Grade patterns either manually or master grades for basic front, back, sleeve and collar.

10.1. PATTERN GRADING

It is very much helpful in the garment industry starting from a pattern drafted from a particular size you can make patterns of other sizes by grading.

10.2. DEFINITION

Grading is a method of enlarging or reducing a pattern of a particular size proportionately to some other size.

10.3. TYPES

- Manual grades
- Master grades

10.4. MANUAL GRADING

10.4.1. MANUAL GRADING THE BACK BODICE: (FIG.10.1A)

Take the 32" size back bodice pattern (without seam allowance) and trace its outline on a larger sheet of paper.

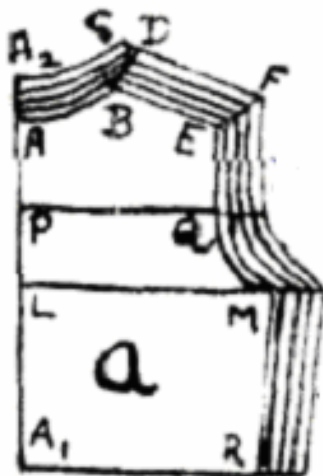


Fig.10.1a

Extend the centre back line $A_1 A$ by one inch and mark four points at $1/4$ intervals. (These represent bust sizes 32" to 40" at 2" intervals), Label the last point as A_2 .

Mark C one inch vertically above B . Mark $CD = 1/2$ " and connect DB . Divide DB into 4 equal parts, then connect these points to the points marked above centre back line as shown.

Now draw DF parallel to the shoulder line BE , with $DF = BE + 1$ ". This will be the shoulder line for 40" size.

Connect F to the original shoulder point E . Mark three points which divide EF into four equal parts, and join them to the corresponding points on BD by lines which will be parallel to DF .

Next, draw the horizontal line LM from the underarm point and mark P as the midpoint of AL .

Draw PQ as shown. Extend this line one inch outward and mark 4 points $1/4$ " apart.

Now extend bust line LM and waist line $A_1 R$ and mark points $1/2$ " apart. Connect all the points marked as shown in the figure

10.4.2. GRADING THE FRONT BODICE: (FIG.10.1B)

When grading front bodice, the bust line is extended to both sides (beyond centre front and beyond side seam) $3/8$ " is added beyond centre front and $1/8$ " beyond side seam for each size increase. There is no grading around the armhole. The shoulder lengthens $1/8$ " and rises J " for each size increase. The neck grade rises $1/8$ " and extend $3/8$ " outward on the centre front.

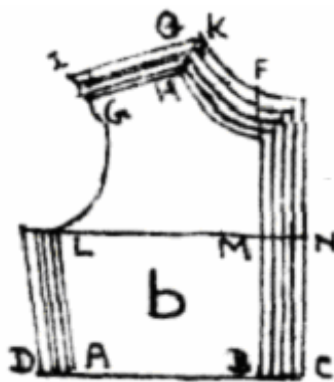


Fig.10.1b

Take the 32" size front bodice pattern and trace its outline on a larger sheet of paper.

Extend waist line AB beyond B and mark four points $\frac{3}{8}$ " apart. Label the last point as C.

Similarly extend bust line LM to LN and mark points $\frac{3}{8}$ " apart on MN.

Connect CN and corresponding points and extend these four lines upwards as shown. These are the centre front lines of the various sizes.

Extend line BA beyond A and mark four points $\frac{1}{8}$ " apart. Label the last point as D.

Similarly extend line ML and mark four points $\frac{1}{8}$ " apart.

Connect all the corresponding points to form the side seam lines of the various sizes.

On the shoulder line, rule vertical lines upwards from G and H and mark off four points at J" intervals along each of these lines.

Label the highest points as P and Q respectively. Connect PQ and extend it on to either side by and mark points I and K.

IK is the shoulder line of size 40. Connect GI and HK as shown. This gives the angle for shoulder increase.

Rule the shoulder lines for the in between sizes by connecting the points marked earlier, and extending them on to either side as shown

Extend centre front line upwards and mark off four points $\frac{1}{8}$ " apart.

Label the highest point as F and connect KF as shown.

Connect corresponding points to form the neck lines and extend the lines to meet the centre front lines.

10.4.3. GRADING OF BASIC SLEEVE

Take the sleeve pattern of bust size 32" and trace its outline on a sheet of paper.

Extend line AB one inch beyond B to B₁, and one inch beyond A to A₁.

Between A₁ and B₁ mark points at $\frac{1}{4}$ inch intervals. Extend the centre line one inch beyond C to C₁.

On C₁, mark points $\frac{1}{4}$ inch apart.

Extend line EF one inch beyond F to F₁ and one inch beyond E to E₁.

Between E₁ and F₁ also mark points $\frac{1}{4}$ inch apart.

Now connect the respective points as shown in Fig.10.1c.

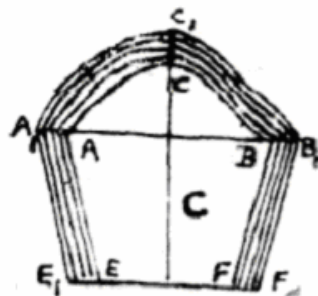


Fig.10.1c

The outermost pattern is that of 40 inch size, next one 38 size, next 36" size and so on.

10.4.4. GRADING OF BASIC COLLAR

Take the collar pattern of bust size 32 inch and trace its outline on a sheet of paper.

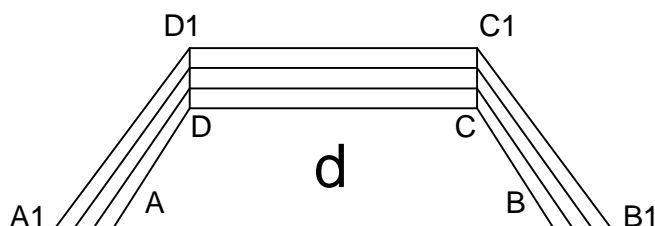


Fig.10.1d

Extend the line A to A1, B to B1, C to C1 and D to D1 in Fig.10.1d.

Between A A1, B B1, C C1 and D D1 mark points at $\frac{1}{4}$ inch intervals.

Connect the respective points as shown in Fig.10.1d.

The outermost pattern is that of 40 inch size, next one 38 size, next 36 size and so on.

10.5. LET US SUM UP

In this unit, we

- Discussed the types of grading, manual grades for basic front, back, sleeve and collar.

10.6. LESSON END ACTIVITIES

- The distance students can have a practical experience by carrying out trails in making pattern grading.

10.7. POINTS FOR DISCUSSION

- Evaluate the manual grading techniques by grading a particular garment style for different sizes.

10.8. REFERENCES

- Practical clothing construction, Part I and II, Mary Mathews, Cosmic Press, Chennai (1986).

LESSON – 11: MASTER PATTERN GRADING

CONTENTS

- 11.0. Aim and Objective
- 11.1. Master Pattern grading - Introduction
- 11.2. Master grades
 - 11.2.1. The basic whole back
 - 11.2.2. The basic front
 - 11.2.3. The basic sleeve
 - 11.2.4. The basic collar
- 11.3. Let us sum up
- 11.4. Lesson end activities
- 11.5. Points for discussion
- 11.6. References

11.0. AIMS AND OBJECTIVES

- In this unit we have discussed master pattern grading for basic back, basic front, basic sleeve and collar.

After reading this unit you should be able to

- Master grades for basic front, back, sleeve and collar.

11.1. MASTER PATTERN GRADING - INTRODUCTION

The girth and length grading increments for the body have been determined according to the data provided by the survey. The resultant increments and their applications now provide the foundations for deriving the grades of other basic components.

11.2. MASTER GRADES

The following examples demonstrate the applications of the system to standard types of block patterns. These are the basic patterns from which most outerwear garment patterns are developed and each example provides:

- 1) Where necessary, an illustrated introduction to the principles involved in grading the demonstration pattern.
- 2) The increments used, and their locations.
- 3) The net of grading increments required for one size up and one size down from the base size.
- 4) Instructions regarding the common and other axes required in relation to the grading position of the pattern.
- 5) Grading instructions accompanied by illustrations showing each successive stage. The line sectors to mark after each move denoted by a thickened line.

- 6) An example of the finished grade is shown together with the vectors used for checking accuracy.
- 7) The first five groups of examples show the applications the dynamic neck to waist grading method and in group six, the static method is demonstrated.

The first examples demonstrate the basic body and derived grades, and these grades are central to the entire system. All of the other grades for bodies, sleeves, lapels and collars are based on these examples.

11.2.1. THE BASIC WHOLE BACK

This first grading example utilises the following increments:

B: The total width grade from the centre back to the side seam.

D: Across back. This is equal to increments F plus G.

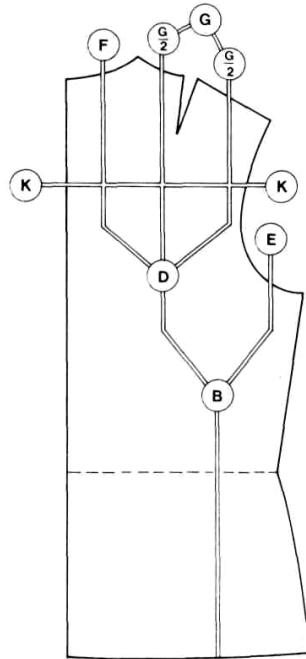
E: Side section.

F: Neck width.

G: Shoulder length in two sections ($G/2 + G/2$).

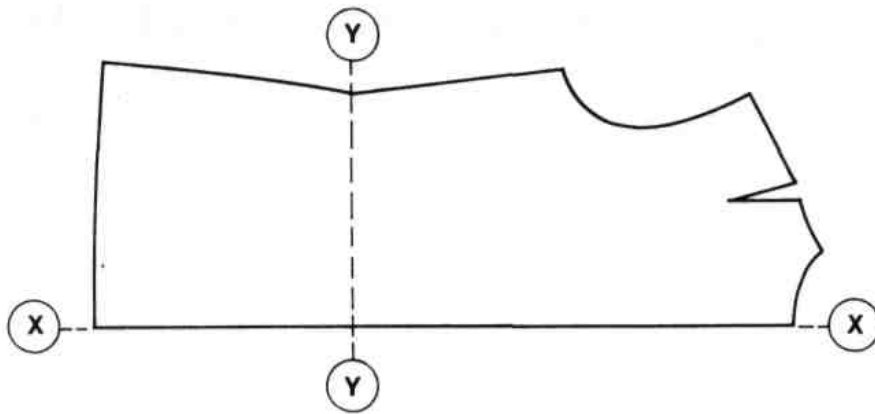
K: Armhole depth.

Fig.11.1 illustrates the locations of these increments with Fig.11.2 showing the grading axes and Fig.11.3 the increment net for this grade.



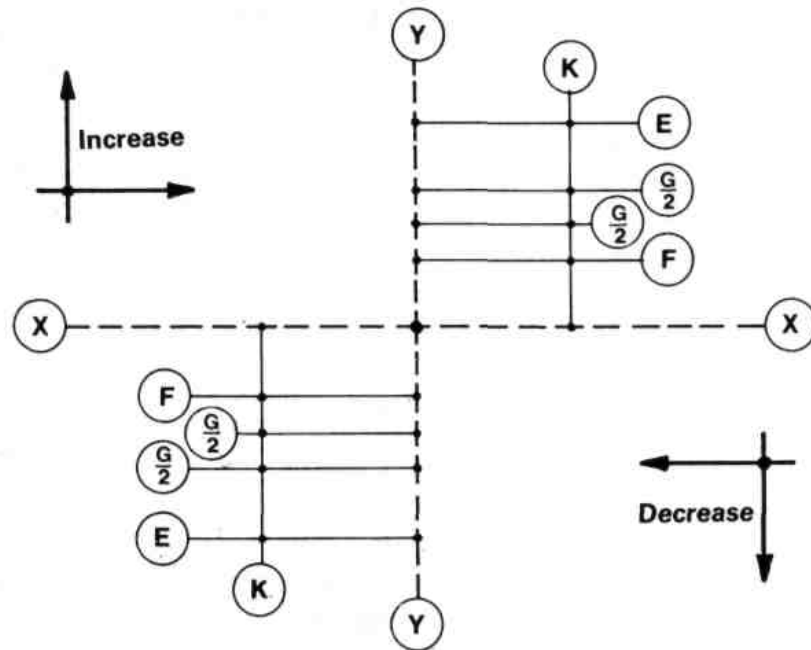
Grading increments for basic whole back.

Fig.11.1



Grading axes.

Fig.11.2



Increment net

Fig.11.3

Grading instructions: BASIC WHOLE BACK

Stage 1: align pattern on X and Y axes (Fig.11.4)

- Move on Y axis to second G/2
- Mark part of armhole.

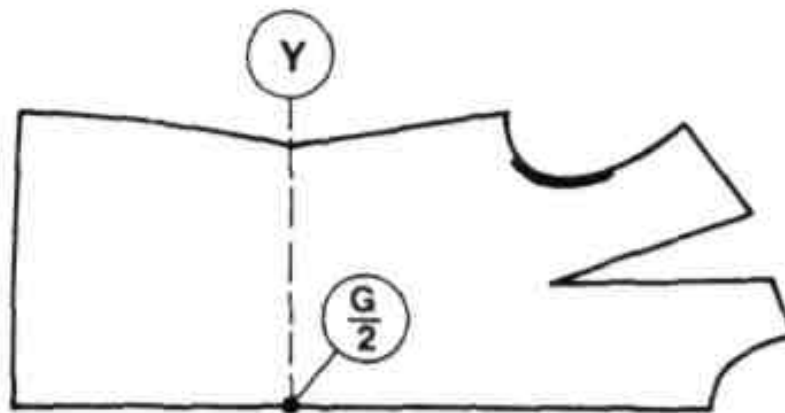


Fig.11.4

Stage 2: continue on Y axis to E (Fig.11.5)

- Mark side seam

- Complete armhole to side seam
- Complete hem.

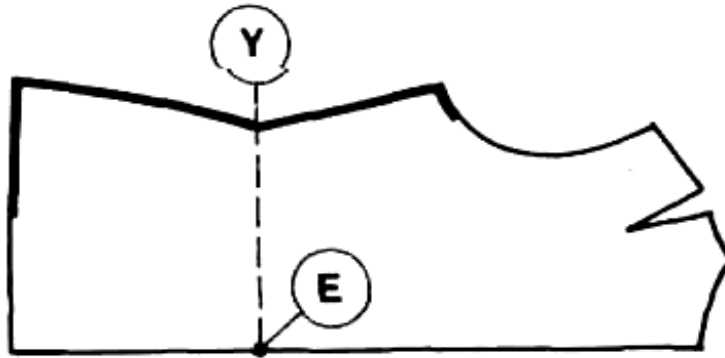


Fig.11.5

Stage 3: re-align on X axis and align the Y axis of the pattern to the relevant K line (Fig.11.6)

- Mark corner of centre back and neck.

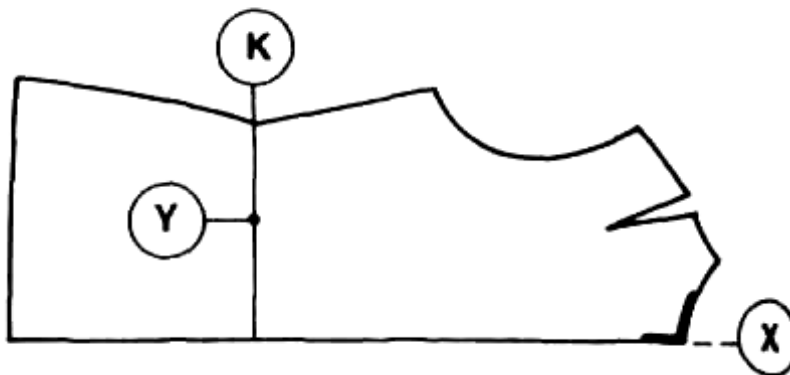


Fig.11.6

Stage 4: remain on K line (Fig. 11.7)

- Move on K axis to F
- Complete neckline
- Mark start of shoulder.

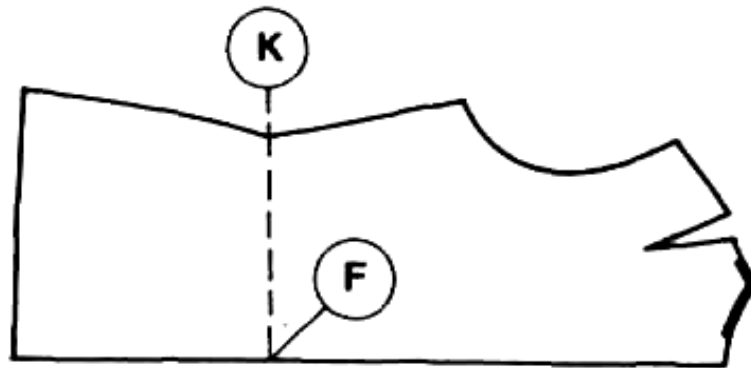


Fig.11.7

Stage5: remain on K line (Fig.11.8)

- Move to first G/2
- Complete first part of shoulder
- Mark dart
- Mark start of second part of shoulder.

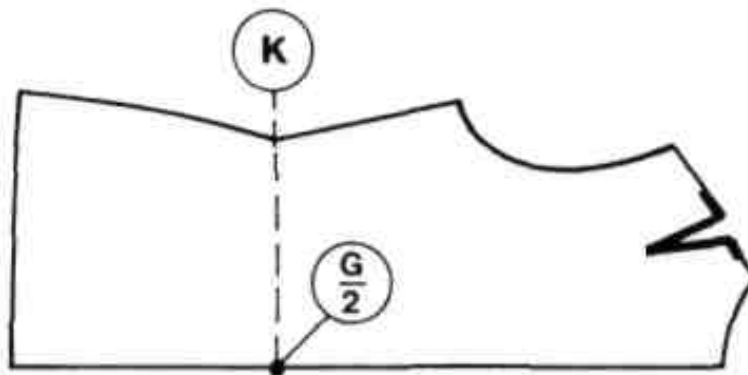


Fig.11.8

Stage6: remain on K axis (Fig. 11.9)

- Move to second G/2
- Complete shoulder

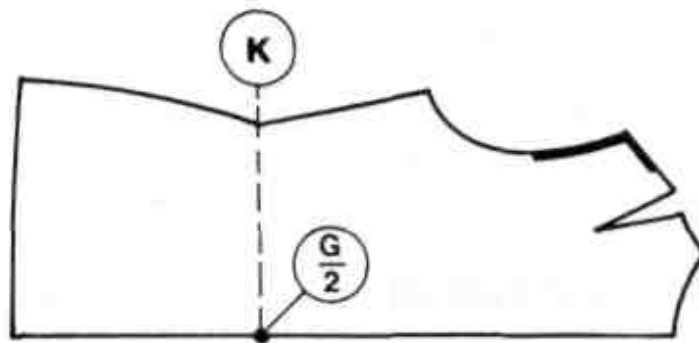
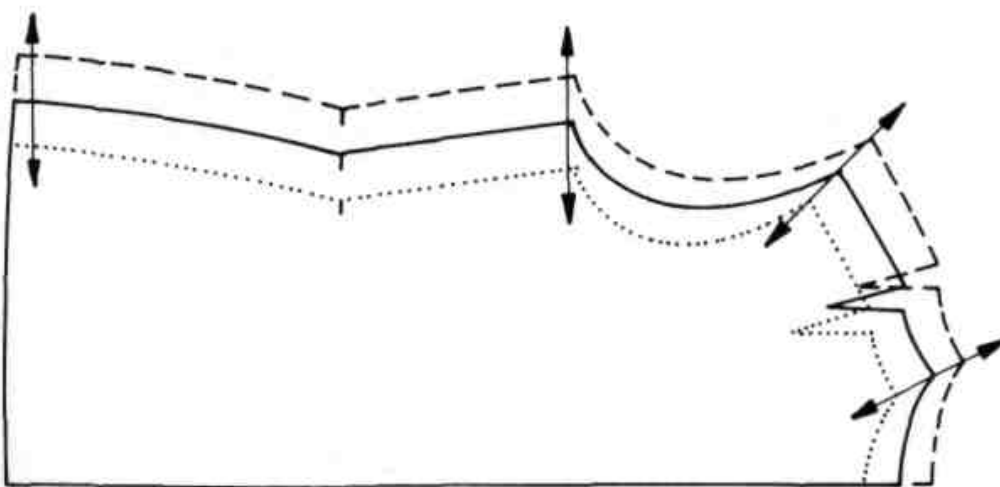


Fig.11.9



Grade for basic back

11.2.2. THE BASIC FRONT

This is the basic grade for all fronts with bust darts and the example is demonstrated on a standard block front with the bust dart coming from the shoulder. The increments used for this grade are:

- C: The total grade from the front edge to the side seam.
- E: Side section.
- F: Neck width.
- G: Shoulder length in two sections ($G/2 + G/2$).
- H: Width of breast.
- I: Front edge to bust point on bust line.
- I: First side of the bust point.
- J: Bust point to armhole on bust line.
- L: Second side of the bust point.

M: Front neck point to bust line. This increment is equal to increments K plus and is applied as one unit for the dynamic neck to waist grade.

THE BUST DART GRADE

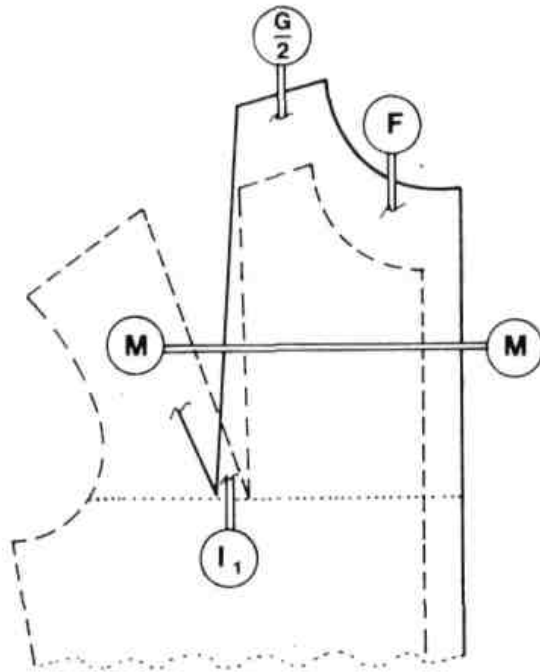
Apart from changing the bust girth, the bust dart grade also affects two other dimensions:

- 1) The vertical length from the front neck point to the bust line. Increment M is used for this purpose.
- 2) The depth of the front armhole as measured from the armhole base to the shoulder point. This change in depth is caused by increment K which is I the resultant quantity after the application of increment M.

The principles of this particular grade are:

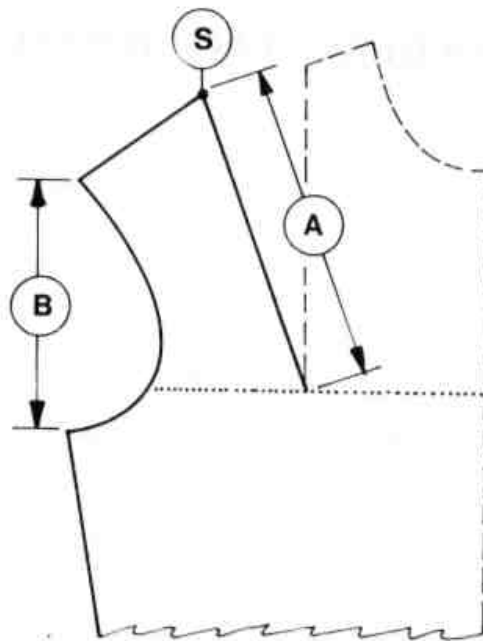
- 1) Increment $I = F + G/2 + I$, affects the total width I on the bust line from the front edge to the bust point. This side of the bust dart receives increment I, at the bust point (Fig. 11.10).
- 2) The other side of the bust dart receives increment J_1 at the bust point and this point is joined to the intersection of the shoulder and bust dart line at point S (Fig.11.11). The length of this connecting line A. is changed by increment M so as to equal the change in length of the other side of the bust dart.
- 3) The angle of the shoulder line (alpha) relative to the bust dart line remains unchanged irrespective of how much the connecting line A is pivoted around point S.
- 4) When J, is applied at the bust point and increment M is applied along line A. the result is that the armhole depth is affected by about two-thirds of the value of M. (This result can be calculated trigonometrically.)
- 5) Thus when M is applied to the length of the bust dart and J, at the bust point, increment K is generated automatically (Fig. 11.12).
- 6) The resultant quantity for increment K ensures that the depths of the-front and back armholes change by the same amount. As increment K is also applied to the sleeve head, the relationships between the components is accurately maintained.

The distances shown in the illustrations accompanying this section have been exaggerated for the purposes of clarity.



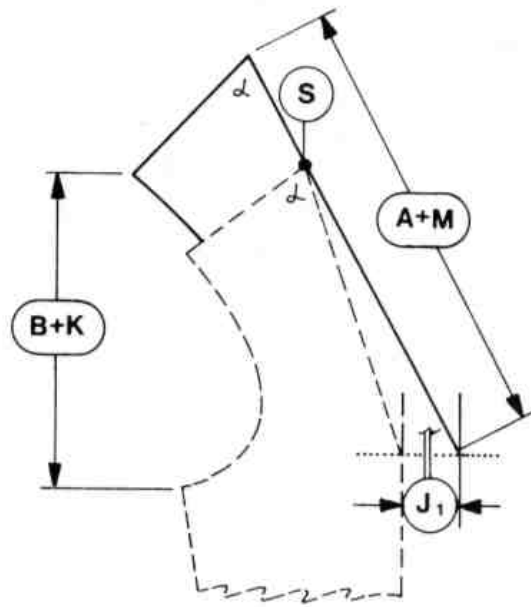
Grade for first side of bust dart

11.10



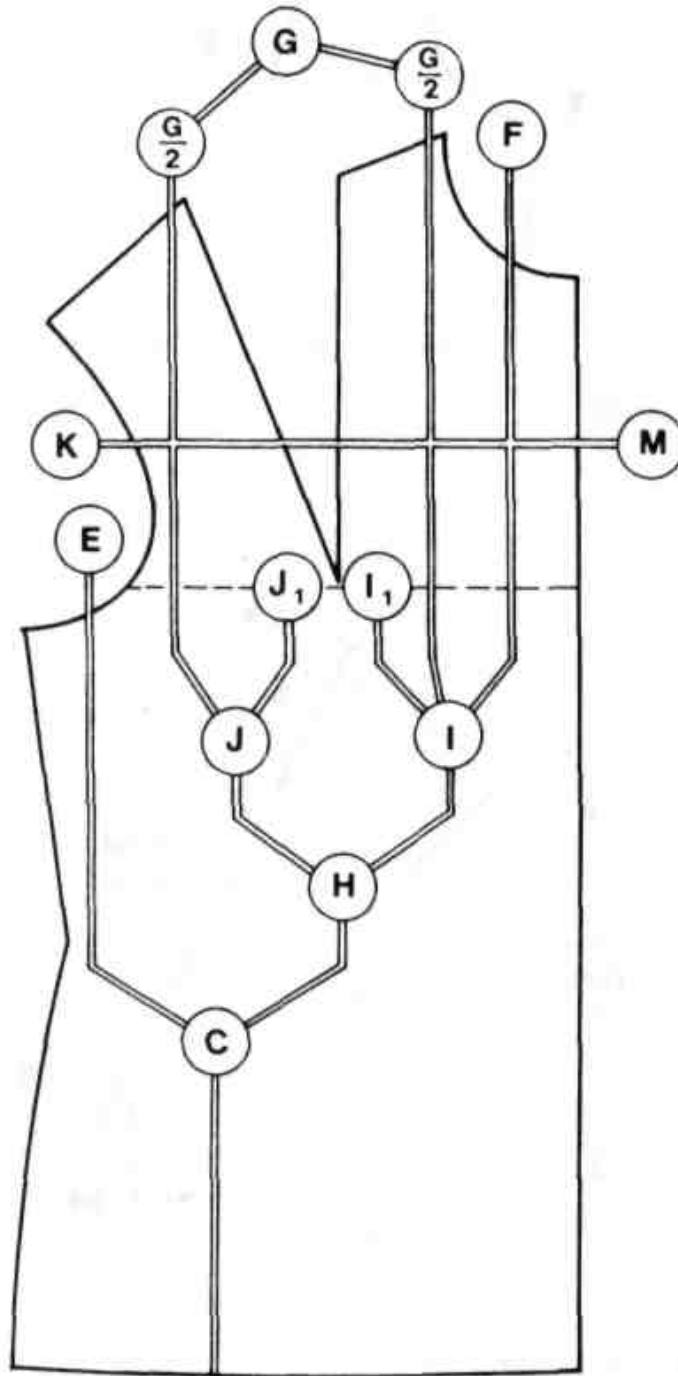
Length A and Depth B

Fig.11.11



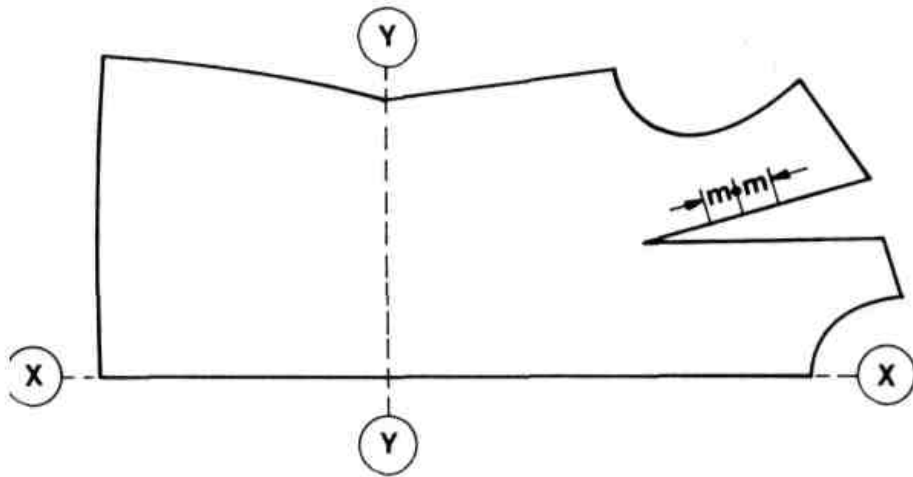
The generation of increment K

Fig.11.12

Grading Instruction: THE BASIC FRONT

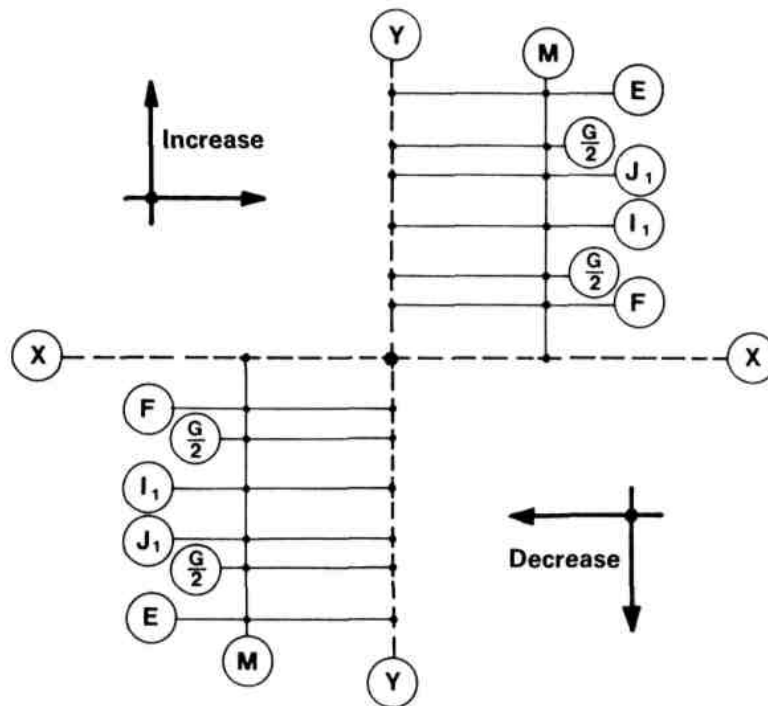
Grading increments for basic front

Fig.11.13



Grading axes

Fig.11.14



Increment net

Fig.11.15

Stage 1: mark central M on bust dart line (Fig.11.16)

- M to M1 = one size increase
- M to M2 = one size decrease.

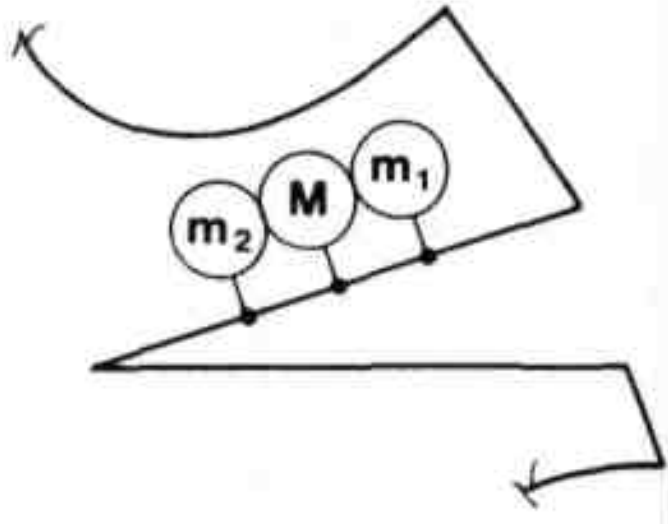


Fig.11.16

Stage 2: align pattern on X and Y axes (Fig.11.17)

- Mark front edge
- Mark hem corner.

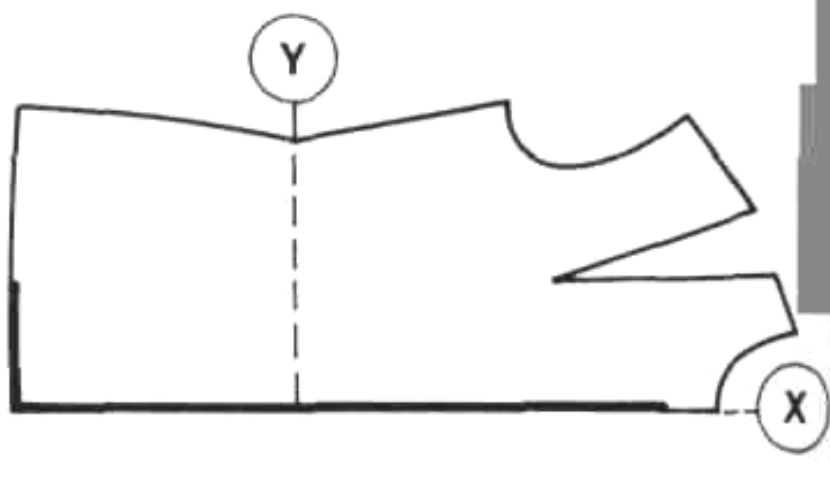


Fig.11.17

Stage 3: remain on Y axis. (Fig.11.18)

- Move to I₁, mark new bust point

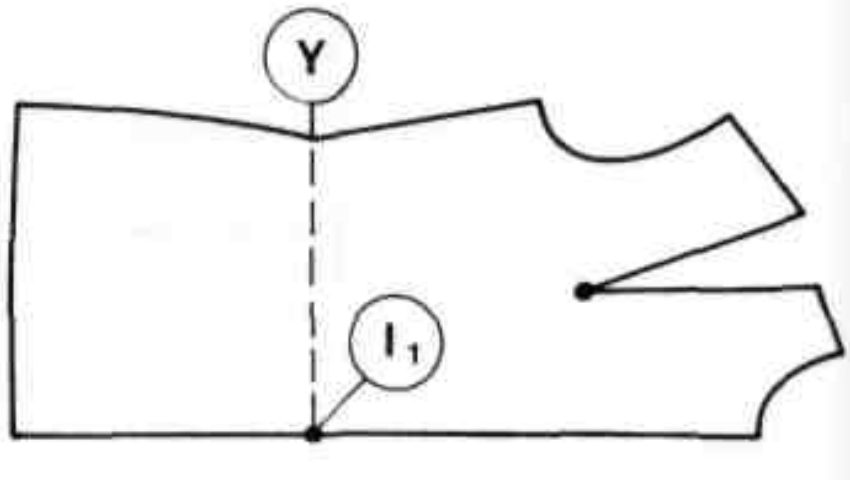


Fig.11.18

Stage 4: remain on Y axis. (Fig.11.19)

- Move to J_1 , mark point S

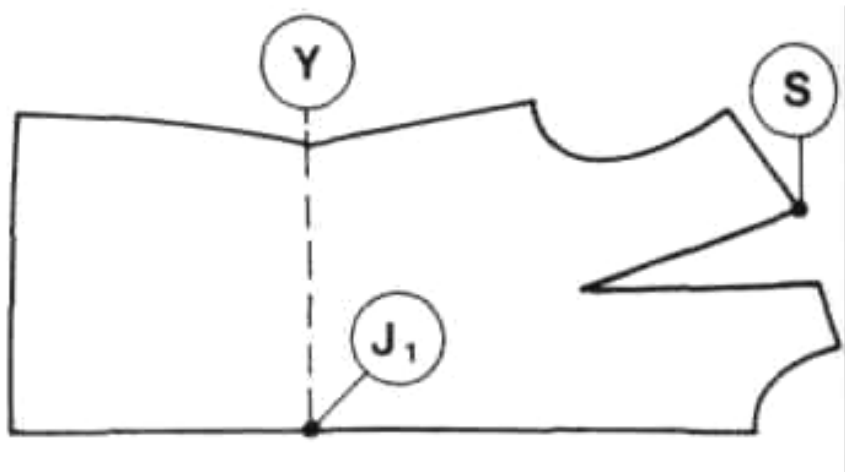


Fig.11.19

Stage 5: remain on Y axis (Fig.11.20)

- Move to second $G/2$.
- Mark armhole from across chest line to about 3 cm from side seam.

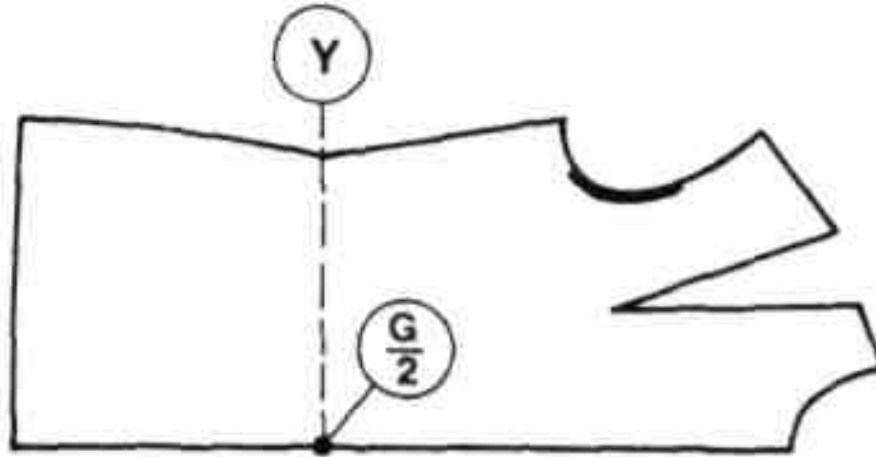


Fig.11.20

Stage 6: remain on Y axis (Fig.11.21)

- Move to E
- Mark side seam
- Complete base of armhole
- Complete hem.

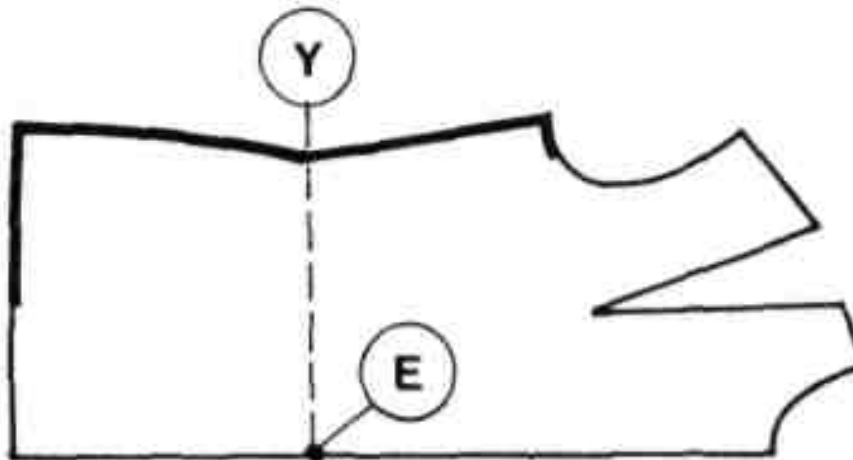


Fig.11.21

Stage 7: align Y axis to relevant M line (Fig. 11.22)

- Mark corner of neck and front edge.

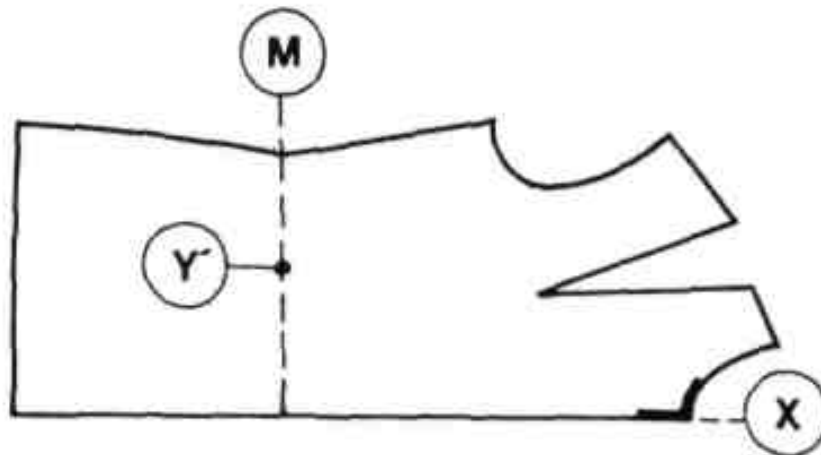


Fig.11.22

Stage 8: remain on M line (Fig.11.23)

- Move to F
- Complete neck
- Mark start of shoulder.

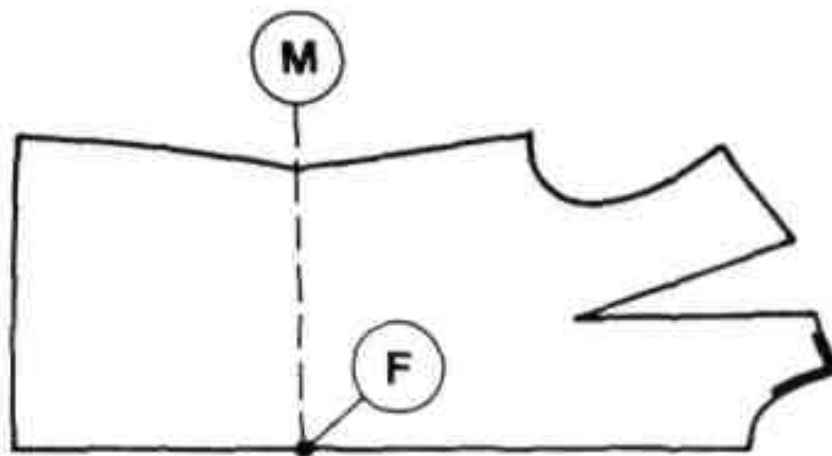


Fig.11.23

Stage 9: remain on M line I (Fig.11.24)

- Move to first G/2
- Complete first section of shoulder
- Mark corner of bust dart and shoulder.

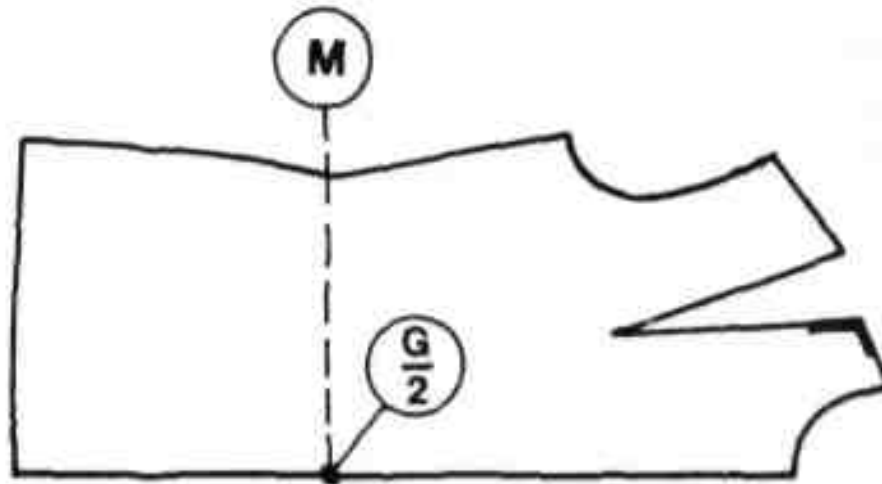


Fig.11.24

Stage 10: use the pattern to join shoulder corner (Stage 9) to bust point (Fig.11.25)

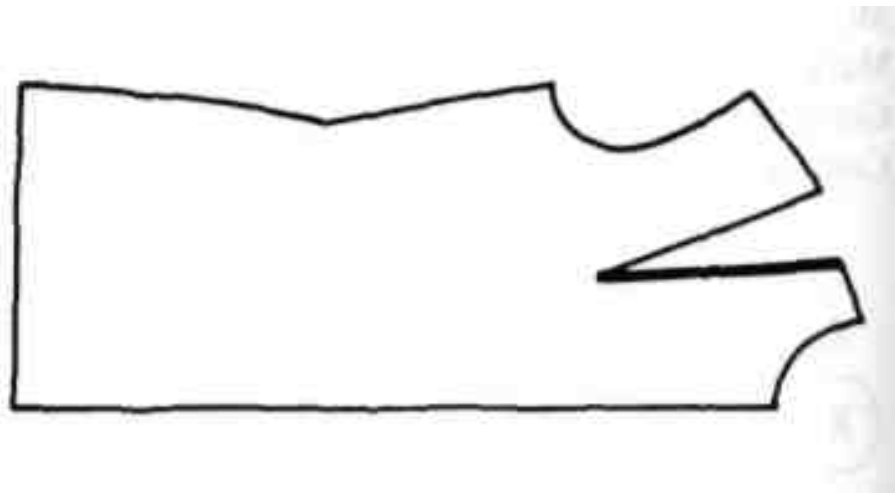


Fig.11.25

Stage 11: align pattern from bust point to point S (marked in Stage 3) (Fig.11.26)

- Join bust point to this point
- Mark central M
- Mark relevant M.

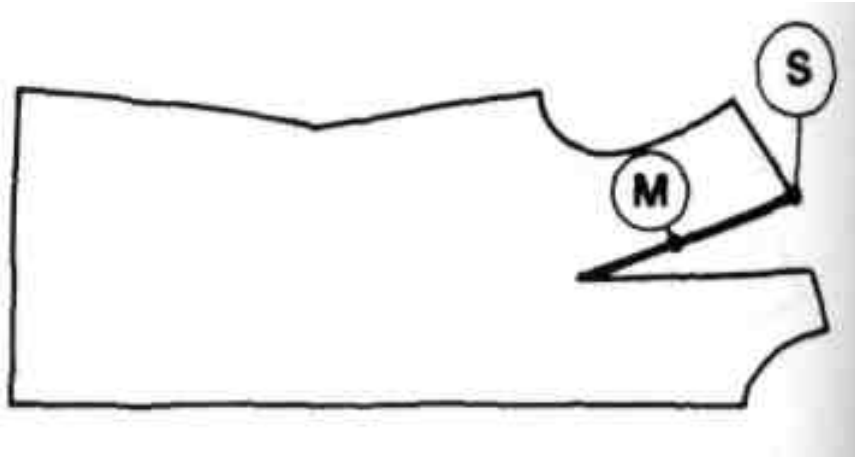


Fig.11.26

Stage 12: move pattern along this line and align central M with relevant M (Fig.11.27)

- Move towards shoulder to increase
- Move towards bust point to decrease
- Mark start of shoulder.



Fig.11.27

Stage 13: move pattern by distance $G/2$ parallel to bust dart line (Fig.11.28)

- Towards side to increase
- Towards front to decrease
- Complete shoulder and armhole

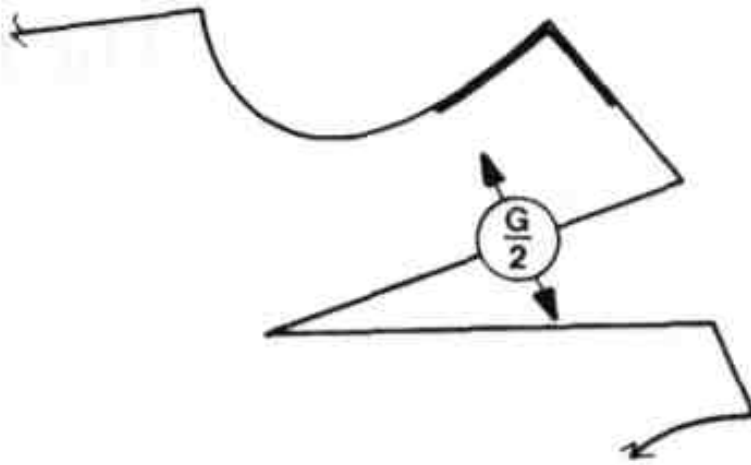
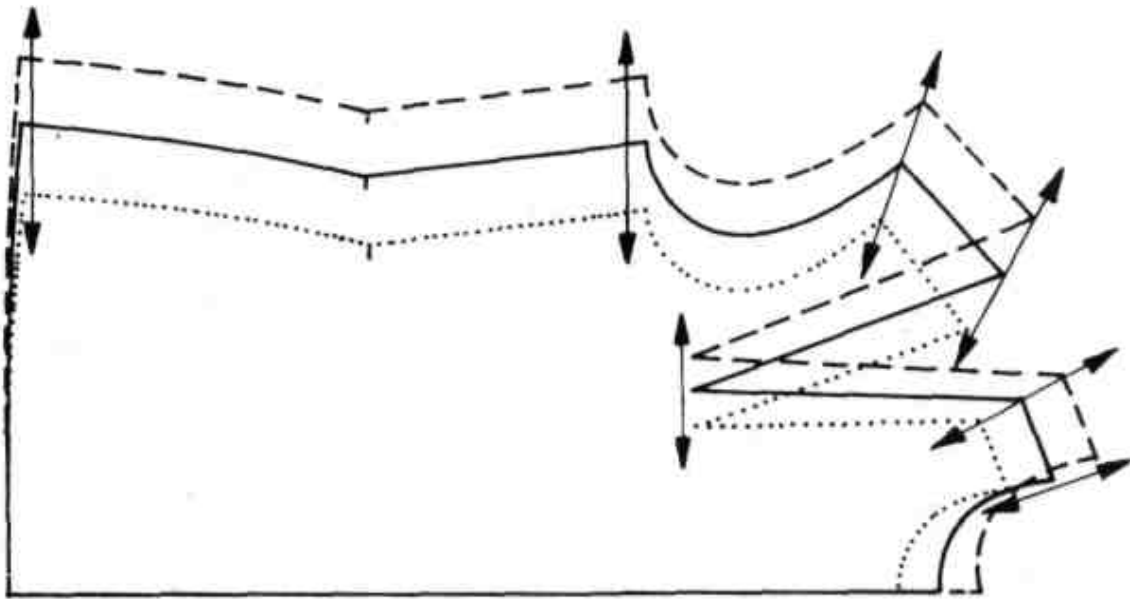


Fig.11.28



Grade of basic front

11.2.3. THE BASIC SLEEVE

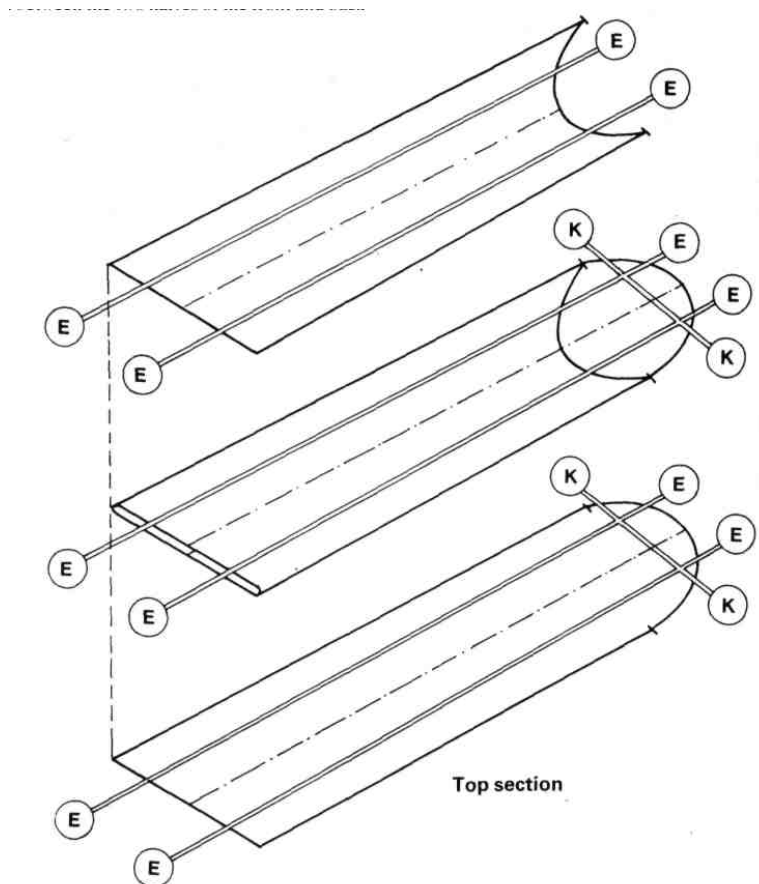
The one-piece straight sleeve is the first of the basic derived grades where all of the necessary grading increments are obtained from the armhole and side section grade of the body.

When allocating the sleeve width increments, it is essential to maintain two relationships (Fig.11.29)

- 1) That between the top and bottom halves of the sleeve.
- 2) That between the two halves of the front and back sleeves

This is irrespective of whether the side seam of the garment has been displaced from the centre of the armhole. In these instances, the same allocation of the armhole width grade $2E$, on the side sections of the I back and front, should be used for the related sleeve I sections.

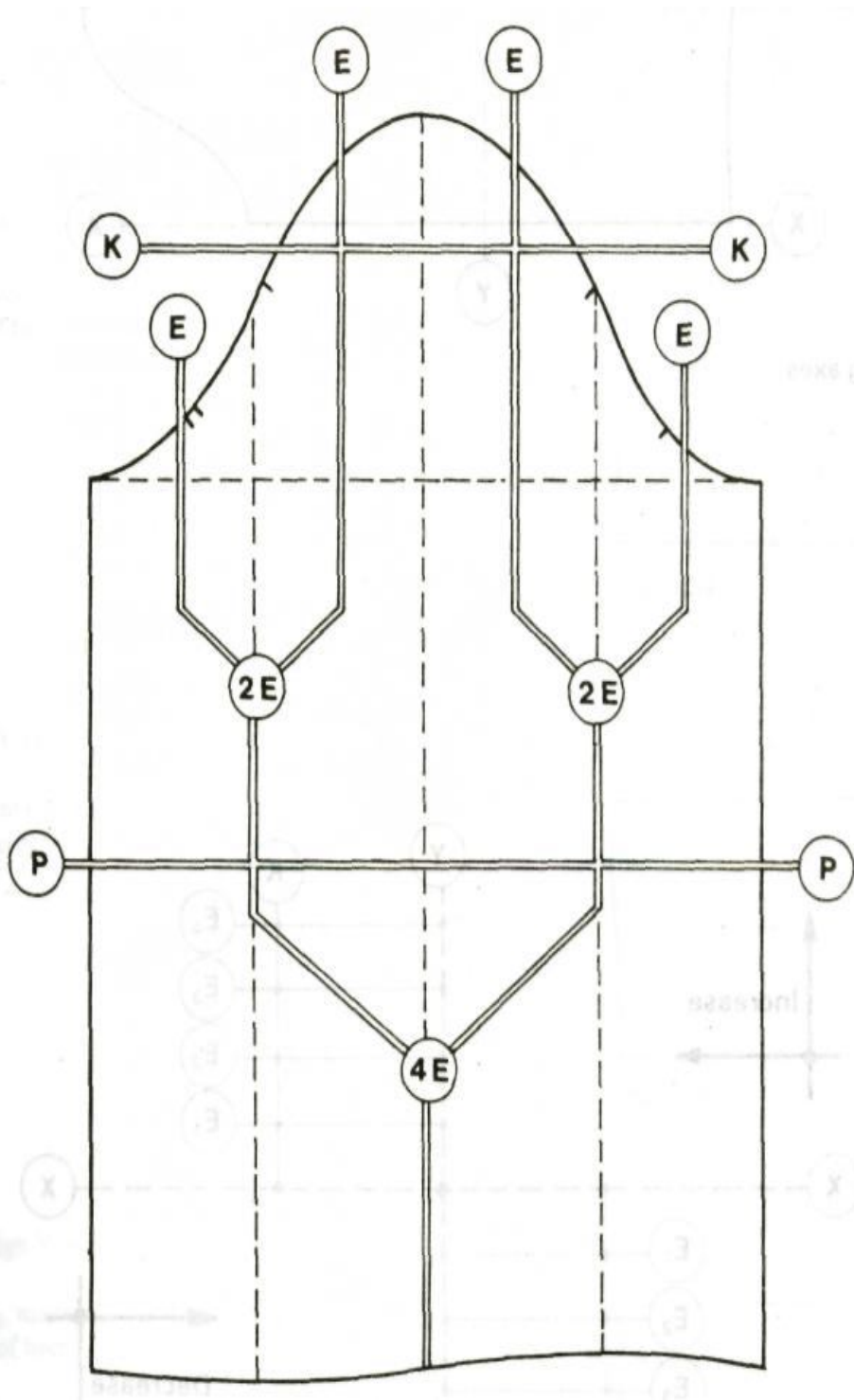
This grade is the key to all of the other sleeve grades demonstrated in this section, and as such should be I thoroughly understood.



Top and under sleeve relationships

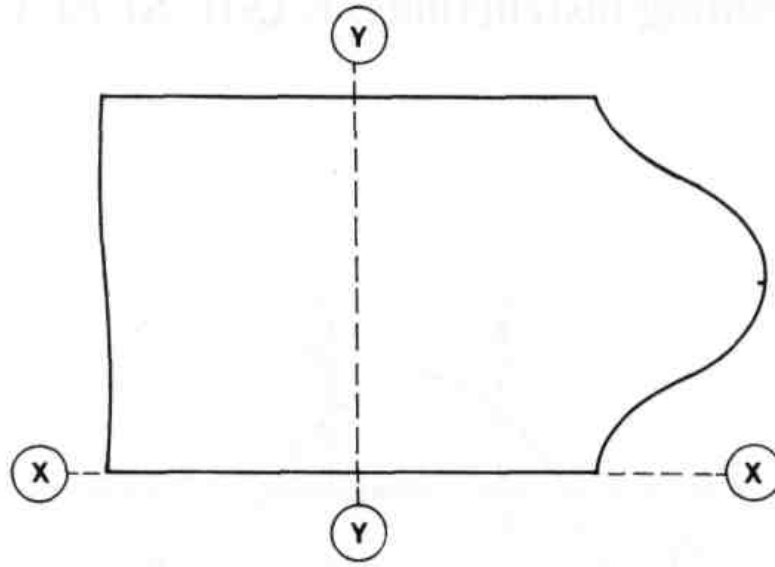
Fig.11.29

Grading Instructions: BASIC SLEEVE



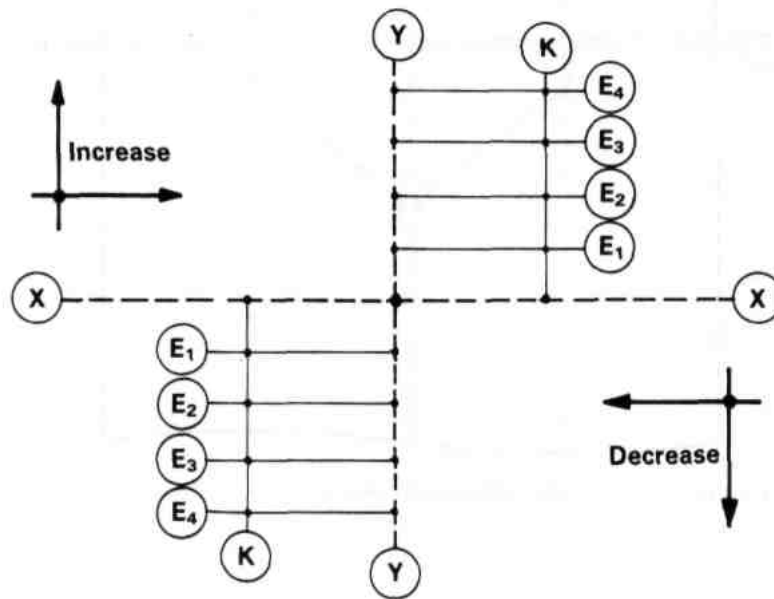
Grading increments for one-piece straight sleeve

Fig.11.30



Grading axes

11.31



Increment net

Fig.11.32

Stage 1: align pattern on X and Y axes (Fig. 11.33)

- Mark front seam
- Mark starts of sleeve head and hem line.

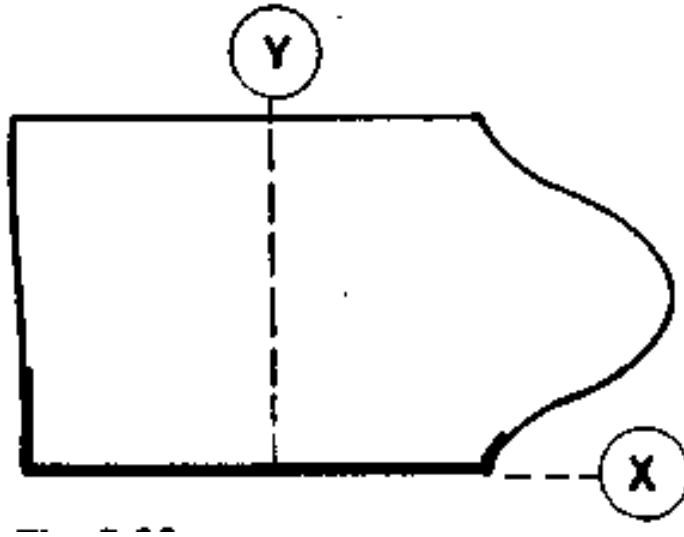


Fig.11.33

Stage2: remain on Y axis (Fig. 11.34)

- Move to E
- Mark front section of head
- Mark part of hem.

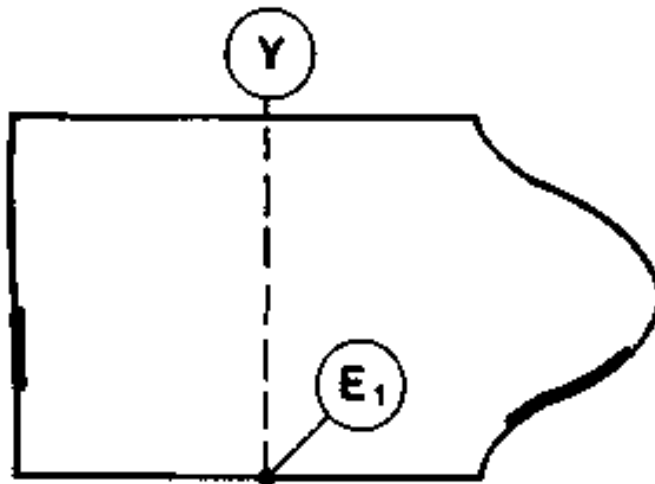


Fig.11.34

Stage 3: align Y axis of pattern on relevant K line (Fig.11.35)

- Move to E_2 mark head section and centre nip
- Mark hem to centre.

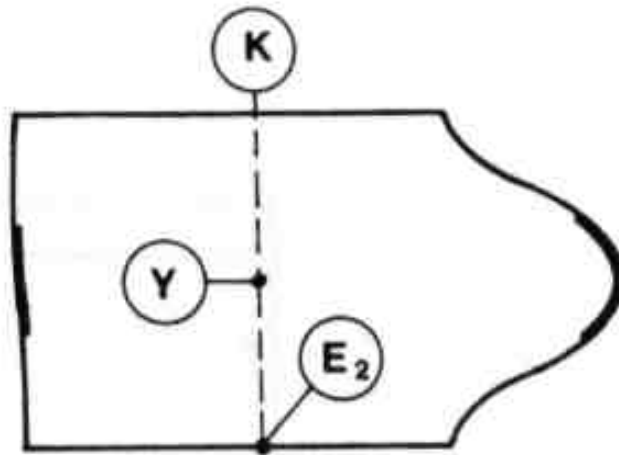


Fig.11.35

Stage 4: re-align Y axes of pattern and paper (Fig. 11.36)

- Move to E_3 , mark back section of head
- Mark part of hem.

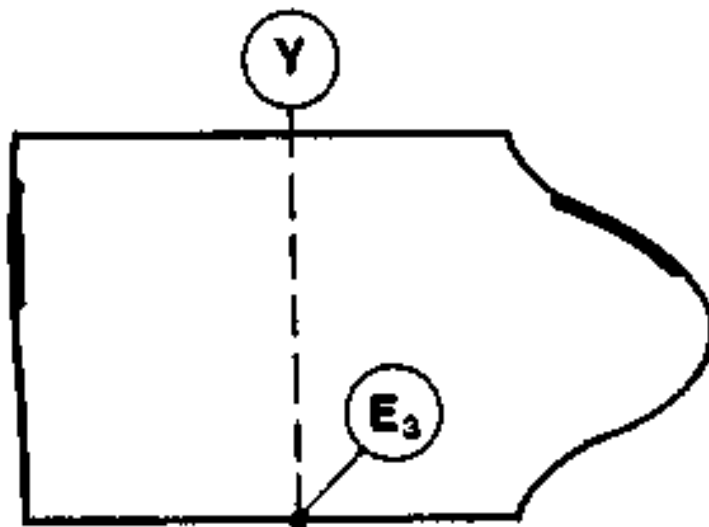


Fig.11.36

Stage 5: remain on Y axis (Fig. 11.37)

- Move to E_4
- Complete back section
- Mark back seam
- Complete hem.

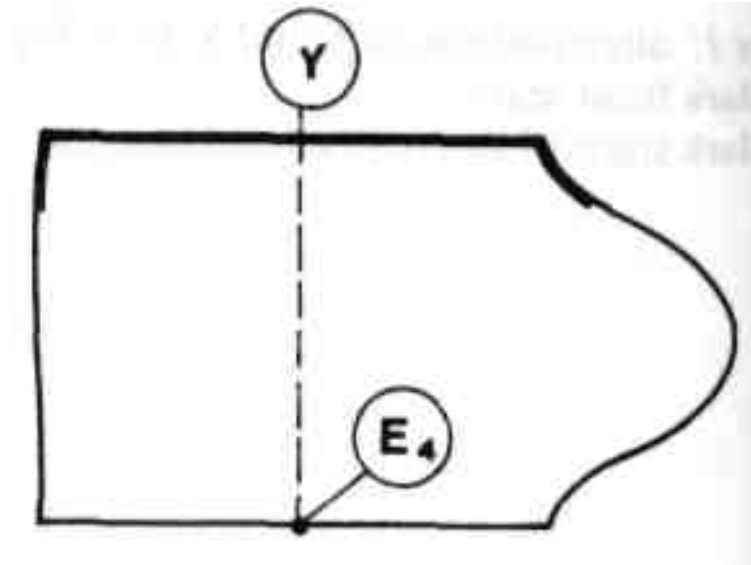


Fig.11.37

Stage 6: Use the pattern to (Fig.11.38)

- Blend head to front section
- Blend head to back section.

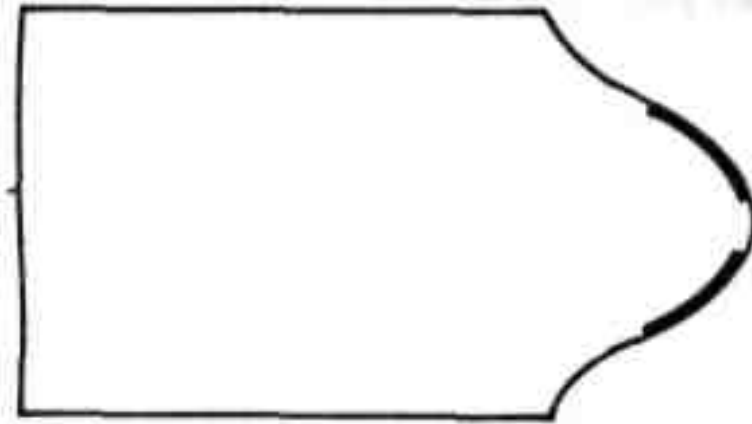
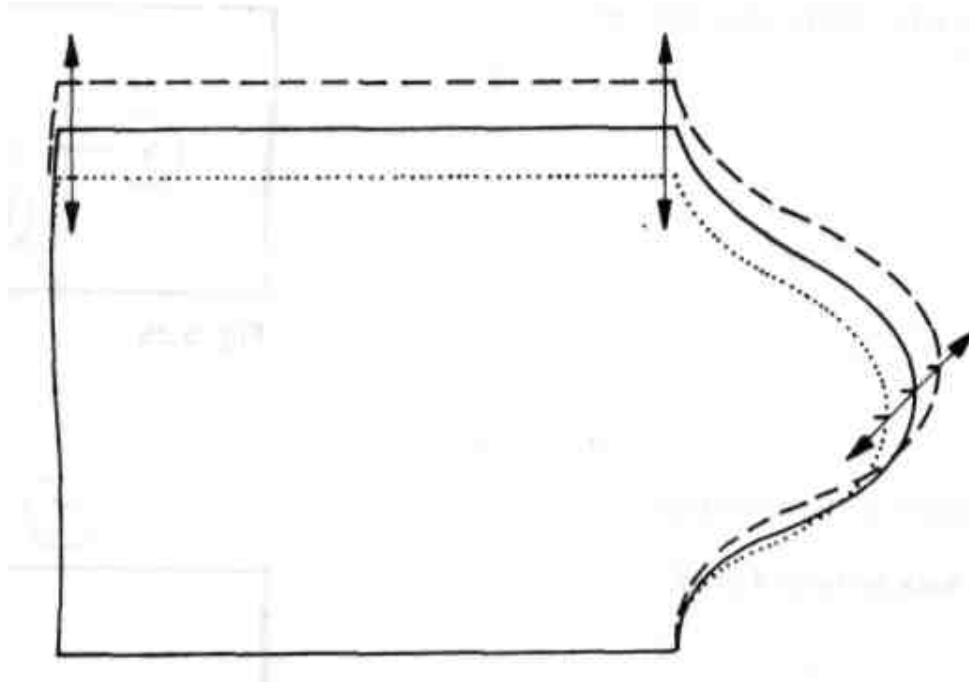


Fig.11.38



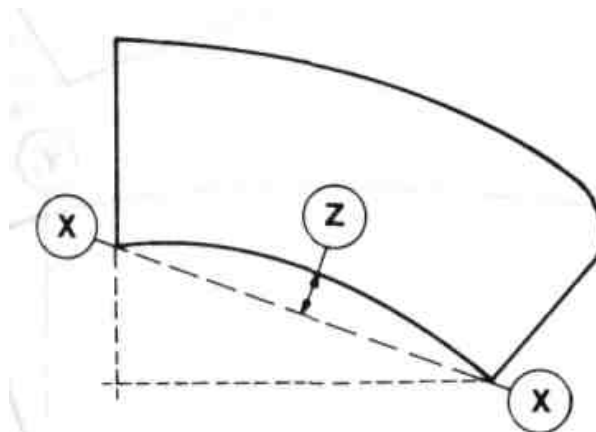
Grade of Basic Sleeve

11.2.4. THE BASIC COLLAR

The grading increments for this component are derived directly from the back and front neck base sections of the body and they are applied to the collar length as follows:

- Increment F: for the front neck length
- Increment F: for the back neck length

Thus for each size, the length of the basic collar changes by the amount of $2F$.

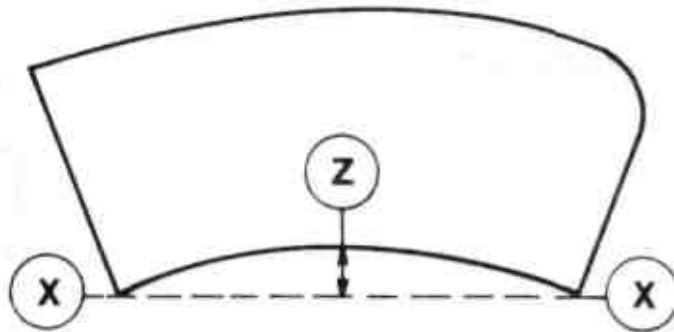


A. Collar construction (Distance Z)

Fig.11.39

The X axis for this grade comes from the construction systems generally used for this type of collar and this method ensures that the neck seam curvature remains unchanged

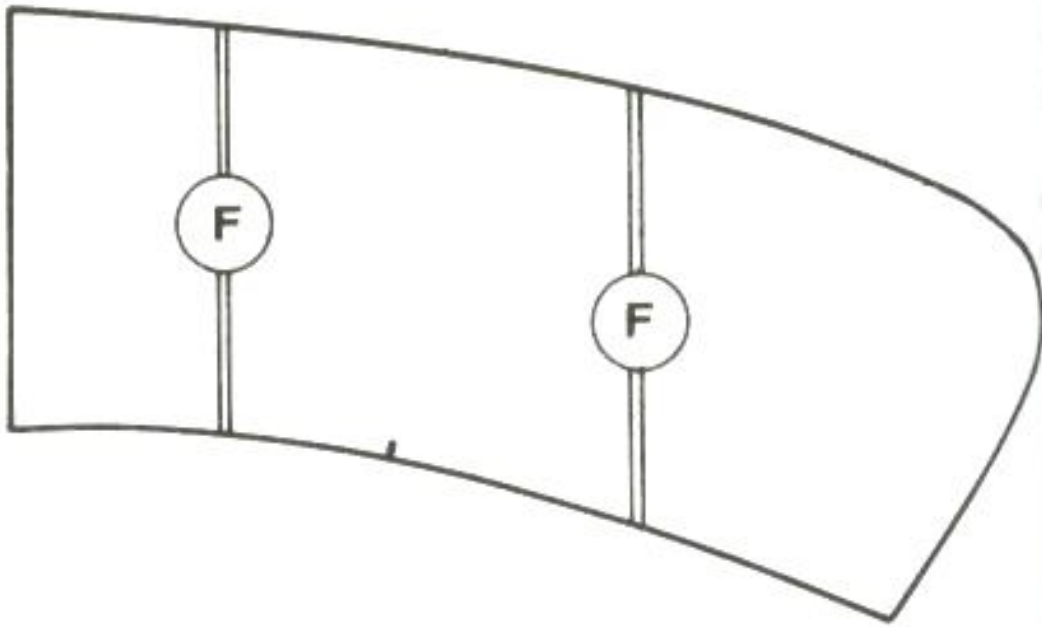
throughout the grading. This is an important principle because the distance Z (Fig.11.39) controls the stand and fall of the collar.



B. Grading axis (Distance Z)

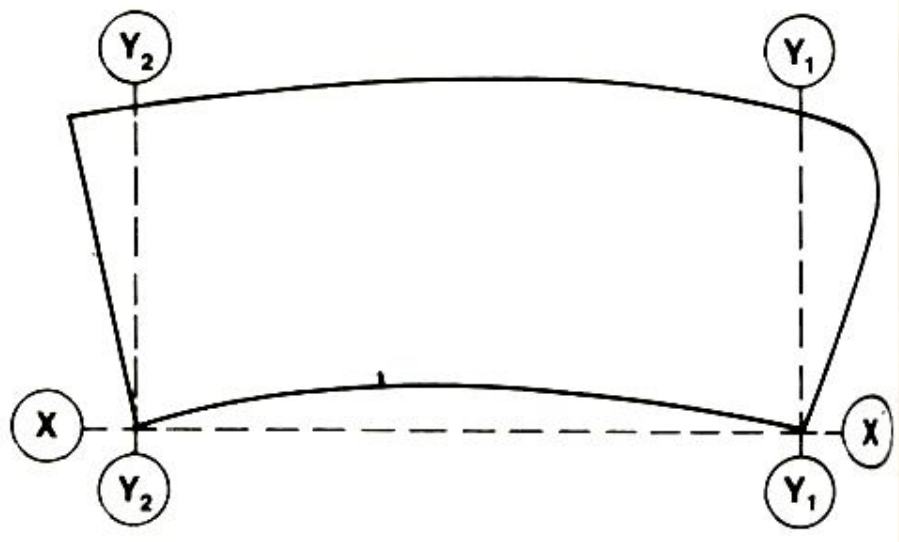
Fig.11.39

GRADING INSTRUCTIONS: THE BASIC COLLAR

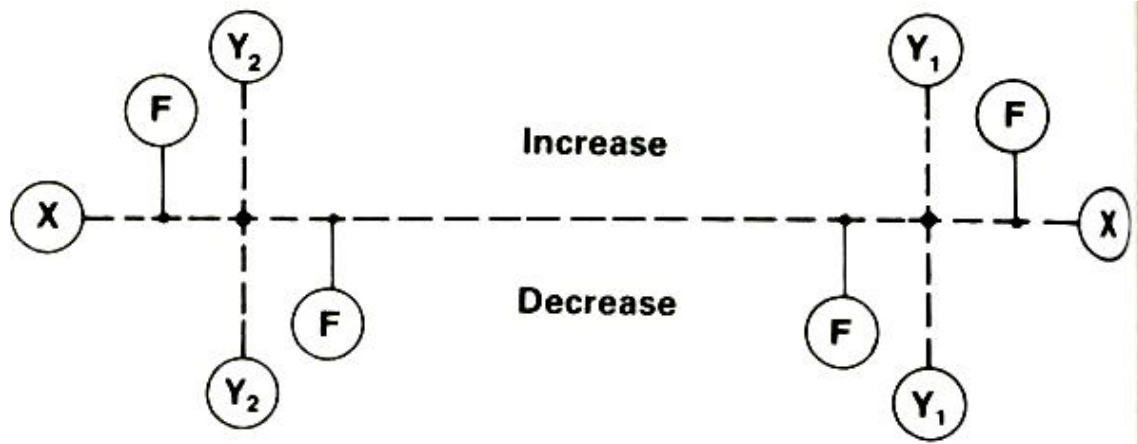


Grading increments for basic collar

Fig.11.40



Grading axes
Fig.11.41



Increment net
Fig.11.42

Stage 1: align pattern to (Fig.11.43)

- Xaxis
- Y_1 and Y_2 (upper or lower)
- Mark centre sections of neck seam and outside edge
- Mark shoulder seam nip

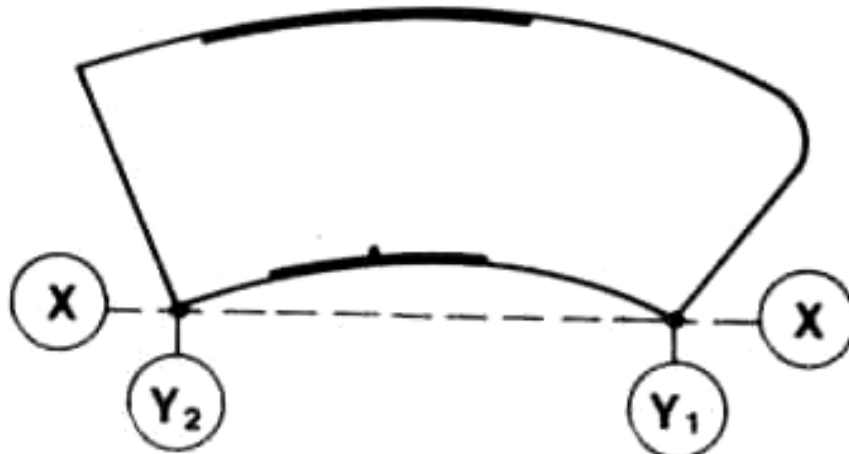


Fig.11.43

Stage2: remain on X axis (Fig. 11.44)

- Move centre back to F
- Mark centre back, part of neck seam and outside edge.

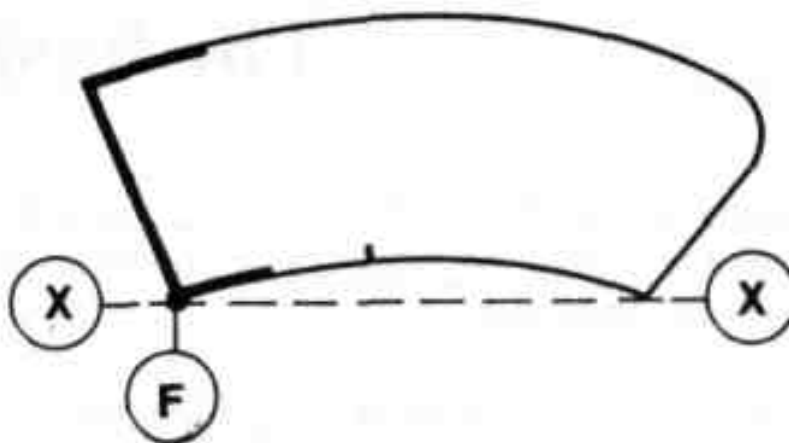


Fig.11.44

Stage3: remain on X axis (Fig. 11.45)

- Move collar front to F
- Mark front, part of neck seam and edge.

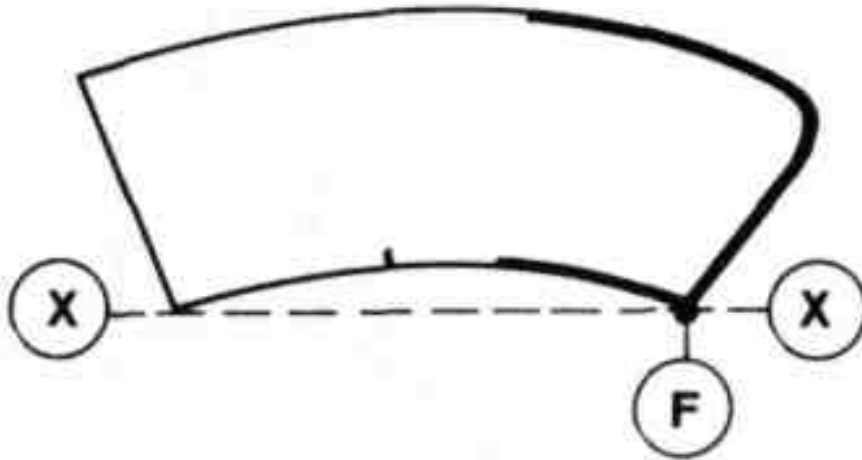


Fig.11.45

Stage 4: Use pattern to blend the neck seam and outside edge (Fig.11.46)

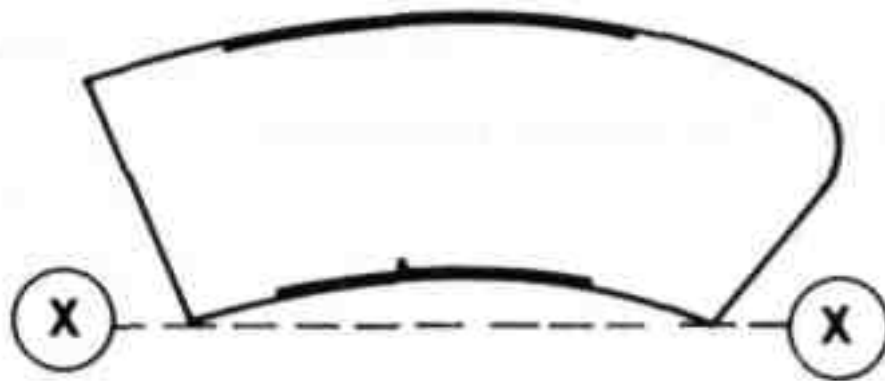
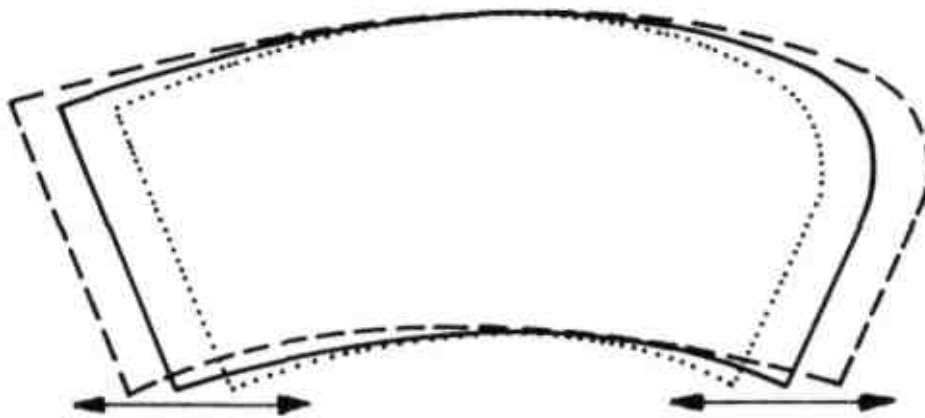


Fig.11.46



Grade of basic collar

11.3. LET US SUM UP

In this unit, we

- Discussed the Master grading for basic front, back, sleeve and collar.

11.4. LESSON END ACTIVITIES

- The distance students can have a practical experience by carrying out trails in master pattern grades.

11.5. POINTS FOR DISCUSSION

- Evaluate the master grading techniques by grading a particular garment style for different sizes.

11.6. REFERENCES

- Pattern Grading for Women's Clothes – The technology of sizing, Gerry Cooklin, Black Well science Ltd, London, 2004.

LESSON - 12

CONTENTS

- 12.0. Aims and Objectives
- 12.1. Definition
- 12.2. Rules in layout
- 12.3. Methods of layout
- 12.4. Special layouts
- 12.5. Let us sum up
- 12.6. Lesson end activities
- 12.7. Points for discussion
- 12.8. References

12.0. AIMS AND OBJECTIVES

- In this unit we have discussed the rules for layout, types of layout and special layouts.

After reading this unit you should be able to

- Identify which layout is most suitable for cutting the fabric in a most economical manner where fabric wastage should be minimized.

12.1. DEFINITION

It is a method of placing the pattern on fabric in the most economical manner to minimize the length of fabric.

12.2. RULES IN LAYOUT

1. Press the fabric as well as the pattern pieces flat before laying the pattern on the fabric.
2. Use a large table or any hard flat surface for accommodating your work.
3. If an open layout is used, place the fabric right side up on the table. For all other layouts, fold the fabric right sides facing and wrong sides out.
4. Decide on the best way to fold your cloth. This will depend on the width of the cloth, width of your pattern pieces, the type of cloth and design of the garment (whether left and right halves are identical, whether many pieces have to be cut on fold etc.). The common methods of folding the cloth for laying out pattern pieces are shown under the heading methods of layout (See Fig.12.1).
5. Make a trial layout by keeping weights or two pins per pattern, to make sure that cloth will be sufficient. Rules 6 to 9 must be borne in mind while making the trial layout.

6. Straight grain lines on patterns must be kept parallel to the fabric selvedge. To ensure this, measure and adjust the pattern so that both ends of the straight grain line are the same distance from the selvedge (see the sleeve pattern in Fig.12.1g) and pin the pattern to the fabric along the grain line arrows.

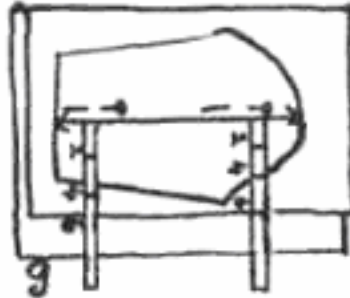


Fig.12.1g

7. Fold lines on the patterns must be kept on folded edges of fabric.

8. Leave enough space between patterns for cutting outward notches and marking seam allowances (if the patterns do not include seam allowances). Also make sure that there is enough material left for cutting out belts, facings, pockets, etc. for which you may not have made paper patterns.

9. The patterns must be placed on the fabric in the most economical way. Some hints on economical pattern placement are given below.

- (a) Try different layouts till you find one that requires minimum length of cloth. Start cutting only after all the pattern pieces are placed.
- (b) Wider end of large pieces should be placed at the cut edges (along one edge or both the edges).
- (c) Lay the pattern pieces close together.
- (d) Place as many pieces as possible near the selvedge ends so that the left-over material will be in one large bit rather than in two or more smaller bits. This will maximise the space available near the folded end for laying patterns that have to be kept on fold.
- (e) As far as possible try to fit the wide end of one piece beside the narrow end of another. (See the petticoat layout shown in Fig.12.1f)
- (f) Fit pieces similar in shape next to each other. This is called dovetailing (See Fig.12.1h).

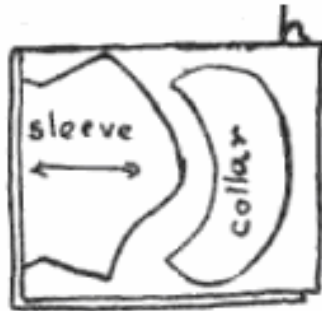


Fig.12.1h

- (g) If pattern pieces to be kept on fold are narrow, fold the material just wide enough to accommodate them (i.e. use off-centre lengthwise fold as in Fig.12.1b). This will leave all the excess material together on one side
- (h) Make duplicates for pattern pieces that have to be used twice and use them for making the trial layout.

10. Pin patterns to the fabric firmly. After placement of the patterns has been decided, pin the corners and the long outside edges of the patterns, placing pins close to and approximately perpendicular to the cutting line. Use just enough pins to keep the pattern in position. Too many pins will distort the edges. You should start cutting the fabric only after pinning all the pattern pieces.

11. Take care to use special layouts for asymmetric designs and for fabrics with designs, striped and checked designs, designs going in one direction and fabrics with nap and pile as discussed under the heading special layouts.

12.3. METHODS OF LAYOUT

a) Lengthwise centre fold (Fig.12.1a): Here the fabric is folded down the middle parallel to the selvages so that the selvages come together. This is the most frequently used fold. The layout for a simple frock on this type of fold is illustrated in the figure,

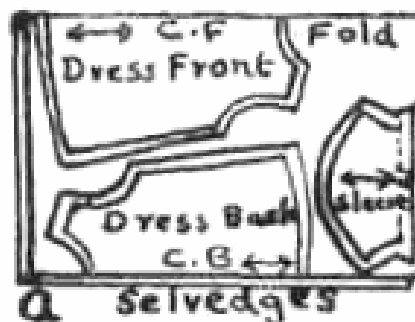


Fig.12.1a

b) Off centre lengthwise fold (Fig.12.1b): This is used when narrow pieces have to be cut on fold. To ensure that the fold is parallel to the selvedge, mark points measuring the

required distance (width of the half pattern including seam allowance) from the selvedge at regular intervals and fold along the markings. The layout for a child's panty on this type of layout is illustrated in the figure.

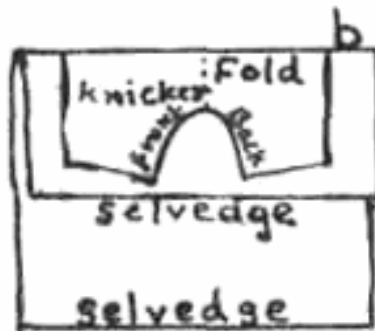


Fig.12.1b

c) Crosswise centre fold (Fig.12.1c): This is suitable for materials that are too narrow to accommodate the width of pattern pieces when folded lengthwise.

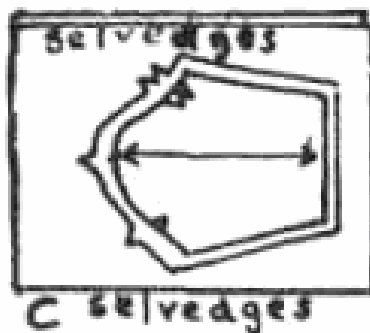


Fig.12.1c

d) Off centre crosswise fold (Fig.12.1d): When only a part of the material is required to cut pattern pieces that are too wide for lengthwise fold layout, this type of fold is used.

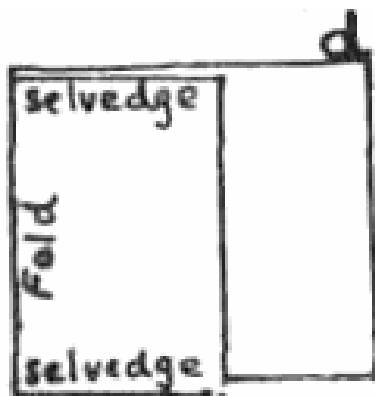


Fig.12.1d

e) **Double fold (Fig.12.1e):** This is used when many pattern pieces that are not too wide must be cut on fold. For garments with no opening for front and back sections, this type of fold can be used provided the cloth is wide enough to accommodate the patterns when folded this way.

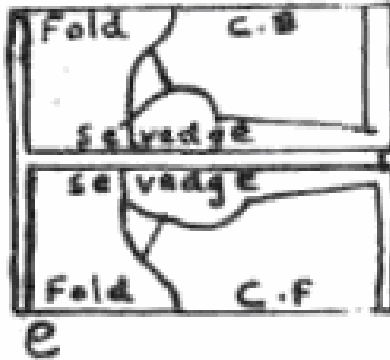


Fig.12.1e

f) **Combination fold (Fig.12.1f):** Here, lengthwise fold and crosswise fold are combined.

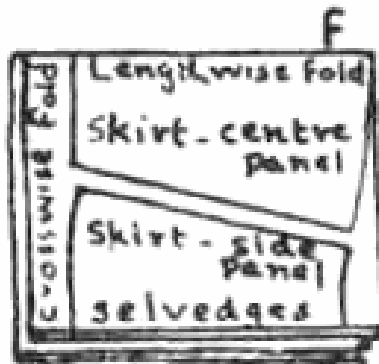
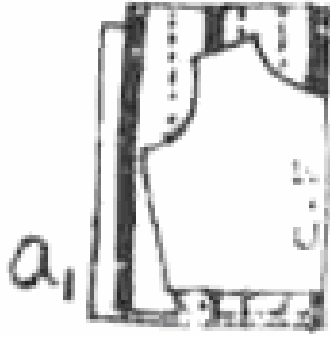


Fig.12.1f

g) **Open layout:** In this type of layout, the fabric is not folded at all. This is used especially for designs which require right and left halves to be cut separately

12.4. SPECIAL LAYOUTS

a) **Fabrics with lengthwise striped design (Fig.42a,a₁,b,b₁):** While cutting fabric with bold stripes, adjust the position of the pattern so that one of the prominent lines falls along the centre back of the garment and the remaining strips are identical on the two sides of the fold (See Fig.12.2a₁).

Fig.12.2a₁

Finished appearance of the garment is shown in Fig.12.2a.



Fig. 12.2a

Striped material can also be cut on the bias (See Fig.12.2b₁) forming a chevron design (in the shape of the letter V) at the centre front or the centre back seam or opening as shown in Fig.12.2b.

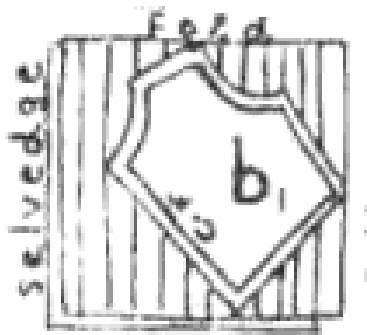
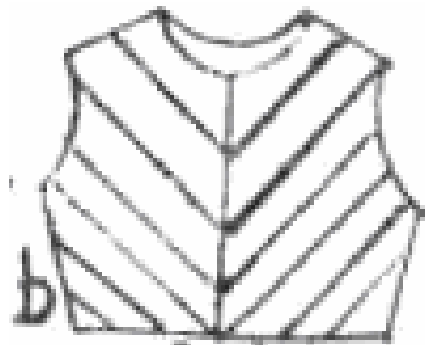
Fig.12.2b₁

Fig.12.2b

b) Fabrics with bold designs such as plaids, and crosswise stripes (Fig.12.2c,c₁): Match plaids and stripes so that they form continuous lines across seam openings (see Fig.12.2c) or meet at equal angles.

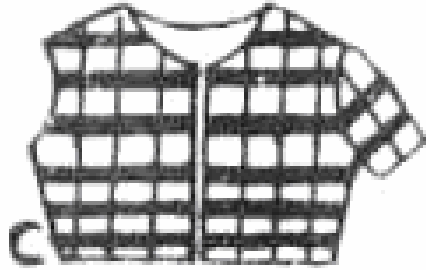
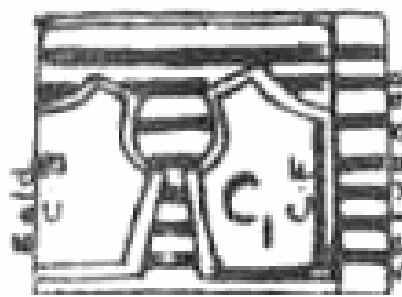


Fig.12.2c

When you fold such fabrics to keep the pattern pieces, make sure that the stripes are matching exactly on both layers of fabric, as in Fig.12.2c₁.

Fig.12.2c₁

If the print is large and spaced or with sweeping curves, drape the fabric on your body and look in the mirror to see where and how the highlighting part of the design should be placed.

c) Asymmetric designs (Fig.12.2d,d₁): These designs call for right and left sides to be cut separately from a single layer of fabric, taking care to see that you are not cutting both the sections for the same side. If the material has no right and wrong side, this problem will not arise. Fig.12.2d shows a blouse with asymmetric design.

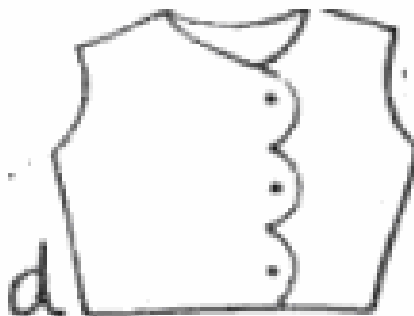
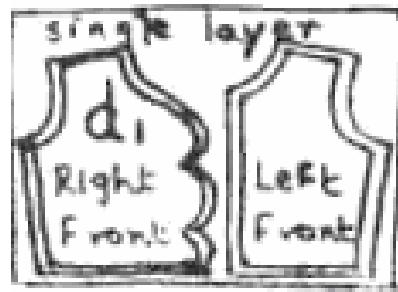
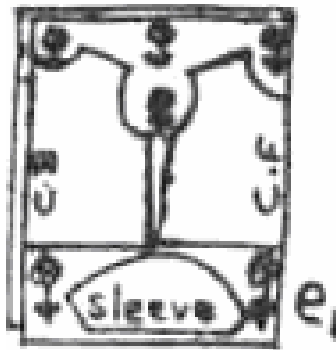


Fig.12.2d

Its layout is displayed in Fig.12.2d₁.

Fig.12.2d₁

d) Fabrics with one way design (Fig.12.2e,e₁): When cutting these fabrics, you must take care to see that all the pattern pieces are arranged in the same correct direction as shown in Fig.12.2e₁.

Fig.12.2e₁

The finished appearance will be like in Fig.12.2e. Otherwise the print will look upside down on sections which have been placed wrongly.



Fig.12.2e

e) Fabrics with nap and pile have to be treated like fabrics with one way design.

12.5. LET US SUM UP

In this unit, we

- Learnt the rules for pattern layout.
- Discussed the method of layout
- Discussed special layout

12.6. LESSON END ACTIVITIES

- The distance education students may try different trails of layout for different styles of different where the fabric consumption should be minimized.

12.7. POINTS FOR DISCUSSION

- Analyze suitable layout for a particular kind of garment style.

12.8. REFERENCES

- Practical clothing construction, Part I and II, Mary Mathews, Cosmic Press, Chennai (1986).

LESSON – 13: TRANSFERRING PATTERN MARKINGS AND FABRIC CUTTING

CONTENTS

- 13.0. Aims and Objectives
- 13.1. What can be done if cloth is insufficient
- 13.2. Fabric cutting
- 13.3. Transferring pattern markings
- 13.4. Stay stitching and case stitching
- 13.5. Let us sum up
- 13.6. Lesson end activities
- 13.7. Points for discussion
- 13.8. References

13.0. AIMS AND OBJECTIVES

- In this unit we have discussed how to transfer pattern markings onto the fabric and fabric cutting.

After reading this unit you should be able to

- Know, what can be done if cloth is insufficient.
- How to transfer pattern markings into fabric.
- Learned fabric cutting

13.1. WHAT CAN BE DONE IF CLOTH IS INSUFFICIENT

If cloth is not sufficient, the simplest thing to do is to buy extra fabric. But if it is not available, or you prefer to make do with what you have, the following procedures will help you.

(1) If possible, reduce seam allowances, hem allowances or length and width of some of the pattern pieces. Often you can do this without changing the fit of the garment by reducing fullness (gathers, pleats etc.).

(2) You may decide to cut some pieces on bias or crosswise grain. Some prints may look attractive if the yoke or sleeves are cut on bias or crosswise grain.

(3) Pattern pieces which have to be cut on fold can be cut near selvages and then joined up, with some trimming applied near the seam (eg., box pleat with a harmonising material, faggoting, lace etc) to make it look like an original pattern. You may even find that you end up with an interesting new design (necessity is the mother of invention!).

(4) Use some other material similar in colour and texture to cut parts that are not visible from outside.

(5) You may decide to modify the design of the garment. For example, if you were planning to have a puff sleeve, use a plain sleeve or omit the sleeve.

(6) Certain sections which ought to be cut in one piece may be cut out in more than one piece and then stitched together if material is otherwise not sufficient. This technique is called piecing. Piecing should be done inconspicuously with design and grain matched. Piecing in solid coloured fabrics is shown in Fig.13.1a and printed fabrics in Fig.13.1b.



Fig.13.1a,b

13.2. FABRIC CUTTING

(1) If the pattern does not have seam allowance, make sure, that you have drawn cutting lines on the fabric leaving enough seam allowance beyond the edge of the pattern before starting to cut the fabric.

(2) Hold the fabric flat on the cutting surface with your left hand, and cut with long even strokes using your right hand.

(3) Walk around the table as you cut because if you move the pattern and material, the grain may shift resulting in uneven edges.

(4) Cut accurately and smoothly exactly along the cutting lines.

(5). Notches should be cut wherever necessary (Fig.13.2). Notches are guides for joining the garment sections. They indicate which edges are seamed together. For example, the front part of the armhole and the front part of the sleeve are marked with two notches, while back part of the sleeve and the armhole are marked with one notch. A notch cut at centre of sleeve helps in matching sleeve centre to shoulder seam of bodice. Notches are usually cut outwards and not into the seam allowance especially if the fabric frays readily or if seam allowance is narrow.

Fig.13.2b shows a sleeve with a single notch (P) cut outwards to a sharp point and a double notch (K) cut outwards with a straight line spanning the width of two notches.



Fig 13.2b

This method of cutting a group of notches as one spanning the width of the notches saves time and effort. Notches may be cut inward as shown in Fig.13.2a, if the fabric is firmly woven and the seam allowance is not too narrow.

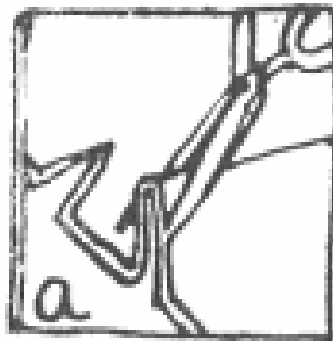


Fig.44a

Some prefer to make a short $\frac{1}{4}$ clip or slash to mark notches at beginning and termination points of seam lines, darts etc. on firm, nonravelling fabrics. On ravelling fabrics, some dress makers make a line of basting to mark important notches (Fig.13.2c).



Fig.13.2c

13.3. TRANSFERRING PATTERN MARKINGS

After cutting all the pattern pieces accurately you should transfer seam lines and all the pattern markings to the fabric (top layer as well as lower layer).

The common methods employed for marking fabrics are: use of tracing wheel and carbon paper contrasting coloured tailor's chalk, colour pencil and ordinary lead pencil (provided the colour of the fabric is such that the pencil marks will be visible on it), use of pins in combination with pencil or tailor's chalk, use of tailor's tacks etc. Each of these methods has its advantages and disadvantages as can be seen from the detailed explanations given below.

Tracing wheel and carbon paper (Fig.13.3a): This method is not suitable for delicate fabrics which may get spoilt by the sharp teeth of the tracing wheel. Another drawback is that carbon marks (and often smudges too) will be left on cloth and may be visible from the right side, especially if the fabric is transparent or if the carbon paper is of bad quality.



Fig.13.3a

In applying this method, you may use pencil (instead of tracing wheel) with carbon paper, but then you should trace only the ends (and a few points in between) of darts and seams.

If the pattern includes seam allowance and has no slashes or holes provided for facilitating transfer of pattern markings, proceed as follows. For patterns without allowance, follow the procedure explained under Tailor's chalk.

Fold the carbon paper in the middle with the wax sides (sides with carbon) facing. Remove a few pins from a portion of the pattern and slip the folded carbon paper with one side between the lower layer of fabric and the table and the other side between the pattern and the upper layer of fabric. (Be sure to check beforehand that the folded fabric has its right sides facing, and don't make the mistake of inserting carbon between the two layers of fabric). Now the wax sides of the carbon will be facing the wrong sides of the fabric. In Fig.13.3a pattern is labelled as 1, the upper layer of fabric as 2, and the under layer of fabric as 3. Pin the pattern in position again and run the tracing wheel along the seam lines and dart lines of the pattern as shown in the figure. For tracing straight lines, keep ruler

beside the line and run the tracing wheel along it. To avoid spoiling the fabric with carbon marks you may mark just the ends of seam lines, dart lines etc. If you have forgotten to cut notches which should have been cut outwards, mark the position of the notches by a stroke of the tracing wheel perpendicular to the seam line through the centre of the notch.)

Tailor's Chalk: If you have cut slashes or holes or inward notches in the pattern for beginning and termination points of darts and seams (or if you have not left seam allowance in the pattern), you can mark directly on to the top layer of fabric with tailor's chalk or ordinary pencil. Marks on the top layer can be transferred to the under layer of fabric by placing a carbon paper under it with wax face up, and using a tracing wheel; it can also be done with the help of pins as explained below

Common pins (Fig.13.3b): Markings on the top layer of fabric can be transferred to the lower layer by inserting pins through both layers of fabric at the points to be marked. As soon as one pin is inserted, turn the fabric and mark the pin point on the underside with chalk or pencil marks. After completing all the markings necessary remove the pattern and connect the chalk or pencil marks. (Use a ruler for straight lines). If the pattern has seam allowance and no holes or slashes near darts and seam lines, pins can be inserted through the pattern and double layer of fabric and the pattern lifted to mark the pin points on upper layer of fabrics.



Fig.13.3b

Tailor's tacks (Fig.13.3c,c₁,d): This method is especially good for silks and sheer fabrics. Unlike the other two methods it has the advantage that no pencil or carbon marks will be left on the fabric. The tacks should be worked using double thread of a contrasting colour so that they can be easily seen.

Working of continuous tailor's tacking (Fig.13.3c,c₁): If the pattern includes seam allowance and it has no slashes or holes provided for facilitating transfer of pattern markings, tailor's tacking is done as follows (See Fig.13.3c).

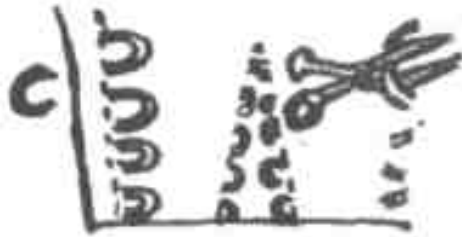


Fig.13.3c

Tack through the pattern and double layer of fabric along the seam lines and dart markings using uneven stitches of $\frac{1}{2}$ " length on 1 upper side and $\frac{1}{4}$ " length on under side. While making the stitches on the upper side do not pull them tight, instead leave them as loops of $\frac{1}{4}$ " height.

After completing the tacking, cut each loop along the midpoint as shown (Fig.13.3c). Unpin the pattern from the fabric and remove it carefully, making sure that the threads do not get pulled out of the fabric. Now raise the upper layer of fabric slightly and clip the threads between it and the bottom layer, so that thread tufts will be remaining on both layers of fabric (Fig.13.3c₁).

Fig.13.3c₁

Note: If the pattern has no seam allowance, tailor's tacking will be done through double layer of fabric just along the edge of the pattern without catching the pattern

Working of single tailor's tacks (Fig.13.3d): If you have provided holes or slashes at ends of seam lines, darts etc., you can work this type of tacking stitch. Fig.13.3d shows a dart with three holes cut in it (two holes at the base of the dart and one hole at the tip of the dart) to facilitate transfer of pattern markings. Through each of these holes, single tailor's tacking has been worked as follows. At the point to be marked, take a small stitch through the slash in the pattern, catching the double thickness of fabric and leaving a thread end of V length on the upper side. Work a back stitch in the same place and leave a loop of $\frac{1}{2}$ " height. Clip the thread, leaving a $\frac{3}{4}$ " thread end. After completing the tailor's tacks, unpin the pattern from the fabric and remove it gently. Now lift the upper layer of fabric and clip the threads between it and the bottom layer.



Fig.13.3d

Removing the pattern

After the fabric is marked completely, remove the paper patterns carefully and put them safely back in a cover.

13.4. STAY STITCHING AND CASE STITCHING

Stay stitching is a row of regulation machine stitching (stitch of normal length) using matching thread, done on a single thickness of fabric between the cut edge and the seam line, about 1/16" from the latter. Stay stitching helps to preserve the lines and grain of the fabric as cut by the pattern. It prevents curved edges like neckline, armhole etc. and bias edges like side seams from stretching and going out of shape. Stay stitching is also used for reinforcement at curves and corners to be slashed later in construction.

For slippery fabrics and fabrics which pucker, tack a tissue paper behind the fabric and stitch through the fabric and tissue paper. Stay stitching should be done with the grain. In Fig.13.4b the direction for stay stitching on a blouse front is indicated by small arrow heads drawn near the seam lines.



Fig.13.4b

EASE STITCHING

Ease stitching is done instead of stay stitching where a little extra fullness is needed as in a sleeve cap. For ease stitching you may use a standard size stitch with loose upper tension or a slightly longer stitch than normal stitch. Some times if the neckline is loose, ease stitching is done around it so that thread can be pulled to form small gathers, thus shortening the neckline. Always the under thread should be pulled for gathering and for this reason the bobbin thread should be strong. Also the upper tension should be looser than the under tension.

Note: On firmly woven fabrics, you need not do stay stitching on most seams. However, stay stitching must be done on neckline as soon as the garment is cut out. If you do not do this, you will have a lot of trouble adjusting the collar to fit the neckline or you may end up with a loose gaping neckline.

Advantages

1. Material will not go waste, since we can design according to the material.
2. Once it is draped it is easy to cut.
3. Correct exact fitting is possible.
4. No measurements should not taken often, for a particular person.

13.5. LET US SUM UP

In this unit, we

- Discussed the method to transfer pattern markings onto the fabric.
- Learnt what is stay and ease stitching.

13.6. LESSON END ACTIVITIES

- The distance education students may try different trails to transfer pattern markings onto the fabric, what can be done if fabric is insufficient.

13.7. POINTS FOR DISCUSSION

- Analyze the methods of transferring pattern marking.

13.8. REFERENCES

- Practical clothing construction, Part I and II, Mary Mathews, Cosmic Press, Chennai (1986).