



WIND ENERGY - THE FACTS

PART I

# TECHNOLOGY



**Acknowledgements**

Part I was compiled by Paul Gardner, Andrew Garrad, Lars Falbe Hansen, Peter Jamieson, Colin Morgan, Fatma Murray and Andrew Tindal of Garrad Hassan and Partners, UK; José Ignacio Cruz and Luis Arribas of CIEMAT, Spain; Nicholas Fichaux of the European Wind Energy Association (EWEA).

We would like to thank all the peer reviewers for their valuable advice and for the tremendous effort that they put into the revision of Part I.

Part I was carefully reviewed by the following experts:

- Nicolas Fichaux                      European Wind Energy Association
- Henning Kruse                        Siemens

- Takis Chaviaropoulos              CRES
- Angeles Santamaria Martin      Iberdrola
- Erik Lundtang Petersen            Risø DTU National Laboratory
- Jos Beurskens                        ECN
- Josep Prats                            Ecotècnia
- Eize de Vries                         Planet
- Flemming Rasmussen              Risø DTU National Laboratory
- Simon Watson                        Loughborough University
- Félix Avia                              CENER
- Murat Durak                         Turkish Wind Energy Association
- Jørgen Højstrup                    Suzlon Energy A/S



## I.1 INTRODUCTION

Electricity can be generated in many ways. In each case, a fuel is used to turn a turbine, which drives a generator, which feeds the grid. The turbines are designed to suit the particular fuel characteristics. The same applies to wind-generated electricity: the wind is the fuel, which drives the turbine, which generates electricity. But unlike fossil fuels, it is free and clean.

The politics and economics of wind energy have played an important role in the development of the industry and contributed to its present success, but the engineering is still pivotal. As the wind industry has become better established, the central place of engineering has become overshadowed by other issues, but this is a tribute to the success of engineers and their turbines. Part I of this volume addresses the key engineering issues:

- the wind – its characteristics and reliability; how it can be measured, quantified and harnessed;
- the turbines – their past achievements and future challenges, covering a range of sizes larger than most other technologies, from 50 W to 5 MW and beyond;
- the wind farms – the assembly of individual turbines into wind power stations or wind farms; their optimisation and development; and
- going offshore – the promise of a very large resource, but with major new technical challenges.

Part I provides a historical overview of turbine development, describes the present status and considers future challenges. This is a remarkable story, which started in the 19th century and accelerated over the last two decades of the 20th, on a course very similar to the early days of aeronautics. The story is far from finished, but it has certainly started with a vengeance.

Wind must be treated with great respect. The wind speed on a site has a very powerful effect on the economics of a wind farm, and wind provides both the fuel to generate electricity and, potentially, loads that can

destroy the turbines. This part describes how it can be quantified, harnessed and put to work in an economic and predictable manner. The long- and short-term behaviour of the wind is described. The latter can be successfully forecasted to allow wind energy to participate in electricity markets.

The enormous offshore wind resource offers great potential, but there are major engineering challenges, especially regarding reliability, installation and access.

In short, Part I explores how this new, vibrant and rapidly expanding industry exploits one of nature's most copious sources of energy – the wind.





## I.2 WIND RESOURCE ESTIMATION

### Introduction

The wind is the fuel for the wind power station. Small changes in wind speed produce greater changes in the commercial value of a wind farm. For example, a 1 per cent increase in the wind speed might be expected to yield a 2 per cent increase in energy production.

This chapter explains why knowledge of the wind is important for each and every stage of the development of a wind farm, from initial site selection to operation.

Europe has an enormous wind resource, which can be considered on various levels. At the top level, the potential resource can be examined from a strategic standpoint:

- Where is it?
- How does it compare to the EU and national electricity demands?
- What regions and areas offer good potential?

At the next level, it is necessary to understand the actual wind resource on a site in great detail:

- How is it measured?
- How will it change with time?
- How does it vary over the site?
- How is it harnessed?

It is at this stage that commercial evaluation of a wind farm is required, and robust estimates must be provided to support investment and financing decisions. Once the wind speed on the site has been estimated, it is then vital to make an accurate and reliable estimate of the resulting energy production from a wind farm that might be built there. This requires wind farm modelling and detailed investigation of the environmental and ownership constraints.

As its contribution to electricity consumption increases, in the context of liberalised energy markets,

new questions are beginning to emerge, which are critically linked to the nature of the wind:

- How can wind energy be consolidated, traded and generally integrated into our conventional electricity systems?
- Will an ability to forecast wind farm output help this integration?

These questions, and more, are addressed in this chapter. The first section looks at the strategic 'raw' resource issues, and the following sections provide a detailed step-by-step evaluation of the assessment process. A worked example of a real wind farm is then provided and, finally, recommendations are made about the important matters that need to be tackled in the near future to help wind energy play its full part.

### Regional Wind Resources

Naturally, wind energy developers are very interested in the energy that can be extracted from the wind, and how this varies by location. Wind is ubiquitous, and in order to make the choice of potential project sites an affordable and manageable process, some indication of the relative size of the 'wind resource' across an area is very useful. The wind resource is usually expressed as a wind speed or energy density, and typically there will be a cut-off value below which the energy that can be extracted is insufficient to merit a wind farm development.

### ON-SITE MEASUREMENT

The best, most accurate indication of the wind resource at a site is through on-site measurement, using an anemometer and wind vane (described in detail later in this chapter). This is, however, a fairly costly and time-consuming process.

## COMPUTER MODELLING

On a broader scale, wind speeds can be modelled using computer programs which describe the effects on the wind of parameters such as elevation, topography and ground surface cover. These models must be primed with some values at a known location, and usually this role is fulfilled by local meteorological station measurements or other weather-related recorded data, or data extracted from numerical weather prediction models, such as those used by national weather services.

Typically, these wind-mapping programs will derive a graphical representation of mean wind speed (for a specified height) across an area. This may take the form of a 'wind atlas', which represents the wind speed over flat homogeneous terrain, and requires adjustments to provide a site-specific wind speed prediction to be made with due consideration of the local topography. In some areas, 'wind maps' may be available; these include the effects of the terrain and ground cover. Wind atlases and wind maps have been produced for a very wide range of scales, from the world level down to the local government region, and represent the best estimate of the wind resource across a large area. They do not substitute for anemometry measurements – rather they serve to focus investigations and indicate where on-site measurements would be merited.

As a further stage in investigations, theoretical wind turbines can be placed in a chosen spacing within a geographical model containing wind speed values as a gridded data set. This is usually computed in a geographical information system (GIS). Employing assumptions on the technology conversion efficiency to units of energy, it is possible to derive an energy estimate that corresponds to a defined area. This is typically expressed as Region X having a wind energy potential of Y units of energy per year.

## CONSTRAINTS

Most wind energy resource studies start with a top-level theoretical resource, which is progressively

reduced through consideration of so-called 'constraints'. These are considerations which tend to reduce the area that in reality will be available to the wind energy developer. For instance, they can be geographically delineated conservation areas, areas where the wind speed is not economically viable or areas of unsuitable terrain. Areas potentially available for development are sequentially removed from the area over which the energy resource is summed.

Different estimates of the potential energy resource can be calculated according to assumptions about the area that will be available for development. The resource without constraints is often called the 'theoretical' resource; consideration of technical constraints results in an estimation of a 'technical' resource; and consideration of planning, environmental and social issues results in the estimation of a so-called 'practical' resource. Such studies were common in the 1980s and 1990s, when wind energy penetration was relatively low, but have been overtaken somewhat by events, as penetrations of wind energy are now substantial in many European countries.

## Wind Atlases

### ONSHORE





Figure I.2.1 shows the onshore wind energy resource as computed on a broad scale for the European Wind Atlas. The map shows different wind speed regions. The wind speeds at a 50m height above ground level within the regions identified may be estimated for different topographic conditions using the table below the figure.

The wind speed above which commercial exploitation can take place varies according to the specific market conditions. While countries such as Scotland clearly have exceptional potential, with rising fuel prices and consequently increasing power prices, every European country has a substantial technically and economically exploitable wind resource.

Figure I.2.1: European Wind Atlas, onshore



Wind resources at 50 metres above ground level for five different topographic conditions

	Sheltered terrain		Open terrain		At a sea coast		Open sea		Hills and ridges	
	m/s	W/m <sup>2</sup>	m/s	W/m <sup>2</sup>	m/s	W/m <sup>2</sup>	m/s	W/m <sup>2</sup>	m/s	W/m <sup>2</sup>
	>6.0	>250	>7.5	>500	>8.5	>700	>9.0	>800	>11.5	>1800
	5.0–6.0	150–250	6.5–7.5	300–500	7.0–8.5	400–700	8.0–9.0	600–800	10.0–11.5	1200–1800
	4.5–5.0	100–150	5.5–6.5	200–300	6.0–7.0	250–400	7.0–8.0	400–600	8.5–10.0	700–1200
	3.5–4.5	50–100	4.5–5.5	100–200	5.0–6.0	150–250	5.5–7.0	200–400	7.0–8.5	400–700
	<3.5	<50	<4.5	<100	<5.0	<150	<5.5	<200	<7.0	<400

Source: Risø DTU (see Appendix A for colour version)

The European Wind Atlas employs meteorological data from a selection of monitoring stations, and shows the distribution of wind speeds on a broad scale. It has been used extensively by developers and governments in estimating the resource and regional variations. It is possible to map wind speeds at a higher resolution, using, for instance, more detailed topographical data and a larger sample size of meteorological data, in order to show more local variations in wind speed. This can be used by developers looking for sites in a particular country.

There are many examples of national, regional and local wind atlases, for Europe and the rest of the world, but they are far too numerous to list here. When investigating a particular region or country regarding its development potential, one of the first questions is always ‘Is there a wind atlas for this area?’.

A review of national wind atlases for European countries has been undertaken for this edition of *Wind Energy – The Facts*, the results of which are shown in Table I.2.1. Where obtained and permission granted, map reproductions are contained in Appendix A. The European Wind Atlas resulted in the development of a wind-mapping tool called WAsP, and this is used widely for both broad-scale wind mapping and more site-specific applications. Table I.2.1 distinguishes between the use of WAsP and ‘other’ wind mapping methods.

## OFFSHORE

Wind atlases for offshore are covered in Chapter I.5 (pages 107–124).

## Local Wind Resource Assessment and Energy Analysis

The previous section presented wind maps for Europe and considered the wind resource at a strategic level. The purpose of this section is to consider the resource

Table I.2.1: Wind atlases, Europe

Country	Coverage in the European Wind Atlas	Other WAsP application	Other model
<b>EU-27</b>			
Austria		✓ [1]	
Belgium	✓		
Bulgaria			✓ [14]
Cyprus			
Czech Republic		✓ [1]	
Denmark	✓	✓ [2]	✓ [3]
Estonia		✓ [15]	✓ [16, 17]
Finland		✓ [4]	
France	✓		
Germany	✓ [5]		
Greece	✓		✓ [6]
Hungary		✓ [1]	
Ireland	✓	✓ [7]	✓ [8]
Italy	✓		✓ [9, 10]
Latvia		✓ [15]	[18]
Lithuania		✓ [15]	
Luxembourg	✓		
Malta			
The Netherlands	✓		
Poland			✓ [19]
Portugal	✓		
Romania			✓ [20]
Slovakia		✓ [1]	
Slovenia		✓ [1]	
Spain	✓		
Sweden		✓ [11]	
UK	✓		✓ [12]
<b>Other countries</b>			
Turkey			✓ [21]
Armenia			✓ [22]
Croatia		✓ [1]	
Georgia		✓ [23]	
Norway			✓ [13]
Russia		✓ [24]	
Switzerland			✓ [25]

Sources: Mortensen et al. (2007); for sources 1–25, see the section at the end of References

assessment and modelling at a local, wind farm, level. To the wind farm developer, the regional wind maps are valuable tools for site finding, but are not accurate enough to justify the financing of the development. Here it will be shown that the single most important characteristic of a site is its wind speed, and that the performance of a wind farm is very sensitive to uncertainties and errors in the basic wind speed estimate.

For the majority of prospective wind farms, the developer must undertake a wind resource measurement and analysis programme. This must provide a robust prediction of the expected energy production over its lifetime. This section discusses the issues that are pertinent to recording an appropriate set of site wind data, and the methodologies that can be used to predict the expected long-term energy production of a project. It is noted that a prediction of the energy production of a wind farm is possible using methods such as the wind atlas methodology within WASP, using only off-site data from nearby meteorological stations. However, where the meteorological stations used have only data from low elevations, such as 10 m height, and/or the stations are located far from the site, such analyses are generally used only to assess the initial feasibility of wind farm sites. It is also possible to make predictions of the wind speed at a site using a numerical wind atlas methodology, based on a data source such as the 'reanalysis' numerical weather model data sets. Again, such data are usually used more for feasibility studies than final analyses. The text below describes an analysis where on-site wind speed and direction measurements from a relatively tall mast are available.

Figure I.2.2 provides an overview of the whole process. The sections below describe this process step by step. Appendix C provides a worked example of a real wind farm, for which these techniques were used to estimate long-term energy production forecast and compares this pre-construction production estimate with the actual production of the wind farm over the

first year of operation. It is noted that this example is from a wind farm constructed several years ago, so the turbines are relatively modest in size compared with typical current norms. Also, some elements of the analysis methods have altered a little – for example, a more detailed definition of the wind farm loss factor is now commonly used.

Figure I.2.2 represents a simplification of the process. In reality it will be necessary to also iterate the turbine selection and layout design process, based on environmental conditions such as turbine noise, compliance with electrical grid requirements, commercial considerations associated with contracting for the supply of the turbines and detailed turbine loading considerations.

### THE IMPORTANCE OF THE WIND RESOURCE

Wind energy has the attractive attribute that the fuel is free and that this will remain the case for the project lifetime and beyond. The economics of a project are thus crucially dependent on the site wind resource. At the start of the project development process, the long-term mean wind speed at the site is unknown. To illustrate the importance of the long-term mean wind speed, Table I.2.2 shows the energy production of a 10 MW project for a range of long-term annual mean wind speeds.

It can be seen that when the long-term mean wind speed is increased from 6 to 10 m/s, about 67 per cent, the energy production increases by 134 per cent. This range of speeds would be typical of Bavaria at the low end and hilltop locations in Scotland or Ireland at the high end. As the capital cost is not strongly dependent on wind speed, the sensitivity of the project economics to wind speed is clear. Table I.2.2 illustrates the importance of having as accurate a definition of the site wind resource as possible.

The sensitivity of energy yield to wind speed variation varies with the wind speed. For a low wind speed



Figure I.2.2: Overview of the energy prediction process

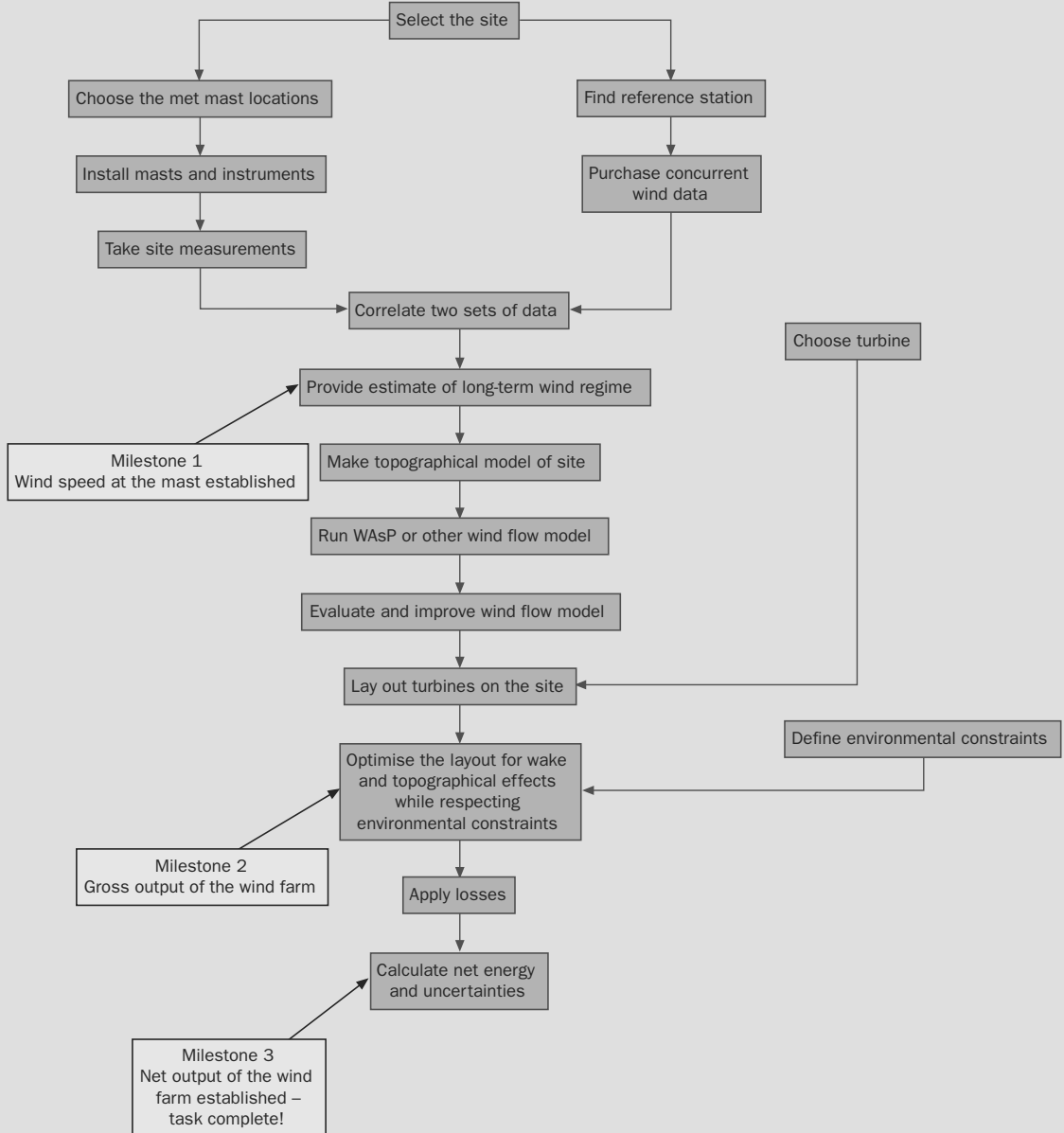

**Note:** For some sites, no suitable reference station is available. In such cases, only site data is used and longer on-site data sets are desirable.

Source: Garrad Hassan

Table I.2.2: Sensitivity of wind farm energy production to annual mean wind speed

Wind speed (m/s)	Wind speed normalised to 6 m/s (%)	Energy production of 10 MW wind farm (MWh/annum)*	Energy production normalised to 6 m/s site (%)	Capital cost normalised to 6 m/s site (%)
5	83	11,150	63	100
6	100	17,714	100	100
7	117	24,534	138	102
8	133	30,972	175	105
9	150	36,656	207	110
10	167	41,386	234	120

**Note:** \*Assumes typical turbine performance, air density of 1.225 kg/m<sup>3</sup>, total losses of 12 per cent and Rayleigh wind speed distribution.

Source: Garrad Hassan

site, the sensitivity is greater than for a high wind speed site. For example, at a low wind speed site, a 1 per cent change in wind speed might result in a 2 per cent change in energy, whereas for a high wind speed site the difference might be only 1.5 per cent. Table I.2.2 is in fact a simplification of the reality of the situation, where different specifications of turbine model would typically be selected for low and high wind speed sites, but it serves to illustrate the importance of wind speed to energy production.

The commercial value of a wind farm development is therefore crucially dependent on the energy yield, which in turn is highly sensitive to the wind speed. A change of wind speed of a few per cent thus makes an enormous difference in financial terms for both debt and equity.

In summary, the single most important characteristic of a wind farm site is the wind speed. Thus every effort should be made to maximise the length, quality and geographical coverage across the wind farm site of the data collected. However, measurement is undertaken at the very beginning of the project, and some compromise is therefore inevitable.

## BEST PRACTICE FOR ACCURATE WIND SPEED MEASUREMENTS

The results shown here illustrate the importance of having an accurate knowledge of the wind resource. A high-quality site wind speed measurement campaign is therefore of crucial importance in reducing the uncertainty in the predicted energy production of a proposed project. The goal for a wind measurement campaign is to provide information to allow the best possible estimate of the energy on the site to be provided. The question of how many masts to use and how tall they should be then arises.

### Number and Height of Meteorological Masts

For a small wind farm site, it is likely that one meteorological mast is sufficient to provide an accurate assessment of the wind resource at the site. For medium wind farms, say in excess of 20 MW, located in complex terrain, it is likely that more than one mast will be required to give an adequate definition of the wind resource across the site. For large projects of around 100 MW, located in complex terrain, it is particularly important to take great care in 'designing' a monitoring campaign to record the necessary data for a robust analysis in a cost-effective way.

In simple terrain, where there is already a lot of experience and close neighbouring wind farms, the performance of these wind farms can be used instead of a measurement campaign. North Germany and Denmark are obvious examples. A great many turbines have been sited in this way. However, great caution must be exercised in extending this approach to more complex areas.

The locations and specifications of the mast or masts need to be considered on a site-specific basis, but generally, if there are significant numbers of turbines more than 1 km from a meteorological mast in terrain that is either complex or in which there is significant forestry, it is likely that additional masts will be required.

In such circumstances, discussion with the analyst responsible for assessing the wind resource at the site is recommended at an early stage.

Turning now to the height of the masts, it is known that the wind speed generally increases with height, as illustrated in Figure I.2.3.

Figure I.2.3 schematically shows the way in which the wind speed grows. This characteristic is called 'shear' and the shape of this curve is known as the 'wind shear profile'. Given the discussion above about the importance of accurate wind speed measurements, it is clear that it will be important to measure the wind speed as near to the hub height of the proposed turbine as possible. If a hub height measurement is not made, then it will be necessary to estimate the shear profile. This can be done, but it creates uncertainties. Commercial wind turbines typically have hub heights in the 60–120 m range. The costs of meteorological masts increase with height. Tilt-up guyed masts may be used up to heights of 60 or 80 m. Beyond such heights, cranes are required to install masts, which increases costs. If 'best practice' of a hub height mast is not

followed, then a reasonable compromise is to ensure that masts are no less than 75 per cent of the hub height of the turbines.

### Specification of Monitoring Equipment and Required Signals

A typical anemometry mast will have a number of anemometers (devices to measure wind speed) installed at different heights on the mast, and one or two wind vanes (devices to measure wind direction). These will be connected to a data logger, at the base of a mast, via screened cables. It is unusual for there to be a power supply at a prospective wind farm site, so the whole anemometry system is usually battery operated. Some systems have battery charging via a solar panel or small wind turbine. For some systems, particularly in cold climates, the measurement of the temperature is important to assist with the detection of icing of the anemometers. In such circumstances, the use of heated or 'ice-free' anemometers is beneficial; however, their use without an external power source is usually impractical. Measurement of the pressure at the site is desirable but often not essential.

Remote sensing techniques are now being used to measure the wind speeds at wind farm sites. The technology available for this is being developed rapidly, and although the use of remote sensing devices on wind farms is not currently widespread, such devices are expected to become more widely used in the near future.

Remote sensing devices are essentially ground-based devices which can measure wind speeds at a range of heights without the need for a conventional mast. There are two main sorts of devices:

1. Sodar (SOund Detection And Ranging), which emits and receives sound and from this infers the wind speed at different heights using the doppler shift principle; and
2. Lidar (LIght Detection And Ranging), which also uses the doppler shift principle, but emits and receives light from a laser.

Figure I.2.3: The atmospheric boundary layer shear profile

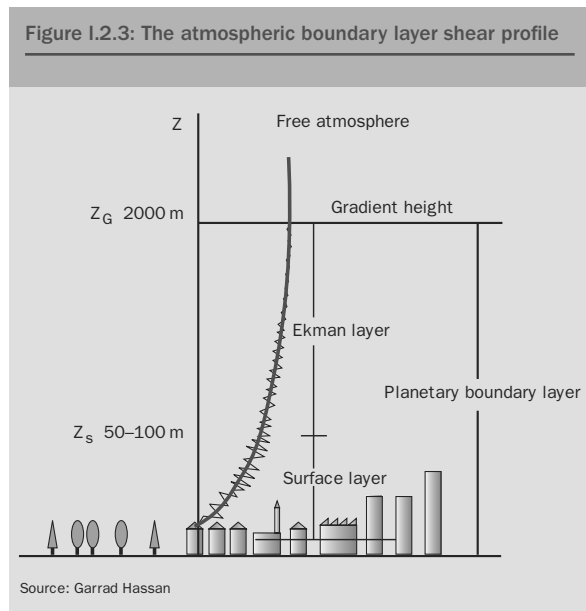

Sodar has been used for assessing wind farm sites for some years, particularly in the US and Germany. It is often used in combination with conventional anemometry and, historically, the results have been used to provide more information to better understand the patterns of the wind regime at a site, rather than necessarily using the data in a direct, quantitative way. Recently, some wind energy-specific Sodar products have come onto the market and experience is currently being gained from these new devices.

Lidar devices have made an entry into the wind market over the last one to two years, and two main commercial models are currently available. Published papers on the devices show they are capable of achieving impressive accuracy levels, and it is expected that their use in wind energy applications will increase.

The clear merit of remote sensing devices is that they do not need a mast. However, Lidar devices, in particular, are relatively expensive to purchase and both devices draw significantly more power than conventional anemometry, so for remote sites a local, off-grid power supply solution would be needed.

It is recommended that in-house or external experts are used to help make an informed decision about when and how to use remote sensing devices at potential wind farm sites.

Signals that would typically be recorded for each sensor, with a ten-minute averaging period, are as follows:

- mean wind speed;
- maximum three-second gust wind speed;
- true standard deviation of wind speed;
- mean wind direction;
- mean temperature; and
- logger battery voltage.

In recent years, it has become standard practice to download data remotely, via either modem or a satellite link. This approach has made managing large quantities of data from masts, on a range of prospective sites, significantly more efficient than manual downloading. It also has the potential to improve data coverage rates.

Recommendations provided by the International Electrotechnical Committee (IEC), the International Energy Agency (IEA) and the International Network for Harmonised and Recognised Wind Energy Measurement (MEASNET), provide substantial detail on minimum technical requirements for anemometers, wind vanes and data loggers. It is strongly recommended that anyone intending to make 'bankable' wind measurements should refer to these documents. Historically, a notable deviation from best practice, as defined in the IEC and IEA documents, is the use of anemometers that have not been individually calibrated for the assessment of the wind resource at the site. Each sensor will have a slightly different operational characteristic, as a result of variations in manufacturing tolerances. The use of individually calibrated anemometers has a direct impact on reducing the uncertainty in the predicted wind speed at a site and is therefore to be recommended.

Over the past decade, perhaps the most significant shortcoming of wind speed measurements at prospective wind farm sites has been the poor mounting arrangement of the sensors. There is an increasing body of measured data which has demonstrated that if the separation of anemometers from the meteorological mast, booms and other sensors is not sufficient, then the wind speed recorded by the sensor is not the true wind speed. Instead, it is a wind speed that is influenced by the presence of the other objects. The effect of the mast structure on the flow field around the mast top is illustrated in Figure I.2.4. The figure shows that there is a complicated flow pattern, which must be accommodated when mounting the anemometry.

These results have been predicted using a commercial computational fluid dynamics (CFD) code. It is important to be aware of the potential influence of the support structure on the measured data. Detailed guidance is provided in the International Energy Agency's Annex XI (1999), on specific separation distances which are required to reduce the influence of the support structure on the measurement to

Figure I.2.4: Predicted wind speed distribution around and above a meteorological mast using CFD

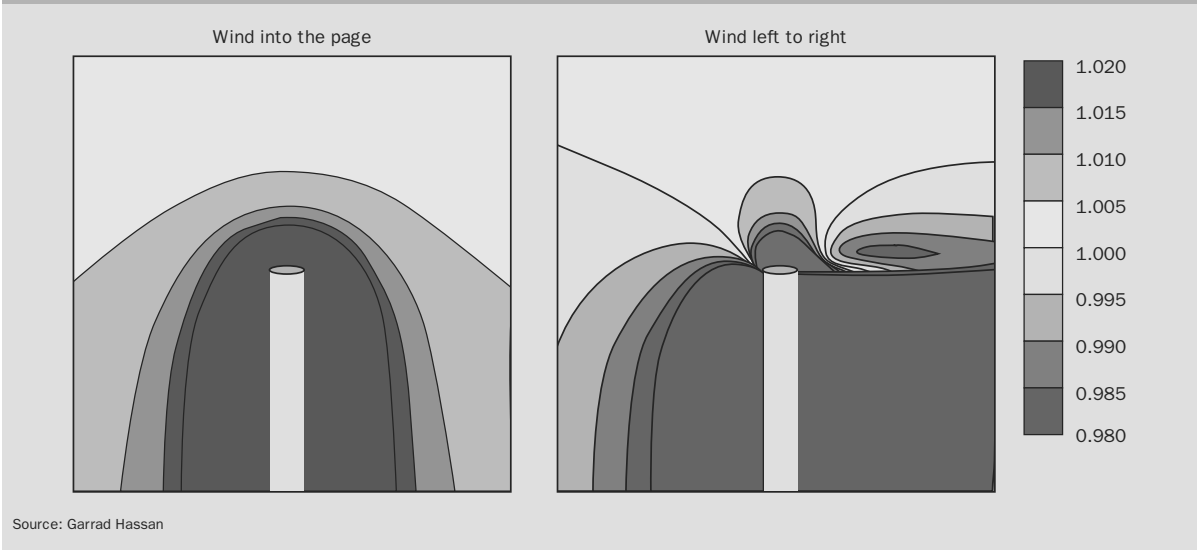

acceptable levels. Illustrative examples that demonstrate good and poor mounting arrangements are presented in Figure I.2.5.

If the guidance presented above is followed, a high-quality set of wind data should become available, in time, from a prospective site. The absolute minimum

requirement is for data to cover one year, so that any seasonal variation can be properly captured. In addition to specifying and installing appropriate equipment, vigilance is required in the regular downloading and checking of data, to ensure that high levels of data coverage are achieved. It will be necessary to demonstrate, either internally or externally, the provenance of the data on which important financial decisions are being made. Therefore it is important to maintain accurate records regarding all aspects of the specification, calibration, installation and maintenance of the equipment used.

Figure I.2.5: Summary of good practice (left) and poor practice (right) mounting arrangements (arrow indicates dominant wind direction)

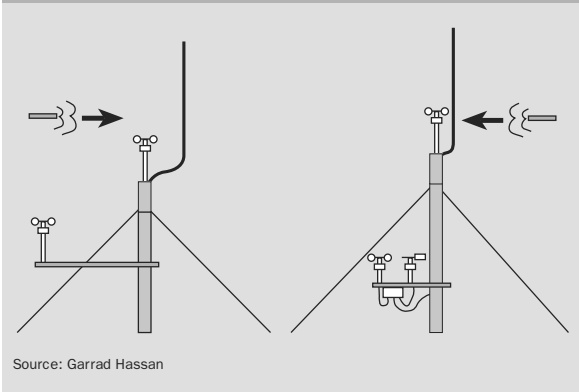

### THE ANNUAL VARIABILITY OF WIND SPEED

A 'wind rose' is the term given to the way in which the joint wind speed and direction distribution is defined. An example is given in Figure I.2.6. The wind rose can be thought of as a wheel with spokes, spaced, in this example, at 30 degrees. For each sector, the wind is considered separately. The duration for which the wind comes from this sector is shown by the length of the

Figure I.2.6: Wind rose

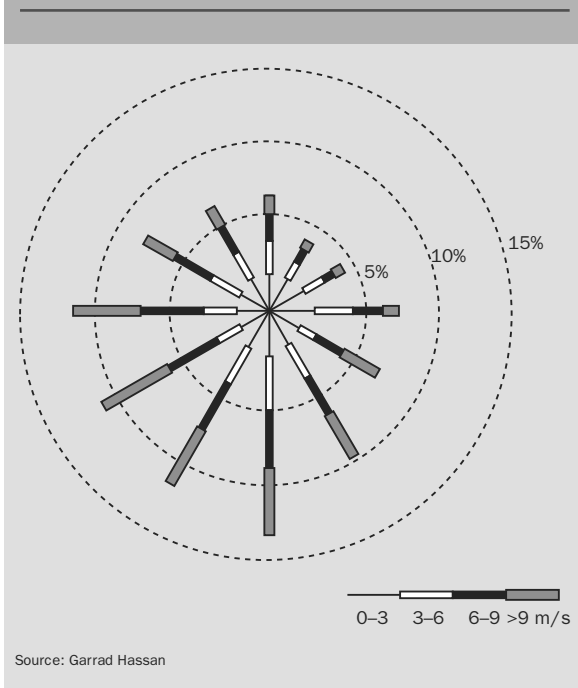

spoke and the speed is shown by the thickness of the spoke. The design of a wind farm is sensitive to the shape of the wind rose for the site. In some areas, particularly in areas where the wind is driven by thermal effects, the wind can be very unidirectional. For example, in Palm Springs in the US, the wind comes from a sector 10 degrees wide for 95 per cent of the year. In this type of site, the wind farms tend to be arranged in tightly packed rows, perpendicular to the wind, with large spaces downwind. In northern Europe, the wind, although predominantly from the southwest, also comes from other directions for a significant amount of time, and hence wind turbines tend to be more uniformly spaced in all directions.

The description above focused on the wind speed and wind rose. The other important parameter determining the output of a wind farm is the wind speed distribution. This distribution describes the amount of time on a particular site that the wind speed is between different levels. This characteristic can be very important, but is

often inadequately treated. The distribution is important since it is the combination of the wind speed distribution and the power curve of the proposed turbine which together determine the energy production.

Consider, as an example, two sites, A and B. At one extreme, at Site A, the wind blows at 9 m/s permanently and the wind farm would be very energetic. At the other extreme, at Site B, let us assume that the wind blows at 4 m/s (below cut-in wind speed for a typical wind turbine) for one-third of the time, at 26 m/s (above cut-out wind speed for most turbines) for one-third of the time and at 9 m/s for one-third of the time. The mean wind speed would then be  $(1/3) \times (4 + 9 + 26) = 13$  m/s, much higher than Site A, but the energy yield at Site B would be only a third of that at Site A.

These two examples are both unrealistic, but serve to illustrate a point – that wind speed alone is not enough to describe the potential energy from the site. Some more realistic site wind speed distributions are shown in Figure I.2.7. In this figure, the actual wind speed distribution is shown, as well as a ‘Weibull fit’ to the distribution. The Weibull distribution is a mathematical expression which provides a good approximation to many measured wind speed distributions. The Weibull distribution is therefore frequently used to characterise a site. Such a distribution is described by two parameters: the Weibull ‘scale’ parameter, which is closely related to the mean wind speed, and the ‘shape’ parameter, which is a measurement of the width of the distribution. This approach is useful since it allows both the wind speed and its distribution to be described in a concise fashion. However, as can be seen from the figure, care must be taken in using a Weibull fit. For many sites it may provide a good likeness to the actual wind speed distribution, but there are some sites where differences may be significant.

The annual variability in wind rose and wind speed frequency distribution is also important in assessing the uncertainty in the annual energy production of a wind farm; this is described in detail in the sections below.

Figure I.2.7: Examples of wind speed distributions

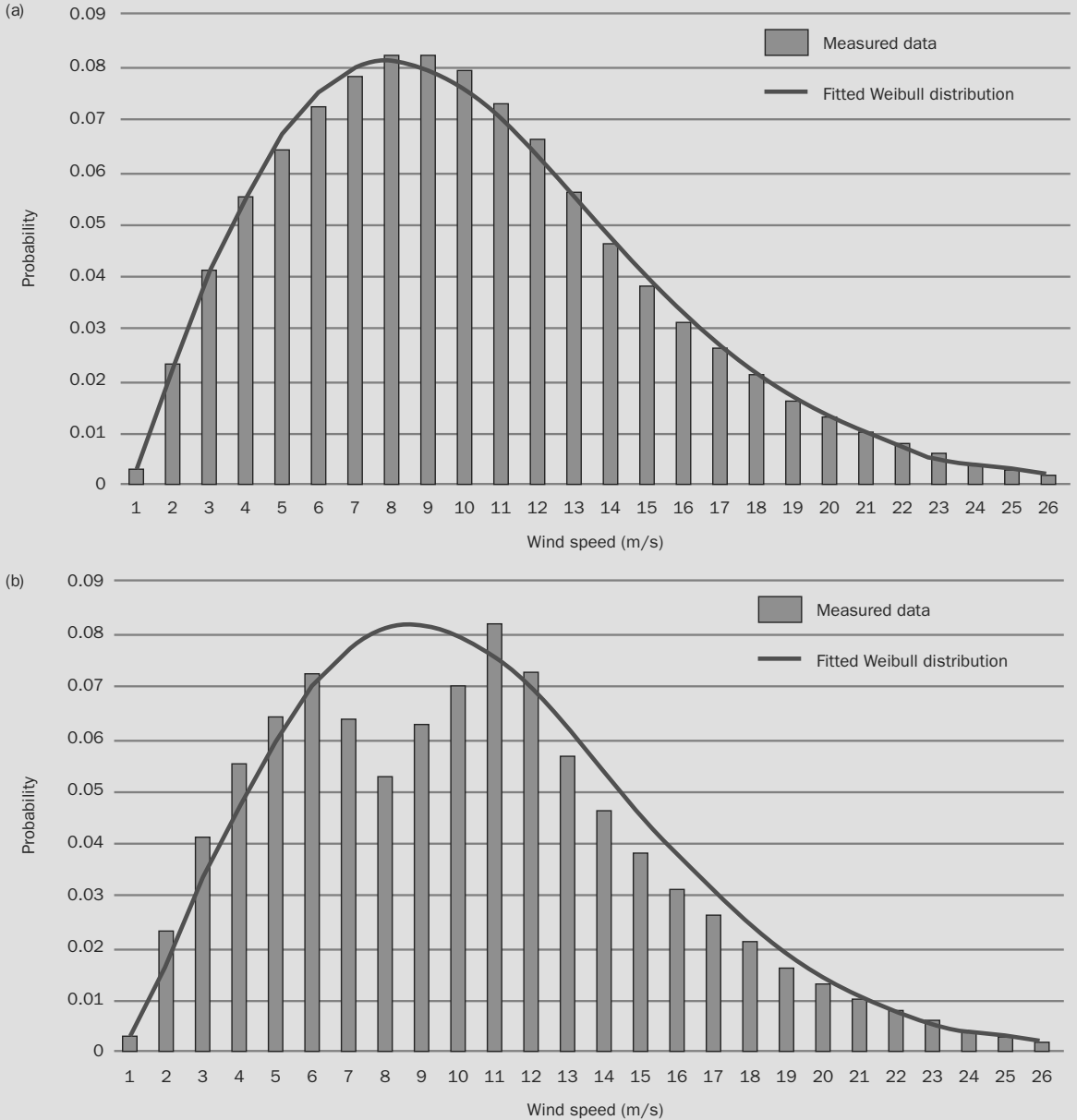

Source: Garrad Hassan

## 44 WIND ENERGY - THE FACTS - TECHNOLOGY

For the purpose of the example, only the variation in annual mean wind speed is considered, as the other factors usually have a secondary effect.

### Variability of One-Year Periods

As discussed above, the annual variability of wind speed has a strong influence on the analysis methodologies developed for the assessment of the long-term wind resource at a site and the uncertainty in such predictions. Before describing typical methodologies used for the prediction of the long-term mean wind speed at a site, an example is given to illustrate typical levels of annual variability of wind speed. The example presented below seeks to answer the following questions:

- If there is one year of wind data available from a potential wind farm site, what error is likely to be associated with assuming that such data is representative of the long term?
- If, instead, there are three years of data available from the site, how does the picture change?

Figure I.2.8a presents the annual mean wind speed recorded at Malin Head Meteorological Station in

Ireland over a 20-year period. It can be seen that there is significant variation in the annual mean wind speed, with maximum and minimum values ranging from less than 7.8 m/s to nearly 9.2 m/s. The standard deviation of annual mean wind speed over the 20-year period is approximately 5 per cent of the mean.

Table I.2.3 presents the average and annual maximum and minimum wind speeds. As an illustration, the equivalent annual energy productions for the example 10 MW wind farm case described earlier are also presented in the table.

Table I.2.3 shows that, had wind speed measurements been carried out on the site for just one year, on the assumption that this year would be representative of the long term, then the predicted long-term wind speed at the site could have had a 10 per cent margin of error. It is often the case that little on-site data is available and hence this situation can arise. In terms of energy production, it is evident that the predicted energy production could be in error by some 14 per cent if the above assumption had been made. For a lower wind speed site, a 10 per cent error in wind speed could easily have a 20 per cent effect on energy production, owing to the higher sensitivity of energy

Figure I.2.8: (a) The annual mean wind speed recorded at Malin Head, Ireland; (b) annual mean wind speed at Malin Head over a 20-year period – three-year rolling averages

(a) Malin Head recorded annual mean wind speed (m/s)

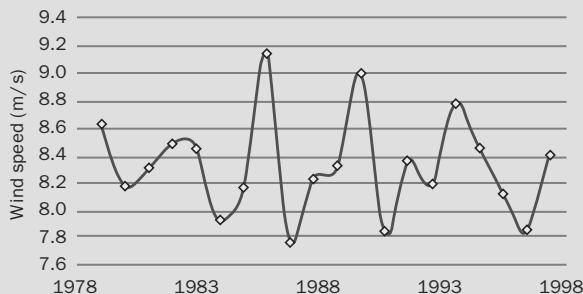

(b) Malin Head recorded annual mean wind speed, three-year rolling average (m/s)

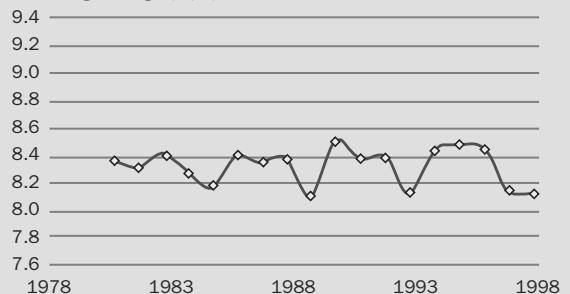



Table I.2.3: Wind speeds and energy production for the average, lowest and highest wind speed year in the period 1979 to 1998, based on a nominal 10 MW wind farm at Malin Head

	Annual mean wind speed (m/s)	Percentage of average year (%)	Energy production (MWh/annum)	Percentage of average year (%)
Lowest wind speed year (1987)	7.77	93.3	29,491	89.8
Average year	8.33	100.0	32,847	100.0
Highest wind speed year (1986)	9.16	110.0	37,413	113.9

production to changes in wind speed at lower wind speeds.

### Variability of Three-Year Periods

Figure I.2.8b illustrates the same data as presented in Figure I.2.8a, but in this instance, a three-year rolling average of the data has been taken. It is immediately apparent that the variability in the mean wind speed over three-year periods is substantially reduced compared with that of one-year periods.

The results presented in Table I.2.3 are reproduced in Table I.2.4, this time based on the highest and lowest three-year averages.

Table I.2.4 illustrates that, if three years' worth of data are available from a site, the maximum deviations in wind speed and energy production over these periods, from long-term averages, is substantially reduced. The deviations of 10 and 14 per cent in wind speed and energy for the analysis based on one-year data sets reduces to deviations of 3 and 4 per cent respectively when three-year periods are considered.

While the results presented here are site-specific, they are broadly representative of any wind farm

in Europe. The reliability of long-term data and the consistency of the wind is a matter that is central to the commercial appraisal of a wind farm. Substantial work has been undertaken to try and identify some key characteristics of the long-term behaviour of wind. This effort consisted of the identification of reliable long-term data sets around the world and attempting to identify common characteristics. One of the results of this approach is illustrated in Figure I.2.9. Data sets of around 30 years in duration have been assembled, and for each site the mean of the 30 annual figures was calculated, together with their standard deviation. The ratio of the standard deviation to the mean was then calculated and it was found that the ratio varied very little from location to location. This feature was observed in many areas across the world – data was collected from Australia, Japan and the US, as well as Europe. This result is useful in determining how much variation in wind is to be expected.

In summary, this work indicated that the annual variability of long-term mean wind speeds at sites across Europe tends to be similar, and can reasonably be characterised as having a normal distribution with a standard deviation of 6 per cent. This result plays an

Table I.2.4: Wind speeds and energy production for the average, lowest and highest three-year periods within the period 1979 to 1998

	Annual mean wind speed (m/s)	Percentage of average year (%)	Energy production (MWh/annum)	Percentage of average year (%)
Lowest wind speed year (1989)	8.10	97.2	31,540	96.0
Average year	8.33	100.0	32,847	100.0
Highest wind speed year (1990)	8.51	102.2	33,871	103.1

Figure I.2.9: Wind map of Europe – Inter-annual variations shown as standard deviation as a percentage of mean

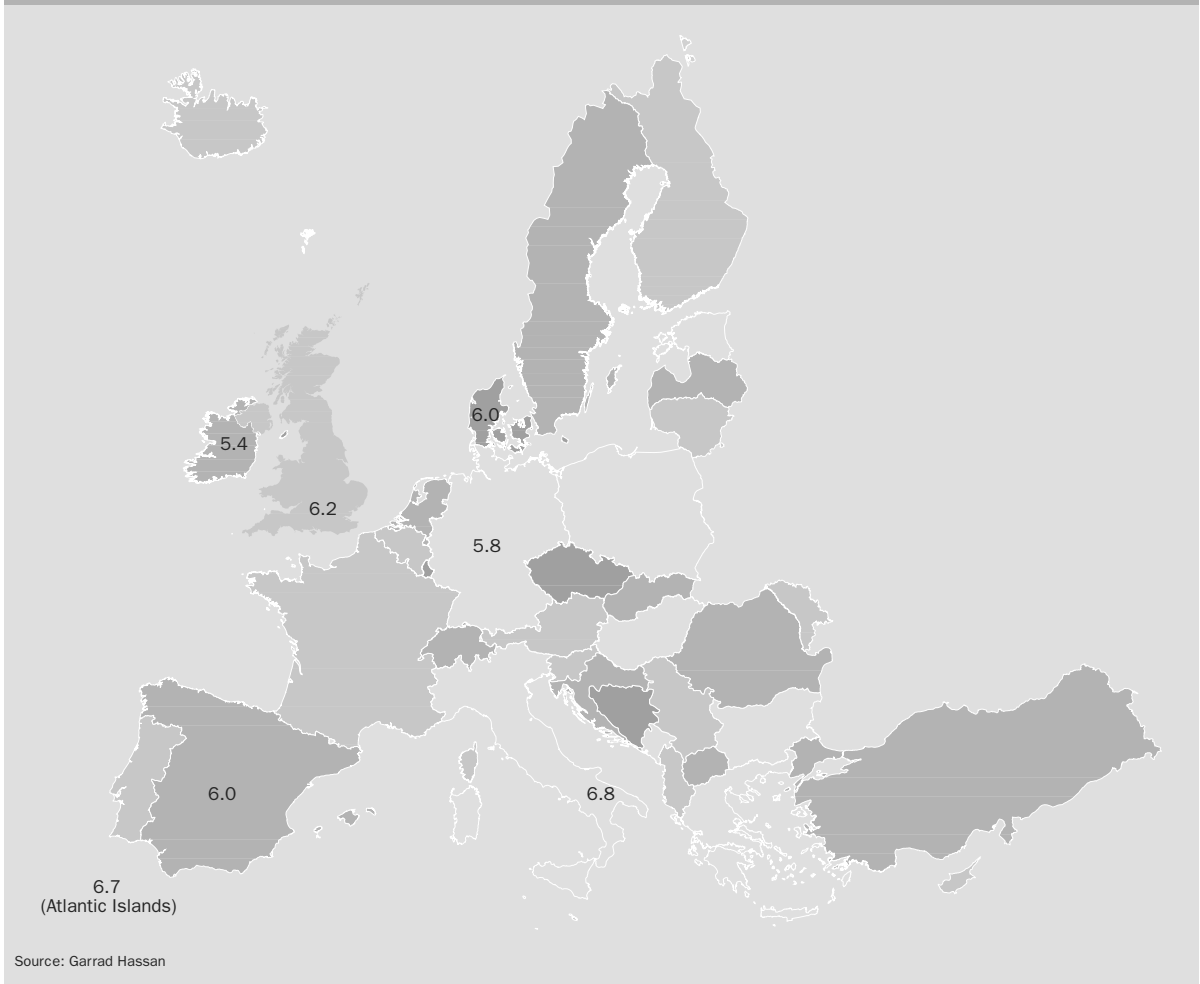

important role in the assessment of the uncertainty in the prediction of wind farm energy production.

### **ANALYTICAL METHODS FOR THE PREDICTION OF THE LONG-TERM WIND REGIME AT A SITE**

From the above, it is clear that the key element of the assessment of the energy production of a proposed wind farm site is the prediction of the long-term wind regime at the site. The outcome of the analyses

described in this section is a long-term wind speed distribution, together with the wind rose. Other meteorological inputs to the energy production analysis are the long-term site air density and site turbulence intensity, a measurement of the 'gustiness' of the wind. These, while still important, are of secondary influence to the energy production of the wind farm, and therefore their derivation is not considered in detail here. It should be noted, however, that the turbulence intensity is very important in determining the loading on a wind turbine, and hence its life expectancy.

## Overview

When assessing the feasibility of a potential wind farm site or where, for strategic purposes, an indication of the variation of wind speed over an area is required, it is unlikely that any wind data from a relatively tall meteorological mast will be available. If there is no on-site data available, the 'wind atlas method' (Troen and Petersen, 1989) is commonly used. This method uses modelling techniques to translate the long-term reference station data to the site. This method can be quite accurate in many cases, but should not replace on-site measurements for more formal wind farm energy assessment. It is also possible to make predictions of the wind speed at a site using a numerical wind atlas methodology, based on a data source such as the 'reanalysis' numerical weather model data sets. Again, such analyses are generally used to assess the feasibility of a site or sites for development.

There are essentially two methods that can be used for the prediction of the long-term wind resource at a site where on-site measurements are available:

- Method 1: Correlate on-site wind data with wind data recorded at a long-term reference station; and
- Method 2: Use only on-site wind data.

Unless a long data set is already available from a site, it is desirable to use Method 1 for the prediction of the long-term wind resource at a site. Typically, a reliable result can be obtained with as little as one year of site data. As illustrated by the example presented for Malin Head Meteorological Station above, if Method 1 cannot be used and Method 2 is used with only one year of data, the uncertainty in the assumption that the year of data recorded is representative of the long term is substantial. Therefore, it is normal practice to find a suitable source of longer-term data in the vicinity of the wind farm site. This allows a correlation analysis to be undertaken and, if only relatively short data sets are available from the site, it is likely to result in an analysis with significantly less

uncertainty than that resulting from use of the site data alone. However, before a data set from a long-term reference station can be used in an analysis, it is vital that thorough checks on the validity of the data for the analysis are undertaken.

Before discussing the details of this approach, it may be helpful to consider the broader picture. It would be ideal if every site benefited from a long-term data set of, say, ten years, measured at hub height. Now and again this happens, but it is very rare. It is, therefore, necessary either to use limited on-site data or to try and use other data to gain a long-term view. The correlation approach can be thought of in the following way. Data is gathered on the site using good quality calibrated equipment. This data provides absolute measurements of the wind speed on the site during the measurement period. If it can be established that there is a close relationship (a good correlation) between the site data and a reference mast, then it will be possible by using the long-term reference data and the relationship to recreate the wind speeds on the site. Thus it is possible to 'pretend' that the long-term wind speed records exist on the site. If a good correlation exists, this is a very powerful technique, but if the correlation is weak, it can be misleading and hence must be used with caution.

Necessary conditions for an off-site wind data set to be considered as a long-term reference are set out below:

- The reference data set includes data which overlaps with the data recorded on site.
- It can be demonstrated that the data has been recorded using a consistent system over the period of both the concurrent and longer-term data. This should include consideration not just of the position and height of the mast and the consistency of equipment used, but also potential changes in the exposure of the mast. For example, the construction of a new building at an airport or the erection of a wind farm near an existing mast will corrupt the data. The absolute values recorded at the

reference station are not important, but any changes to it, in either process or surrounding environment, will render it useless as a reference site. This investigation is therefore very important and is usually done by a physical visit to the site, together with an interview with site staff.

- The exposure of the reference station should be good. It is rare that data recorded by systems in town centres, or where the mean wind speed at the reference station is less than half that of the site, prove to be reliable long-term reference data sets.
- The data is well correlated with that recorded at the site.

Where there have been changes in the consistency of data sample at a reference long-term data source, or where a reliable correlation cannot be demonstrated, it is important that the use of a prospective source of long-term data is rejected. If no suitable reference meteorological station can be found, then the long-term wind resource can only be derived from the data recorded at the site itself. It is likely that longer data sets of two or more years are required to achieve similar certainty levels to those that would have been obtained had a high-quality long-term reference data set been available.

Experience of the analysis of wind energy projects across Europe has indicated that the density of public sources of high-quality wind data is greater in northern Europe than in southern Europe. This observation, combined with the generally more complex terrain in much of southern Europe, often leads to analyses in southern Europe being based on only the data recorded at the wind farm site, or other nearby wind farm sites. In contrast, for analyses in northern Europe, correlation of site data to data recorded at national meteorological stations is more common. Clearly, this observation is a generalisation, however, and there are numerous exceptions. Thus the establishment of a good set of long-term reference masts, specifically for wind energy use in areas of Europe where wind energy projects are likely to be developed, would be an

extremely valuable asset. An EU-wide network of this sort would be highly beneficial.

### **Correlation Methodologies**

The process of comparing the wind speeds on the site with the wind speeds at the reference station, and using the comparison to estimate the long-term wind speed on the site, is called 'measure correlate predict' (MCP). This process is also described in some detail in Appendix D, along with a more detailed discussion of the merits of different methodologies. It is difficult to provide definitive guidance on how poor the quality of a correlation can be before the reference station may no longer be reliably used within an analysis. However, as a general rule, where the Pearson coefficient ( $R^2$ ) of an all-directional monthly wind speed correlation is less than 0.8, there is substantial uncertainty in using long-term data from the reference station to infer long-term wind conditions at the wind farm site.

Once the MCP process has been completed, an estimate exists of the long-term wind speed at the site. This stage – Milestone 1 in Figure I.2.2 – is a very important one, since the position has now been reached at which we have knowledge of the long-term wind speed behaviour at a single point (or points if there are multiple masts) on the site. This estimate will contain both the mean long-term expected value and the uncertainty associated with that value. So far, however, we know nothing of the distribution of the wind speed across the site and neither have we considered the way in which the wind speed values can be converted into energy.

## **THE PREDICTION OF THE ENERGY PRODUCTION OF A WIND FARM**

In order to predict the energy production of the wind farm it is necessary to undertake the following tasks:

- predict the variation in the long-term wind speed over the site at the hub height of the machines, based on the long-term wind speeds at the mast locations;

- predict the wake losses that arise as a result of one turbine operating behind another – in other words in its wake; and
- calculate or estimate the other losses.

### Information Required for an Analysis

In addition to the wind data described in the earlier sections, inputs to this process are typically the following:

- wind farm layout and hub height;
- wind turbine characteristics, including power curve (the curve which plots the power output of a turbine as a function of the wind speed) and thrust curve (the equivalent curve of the force applied by the wind at the top of the tower as a function of wind speed);
- predicted long-term site air density and turbulence intensity (the turbulence intensity is the ‘gustiness’ of the wind);
- definition of the topography over the site and surrounding area; and
- definition of the surface ground cover over the site and surrounding area.

### Energy Production Prediction Methodologies

Typically, the prediction of the variation in wind speed with height, the variation in wind speed over the site area and the wake interaction between wind turbines are calculated within a bespoke suite of computer programs, which are specifically designed to facilitate accurate predictions of wind farm energy production. The use of such tools allows the energy production of different options of layout, turbine type and hub height to be established rapidly once models are set up. Such programs are commonly described as ‘wind farm design tools’ (WFDTs).

Within the WFDT, site wind flow calculations are commonly undertaken, using the WAsP model, which has been widely used within the industry over the past decade. There are also other commercial models,

physically similar to WAsP, that are sometimes used. This area of the wind farm energy calculation is in need of the greatest level of fundamental research and development. Flow models that can be used in commercial wind farm development have to be quick to execute and have to be reliable and consistent. At present, the industry generally opts for simple but effective tools such as WAsP. However, in the last few years, use of computational fluid dynamics (CFD) codes is increasing, although CFD tools are typically used in addition to and not instead of the more simple tools, to investigate specific flow phenomena at more complex sites. CFD tools need to be used with care, as the results are sensitive to modelling assumptions. CFD codes are also substantially more computationally onerous to run. Typical use of CFD tools is, first, to give another estimate of the local acceleration effects or variability at the site, and second, to identify hot spots, in other words areas where the wind conditions are particularly difficult for the wind turbines. In particular, such tools are starting to be used to assist the micro-siting of wind turbines on more complex terrain sites.

Thus, the challenge is to take a topographical map and the long-term wind rose at a known point on the map, and use this information to calculate the long-term wind speed at all the points on the map where the intention is to place wind turbines. A typical set of topographical input and wind contour output (normalised to the wind speed at the location of an on-site mast) is shown in Figure I.2.10 for a hilly area of approximately 6 by 4 km.

The WAsP model does have shortcomings under certain topographical and flow conditions, as the model is designed for specific wind flow conditions. For slopes steeper than approximately 20°, where the flow will separate, the model is beyond its formal bounds of validity. It therefore needs to be used with care and experience and not as a ‘black box’. As indicated above, it does not include ‘viscous effects’, which cause the wind to ‘separate’ as it flows over a sharp change in topography. The WAsP model will follow the

Figure I.2.10: Input topography (left) and output-normalised wind speed (right)

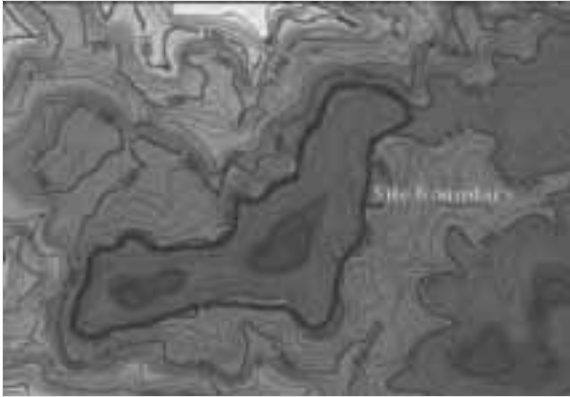

Source: Garrad Hassan

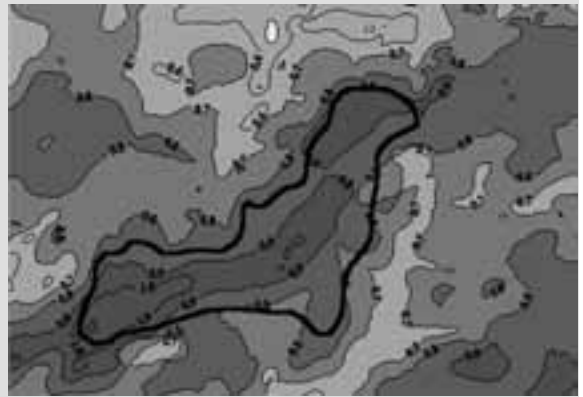

terrain, whereas the real wind will behave as shown in Figure I.2.11. Therefore in complex terrain, the manual interpretation of calculation results is required.

There is an enormous amount of work in progress in all aspects of engineering, quite distinct from the wind energy industry, in which developments are being made in the numerical prediction of complicated flows. Most notably, these efforts centre on aerospace problems – accurate flow over aircraft wings and fuselage, for example, or internal flows in turbo-machinery. Efforts are now being made to apply such models to the arbitrary terrain that defines a wind farm (complex topographies characterising wind farms). There is still a long way to go before these models can be considered sufficiently reliable, however, to replace rather than complement conventional tools.

The energy estimate is only as good as its weakest link, and hence its accuracy is largely defined by this step – the topographical wind model. Data sets now exist that can be used for the validation of new codes, and developments are expected. The task is, nevertheless, a demanding one, and accurate calculation of the flow over steep terrain is challenging. At present, it is necessary to use a mixture of computation and

human insight. For such sites, there is currently no alternative to a comprehensive monitoring campaign to provide data that may be used to initiate localised flow modelling.

Once the topographical effects on the flow have been computed, it is necessary to determine how the individual turbines affect one another – the wake effects. If a turbine is working downstream of another (in its wake), then it will see less wind than it would if it were in the free stream. For some types of wind rose and wind farm design this effect can be significant, of the order of 15 per cent in lost energy, and hence needs to be carefully calculated. The models that

Figure I.2.11: An example of flow separation over a hill

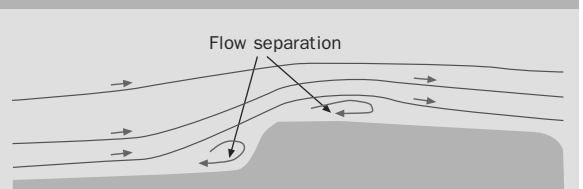

Source: Garrad Hassan

estimate this loss are known as ‘wake models’. Different complexities of wake model are used in the various commercially available WFDTs. These tools are now well validated for a variety of different types of wind farm layout. However, it is well known that they do not work well for very tightly packed wind farms, such as those described above at Palm Springs, and further fundamental work is required to improve the modelling in this area. Also, with the advent of data from large offshore wind farms, it is apparent that some adjustments are required to conventional wake models for very large wind farms.

It is important to appreciate that as the distance of the turbine from the meteorological mast increases, the uncertainty in the prediction also increases. This increase in uncertainty is typically more rapid in complex terrain than in simple terrain. Experience of the decrease in accuracy with distance from the mast, when using models such as WASP, is inherent in making recommendations regarding the appropriate number of meteorological masts for a wind farm site, as discussed above. The WFDTs also allow environmental constraints to be included – areas of the site which may not be used because of rare flora or fauna, noise constraints, visual intrusion, shadow flicker or land ownership, for example. These considerations are discussed in more detail below.

The ability of WFDTs to provide an integrated model of a wind farm also allows them to be used to optimise the wind farm design. This task is performed in an automatic process. It moves the turbines to provide the best possible compromise between concentration of the wind turbines at the maximum wind speed areas of the site, which maximises wake losses (loss of energy by turbulence effects of a wind turbine on its neighbours), and the spreading out of the turbines all over the site to minimise wake loss. This process can be undertaken successfully at the same time as observing the environmental and ownership constraints. The development of these tools has been a significant development in wind farm design. The successful

completion of an energy calculation using a WFDT may be considered as Milestone 2 of Figure I.2.2.

### **Wind Farm Energy Loss Factors**

When WFDTs have been used to predict the output of a wind farm, it is necessary to estimate or calculate a range of potential sources of energy loss. There may be considered to be six main sources of energy loss for wind farms, each of which may be subdivided into more detailed loss factors:

1. the wake effect;
2. availability;
3. electrical efficiency;
4. turbine performance;
5. environmental losses; and
6. curtailments.

A comprehensive list of potential losses is presented in Table I.2.5 below. Several of the loss factors will not be relevant to most projects, but they are listed here for the sake of completeness. Wind farm availability and the influence of tree growth on energy production may be time-dependent factors. As the values in the table below are site-specific, example values have not been presented, although in aggregate the total losses for a wind farm site would typically be in the 10–20 per cent range.

The loss factors used to derive the wind farm net energy output prediction are described below. For each loss factor, a general description is given.

### **Gross Energy Output**

The gross energy production is the energy production of the wind farm obtained by matching the predicted free stream hub height wind speed distribution at each turbine location and the manufacturer’s supplied turbine power curve. In defining the gross energy output, it is assumed that there are no wake interactions between the turbines and none of the loss factors

Table I.2.5: Comprehensive list of loss factors

Wind farm rated power	##.#	MW
Gross energy output	##.#	GWh/annum
<b>1 Wake effect</b>		
1a Wake effect internal	##.#	%
1b Wake effect external	##.#	%
1c Future wake effect	##.#	%
<b>2 Availability</b>		
2a Turbine availability	##.#	%
2b Balance of plant availability	##.#	%
2c Grid availability	##.#	%
<b>3 Electrical efficiency</b>		
3a Operational electrical efficiency	##.#	%
3b Wind farm consumption	##.#	%
<b>4 Turbine Performance</b>		
4a Generic power curve adjustment	##.#	%
4b High wind speed hysteresis	##.#	%
4c Site-specific power curve adjustment	##.#	%
<b>5 Environmental</b>		
5a Performance degradation – non-icing	##.#	%
5b Performance degradation – icing	##.#	%
5c Icing shutdown	##.#	%
5d Temperature shutdown	##.#	%
5e Site access	##.#	%
5f Tree growth (may be time-dependant)	##.#	%
<b>6 Curtailments</b>		
6a Wind sector management	##.#	%
6b Grid curtailment	##.#	%
6c Noise, visual and environmental curtailment	##.#	%
<b>Net energy output</b>	<b>##.#</b>	<b>GWh/annum</b>

**Note:** Sample values for each variable are not included as there are wide ranges of possible values.

listed in the remainder of the energy table are applied. This result includes adjustments to the power curve to account for differences between the predicted long-term annual site air density and the air density to which the power curve is referenced. It also includes the effect of the terrain on the flow.

### Wake Effect

Wind turbines extract energy from the wind and downstream there is a wake from the wind turbine, where wind speed is reduced. As the flow proceeds downstream, there is a spreading of the wake and the wake recovers towards free stream conditions. The wake effect is the aggregated influence on the energy production of the wind farm which results from the changes in wind speed caused by the impact of the turbines on each other.

#### Wake Effect Internal

This is the effect that the wind turbines within the wind farm being considered have on each other.

#### Wake Effect External

This is the effect that the wind turbines from neighbouring wind farms (if any) have on the wind farm being considered.

#### Future Wake Effect

Where future wind farms are to be constructed in the vicinity of the project under consideration, the wake effect of these has to be estimated and taken into account. If appropriate, this factor can be derived as a profile over the project lifetime.

### Availability

Wind turbines, the balance of plant infrastructure and the electrical grid will not be available the whole time. Estimates are included for likely levels of availability for these items, averaged over the project lifetime.

#### Turbine Availability

This factor defines the expected average turbine availability of the wind farm over the life of the project. It represents, as a percentage, the factor which needs



to be applied to the gross energy to account for the loss of energy associated with the amount of time the turbines are unavailable to produce electricity.

#### **Balance of Plant (BOP) Availability**

This factor defines the expected availability of the turbine transformers, the on-site electrical infrastructure and the substation infrastructure up to the point of connection to the grid of the wind farm. It represents, as a percentage, the factor that needs to be applied to the gross energy to account for the loss of energy associated with the downtime of the balance of plant.

#### **Grid Availability**

This factor defines the expected grid availability for the wind farm in mature operation. It is stressed that this factor relates to the grid being outside the operational parameters defined within the grid connection agreement, as well as actual grid downtime. This factor also accounts for delays in the wind farm coming back to full operation following a grid outage. It represents, as a percentage, the factor that needs to be applied to the gross energy to account for the loss of energy associated with the downtime of the grid connection.

#### **Electrical Efficiency**

There will be electrical losses experienced between the low voltage terminals of each of the wind turbines and the wind farm point of connection, which is usually located within a wind farm switching station.

#### **Operational Electrical Efficiency**

This factor defines the electrical losses encountered when the wind farm is operational and which will be manifested as a reduction in the energy measured by an export meter at the point of connection. This is presented as an overall electrical efficiency, and is

based on the long-term average expected production pattern of the wind farm.

#### **Wind Farm Consumption**

This factor defines the electrical efficiency including electrical consumption of the non-operational wind farm, such as consumption by electrical equipment within the turbines and substation. In most cases, this issue is omitted from the list of loss factors, and is instead considered as a wind farm operational cost. However, for some metering arrangements, it may be appropriate to include this as an electrical efficiency factor, rather than an operational cost, and so this factor is included within the table.

#### **Turbine Performance**

In an energy production calculation, a power curve supplied by the turbine supplier is used within the analysis.

#### **Generic Power Curve Adjustment**

It is usual for the supplied power curve to represent accurately the power curve that would be achieved by a wind turbine on a simple terrain test site, assuming the turbine is tested under an IEC power curve test. For certain turbine models, however, there may be reason to expect that the supplied power curve does not accurately represent the power curve that would be achieved by a wind turbine on a simple terrain site under an IEC power curve test. In such a situation, a power curve adjustment is applied.

#### **High Wind Hysteresis**

Most wind turbines will shut down when the wind speed exceeds a certain limit. High wind speed shutdown events can cause significant fatigue loading. Therefore, to prevent repeated start-up and shutdown of the turbine when winds are close to the shutdown threshold,

hysteresis is commonly introduced into the turbine control algorithm. Where a detailed description of the wind turbine cut-in and cut-out parameters are available, this is used to estimate the loss of production due to high wind hysteresis, by repeating the analysis using a power curve with a reduced cut-out wind speed.

### Site-Specific Power Curve Adjustment

Wind turbine power curves are usually based on power curve measurements, which are made on simple terrain test sites. Certain wind farm sites may experience wind flow conditions that materially differ from the wind flow conditions seen at simple terrain test sites. Where it is considered that the meteorological parameters in some areas of a site differ substantially from those at a typical wind turbine test station, then the impact on energy production of the difference in meteorological parameters at the site compared with a typical power curve test site is estimated. This may be undertaken where turbulence or up-flow angle are considered to be substantially different at the wind farm site to that which is experienced at a typical test site, and sufficient data is available to make the appropriate adjustments.

### Environmental

In certain conditions, dirt can form on the blades, or over time the surface of the blade may degrade. Also, ice can build up on a wind turbine. These influences can affect the energy production of a wind farm in the ways described below. Extremes of weather can also affect the energy production of a wind farm; these are also described below.

### Performance Degradation – Non-icing

The performance of wind turbines can be affected by blade degradation, which includes the accretion of dirt (which may be washed off by rain from time to time),

as well as physical degradation of the blade surface over prolonged operation.

### Performance Degradation – Icing

Small amounts of icing on the turbine blades can change the aerodynamic performance of the machine, resulting in loss of energy.

### Icing Shutdown

As ice accretion becomes more severe, wind turbines will shut down or will not start. Icing can also affect the anemometer and wind vane on the turbine nacelle, which may also cause the turbine to shut down.

### Temperature Shutdown

Turbines are designed to operate over a specific temperature range. For certain sites, this range may be exceeded, and for periods when the permissible temperature range is exceeded, the turbine will be shut down. For such sites, an assessment is made to establish the frequency of temperatures outside the operational range, and the correlation of such conditions with wind speed. From this, the impact on energy production is estimated.

### Site Access

Severe environmental conditions can influence access to more remote sites, which can affect availability. An example of this might be an area prone to severe snow drifts in winter.

### Tree Growth/Felling

For wind farm sites located within or close to forests or other areas of trees, the impact of how the trees may change over time and the effect that this will have on the wind flow over the site, and consequently the energy production of the wind farm, must be

considered. The impact of the future felling of trees, if known, may also need to be assessed.

### **Curtailments**

Some or all of the turbines within a wind farm may need to be shut down to mitigate issues associated with turbine loading, export to the grid or certain planning conditions.

### **Wind Sector Management**

Turbine loading is influenced by the wake effects from nearby machines. For some wind farms with particularly close machine spacing, it may be necessary to shut down certain turbines for certain wind conditions. This is referred to as wind sector management, and will generally result in a reduction in the energy production of the wind farm.

### **Grid Curtailment**

Within certain grid connection agreements, the output of the wind farm is curtailed at certain times. This will result in a loss of energy production. This factor also includes the time taken for the wind farm to become fully operational following grid curtailment.

### **Noise, Visual and Environmental Curtailment**

In certain jurisdictions, there may be requirements to shut down turbines during specific meteorological conditions to meet defined noise emission or shadow flicker criteria at nearby dwellings or due to environmental requirements related to birds or bats.

## **DEFINITION OF UNCERTAINTY IN THE PREDICTED ENERGY PRODUCTION**

Uncertainty analysis is an important part of any assessment of the long-term energy production of a

wind farm. Although an uncertainty analysis needs to be considered on a site-specific basis, the process can be described as follows:

- identify the different inputs to and processes within the analysis;
- assign an uncertainty to each of these elements, both in terms of the magnitude of the uncertainty and the shape of the distribution;
- convert each of the uncertainties into common units of energy;
- combine the various uncertainties to define a total uncertainty for the entire prediction; and
- present uncertainty statistics at requested levels.

Research work reported in Raftery et al. (1999) defined a comprehensive risk register for wind power projects and included detailed Monte Carlo-based analysis techniques to assess the uncertainty in the results obtained. Based on the results of this work, use of an uncertainty analysis with a number of simplifying assumptions can be justified. The main simplifying assumptions are that it is reasonable to consider a relatively small number of key uncertainties and that these individual uncertainties can be assumed to be normally distributed. Making these assumptions, it is possible to define energy production levels with a defined probability of those levels being exceeded.

It is common to present uncertainty results for both a long future period of, say, ten years and also for a shorter future period of one year. It is now normal practice for such figures, in parallel with a central estimate for the production of a wind farm, to be used to inform investment decisions for projects.

The uncertainty analyses presented within energy assessments typically assume that the turbines will perform exactly to the defined availability and power performance levels. The power performance and availability levels are usually covered by specific warranty arrangements, and hence any consideration of the uncertainty in these parameters needs machine-specific and contract-specific review, which is generally

outside the scope of a 'standard' energy analysis. However, it is increasingly the norm to assign a moderate uncertainty to the estimated availability, loss factor and power performance factors, to reflect that small deviations from expected availability and power performance levels may not be sufficient to trigger damage payments under the warranty. Uncertainty in the energy estimates is a vital part of the result.

## Forecasting

This chapter has so far considered only the industry's ability to estimate long-term energy production for a wind farm. Usually, this is the most important task, since, to date, most of the power purchase agreements are 'take or pay', meaning that the utility or other customer is obliged to buy all the energy produced by the wind farm. As the penetration of wind power generation increases (in terms of the overall energy mix), fluctuations in energy output (caused by variations in wind speed) will be more visible on the electrical system. Transmission system operators (TSOs) working to balance supply and demand on regional or national grid systems will need to predict and manage this variability to avoid balancing problems. The point at which this is required changes from system to system, but it has been observed as becoming important when penetration of wind energy reaches about 5 per cent of installed capacity.

As the level of penetration of wind energy into individual grids increases, it will become necessary to make wind farms appear much more like conventional plants and hence it will be necessary to forecast, at short to medium timescales (one hour to seven days), how much energy will be produced. In some countries, forecasting is already required. New wind farms in California are required to 'use the best possible means available' to forecast the output, and send such estimates to Cal ISO (the California independent system operator). In European countries where there is already a high level of penetration, such as Spain, Germany and Denmark,

operators, managers and TSOs are routinely forecasting the output from their wind farms. These forecasts are used to schedule the operations of other plants, and are also used for trading purposes.

Forecasting the wind energy production will grow in importance as the level of installed capacity grows. The wind industry must expect to do its very best to allow the TSOs to use wind energy to its best effect, which means aggregated output forecasts from wind farms must be accurate. In the UK, where the market is already deregulated, energy traders are using sophisticated forecasts to trade wind energy on the futures market.

At the same time as improving the predictability of the output of wind energy plants through improvements in forecasting techniques, awareness of the true behaviour of conventional plants should be considered. In order to provide the best mix of plants and technologies, it will be important for all the different energy forms to be considered on an equitable basis. Therefore the proper, formal statistical analysis of both renewable and conventional plants is important. This task should be considered as an essential element of a wind energy development strategy and must be conducted on a total power system approach.

As a result of its strategic importance as described above, forecasting has been the focus of considerable technical attention in recent years. A good source of general review materials, as well as detailed papers, can be found in Landberg et al. (2003). Although there are a variety of different techniques being used, they all share similar characteristics. It is therefore possible to provide a generic description of the techniques presently being used, whereby data is provided by a weather forecast, and production data is provided by the wind farms. The two sets of data are combined to provide a forecast for future energy production. Figure I.2.12 provides a schematic picture of typical forecasting approach.

To integrate wind energy successfully into an electricity system at large penetration levels of more than

Figure I.2.12: A schematic representation of a forecasting approach

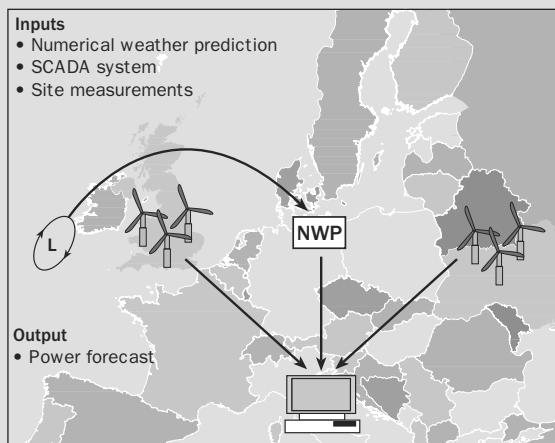

10 per cent, accurate wind energy predictions are needed.

The numerical weather prediction (NWP) models run by national institutes are typically of continental, if not global, scale. Consequently, their resolutions tend to be too coarse for wind energy needs. The model run by the Danish Meteorological Institute for northwest Europe, for example, has a minimum horizontal resolution of approximately 5 km.

The methods of achieving the transformation between coarse NWP forecasts and site-specific ones are varied. Despite this variation, they can largely be grouped into two main types:

1. physical models; and
2. statistical models.

Physical models primarily aim to improve the resolution of the 'original' NWP model. The models used to achieve this can include:

- simple linear-flow models such as WAsP; and
- high-resolution NWP models: these are essentially local (nested) meso-scale versions of the original

NWP model, and are often termed 'storm-scale' or 'convective-scale'; they aim to model local thermal and terrain effects that are not apparent at the coarse scale.

The following aspects of the physical model approach need to be considered:

- skill – the implementation of local meso-scale models requires the skill and competency of a meteorologist; there is always the possibility of a poorly formed model introducing further errors; and
- computational requirements – the formulation and execution of the models are computationally expensive.

## OVERVIEW OF THE METHOD

There are several groups (see, for example, Landberg et al., 2003; Martf et al., 2000; Moehrlen et al., 2000) working in this area and they all have slightly different approaches. However, in all cases, the creation of power output forecasts is a two-stage process. First, there is the creation of site-specific meteorological forecasts (for some predefined reference point, such as a site met mast). These meteorological forecasts are then transformed, via site-specific power models, to power output forecasts. This process is shown schematically in Figure I.2.13.

To enable the meteorological model to be both autoregressive and adaptive, feedback data from the site is also required. In other words, the method needs to know what is happening at the site where predictions are being made, as well as using the forecast. If it does so, it can 'learn' and also can adjust the forecasts, depending on the degree of success.

## EXAMPLES OF TIME SERIES POWER PREDICTION RESULTS

An example of time series plots for two separate forecast horizons is shown in Figure I.2.14. It shows

Figure I.2.13: Method overview

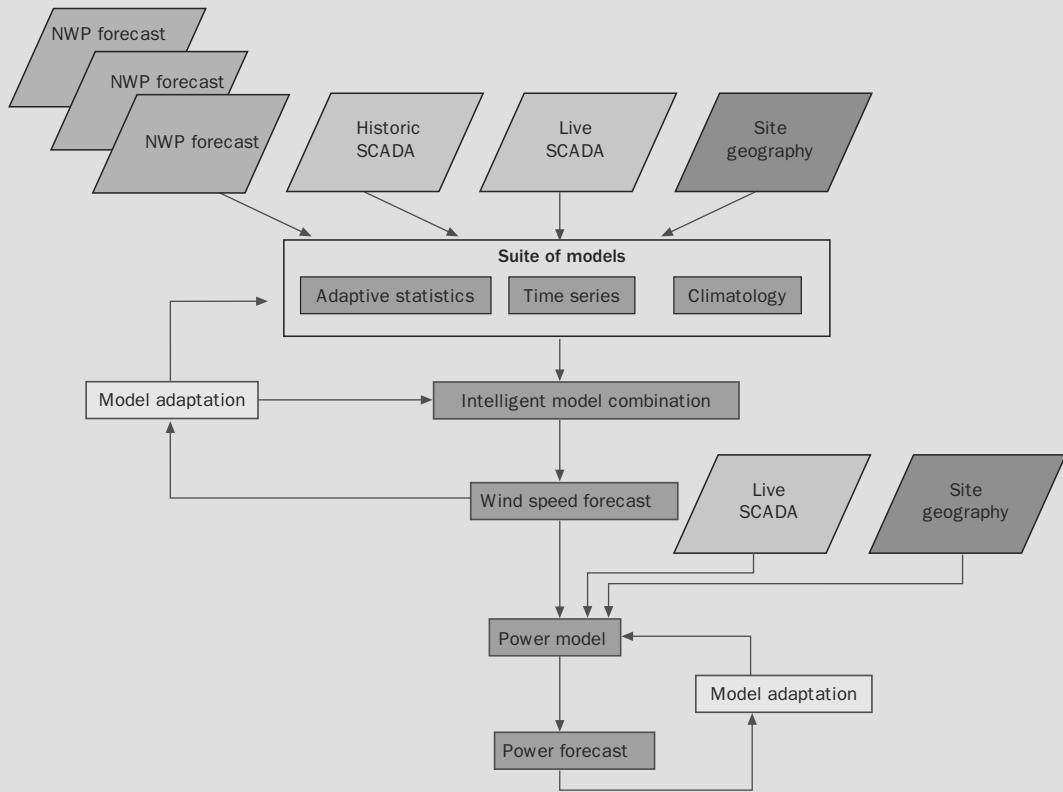

**Note:** NWP is numerical weather prediction and SCADA is supervisory control and data acquisition.

Source: Garrad Hassan

how well the model predicted the power output of the wind farm, both 1 hour ( $T + 1$ ) and 12 hours ( $T + 12$ ) in advance. Also shown within the figure are 'P10', 'P25', 'P75' and 'P90' error bars associated with the prediction: for example the P75 level is a power level with a 75 per cent probability of being exceeded.

To an 'engineering eye' this prediction looks good. It is clear that the forecast has captured the shape of the profile rather well. To the 'commercial eye', however, the situation is not so good. For example, on 1 February, there was greater volatility in the

power output than predicted. For hourly trading purposes, such a prediction would then be poor. Whether or not the forecast is 'good' or 'bad' therefore depends very strongly on its precise purpose. For scheduling plant maintenance it is acceptable, whereas for hourly trading it is poor. The purpose of the forecast thus needs to be very carefully defined; this is a strategic as well as a technical question. That said, forecasts of the accuracy of that defined in Figure I.2.14 are currently substantially increasing the value of wind energy in some markets and where suitable commercial trading strategies are employed, and in

Figure I.2.14: Time series of power forecast, T + 1 (left) and T + 12 (right)

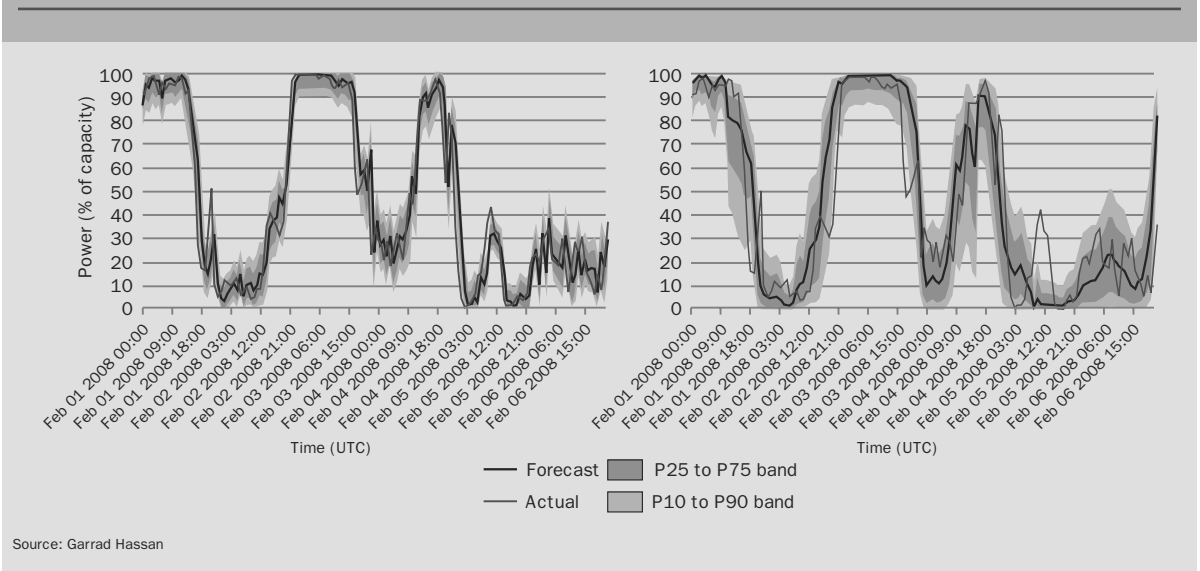

other markets such forecasts help TSOs balance the system.

**EXAMPLE STATISTICAL ACCURACY OF FORECASTS**

To better understand the accuracy of a forecast and set the ‘snap shot’ time series results presented above into a more statistical long-term context, it is necessary to look at a particular measure of accuracy over time. There are several different measures that can be used, but a commonly used measure is to present the mean absolute error of the forecast, normalised by the rated capacity of the wind farm, against forecast horizon. Forecast accuracy is discussed further in Madsen et al. (2005). The accuracy achieved is, of course, dependent on the specifics of the wind regime and the complexity of the site, as well as the country where the wind farm is located. An example of the typical range of accuracies achieved by state-of-the-art forecasting methods is presented in Figure I.2.15.

**PORTFOLIO EFFECTS**

As the geographical spread of an electricity system increases, the wind speeds across it become less correlated. Some areas will be windy; some will not.

Figure I.2.15: Typical range of forecast accuracy for individual wind farms

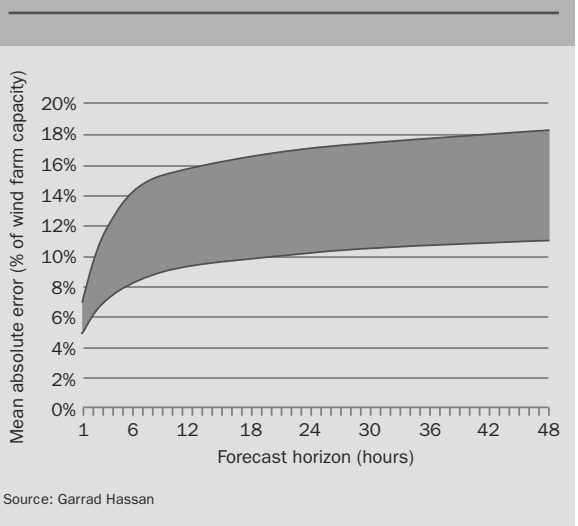

Some areas will have rising power output; some will have falling power output. The effect of aggregation on wind farm power fluctuations, and on capacity credit issues, has been looked at by several analysts, and forecasting of the output of large numbers of wind farms for the system operator is now commonplace in both Denmark and Germany.

As can be imagined, forecast accuracy for portfolios of wind farms is better than for individual wind farms. An example time series plot of the forecast accuracy of a portfolio of seven geographically dispersed wind farms is presented in Figure I.2.16. It can be seen that the average deviation of the forecast is significantly lower than that for the individual wind farm example presented in Figure I.2.14, despite the portfolio being forecast 24 hours in advance rather than 12 hours. It would be typical for the mean absolute error of the forecast 24 hours in advance to be 3 to 5 per cent lower for a portfolio of seven wind farms than that for one individual wind farm. As forecasts are extended to include all wind farms in a region, such as a part of Germany or Denmark, where densities of turbines are

high, then mean absolute errors of only 5–7 per cent are seen even 24 to 48 hours in advance.

## CONCLUSIONS

There is now a range of sophisticated modelling tools which can provide robust short-term forecasts of the output of wind farms and portfolios of wind farms. These models are being used in various markets for a range of different purposes. Key areas of use are by TSOs to facilitate balancing of the grid, by energy traders to trade energy from wind farms on futures markets and by wind farm owners to optimise O&M arrangements.

The use of wind energy forecasts in many countries is at an embryonic stage and there are substantial benefits to be gained from the wider adoption of current state-of-the-art forecasting in all of the areas mentioned above. In addition, changes need to be made in the way the power systems are operated and the markets are functioning. The tools are available; they just need to be more widely used.

Figure I.2.16: Time series of power forecast for a portfolio of seven wind farms at T + 24

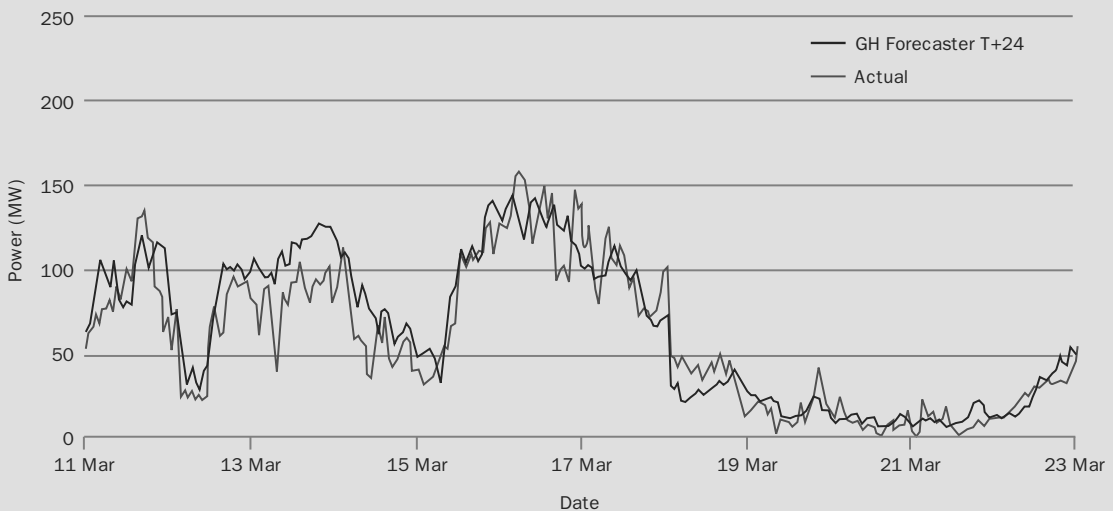



There is substantial ongoing work aimed at improving the forecast tools. There are two main aspects to this work. First, global-level weather models, which are behind all sophisticated short-term forecast models, are continuously improving, due to:

- the availability of greater computing power;
- a better understanding of the physics; and
- more numerous input data from sources, such as satellites and aeroplanes.

Second, and in parallel with such advances, the short-term forecasters specifically serving the wind industry are continually improving models. A key practical way in which models are improving is due to improvements in wind farm SCADA (supervisory control and data acquisition) systems, meaning an increase in the quality of the information flowing back from the wind farm to be used in the forecast.

## Future Developments

Wind speed and energy prediction are, and will remain, a very critical part of the development of a wind farm. Enormous investments are made based on the estimates provided. Lender and investor confidence must be maintained or improved. Improvement in these techniques is, therefore, an important part of European and global wind energy development. Below is a list of important topics for future development.

- An intention of this chapter is to introduce some of the challenges of predicting the future output of wind farms to non-wind analysis specialists involved in the wind industry. Speaking in general terms, for a typical site, the energy production level with a 90 per cent chance of being exceeded (P90 level) may well be 15 per cent below the central estimate energy production (P50) level. Put another way, one in ten projects analysed may be expected to have an energy production in the long term more than 15 per cent below the central estimate level. Of course, in a similar way, statistically one in ten

projects may be expected to exceed the central estimate production level by 15 per cent. The challenge is therefore to improve the accuracy of the models and methods.

- In addition to this, the production will vary substantially from year to year, due to annual variations in the wind regime. Also, the relatively high levels of availability met by most modern wind farms only happen if the right O&M structures and budgets are in place. Neglect in these areas can cause wind farms to produce significantly less than their potential output.
- To a high degree, the accuracy of the pre-construction prediction of the energy production of a wind farm is in the hands of the owner. The better the site wind measurements, the lower the uncertainty and the lower the likelihood of surprises once the wind farm is operational. It is recommended that in-house or external experts are involved to carefully design a monitoring strategy for all wind farm developments, and that this area of a development is adequately funded.
- Assessment methods for wind farms are continuously improving and key areas of development include:
  - the use of increasingly sophisticated flow modelling techniques;
  - further validation of wake models;
  - optimisation of the use of data sources that are not on the wind farm site to adjust site data to be representative of the long term;
  - the use of remote sensing techniques to measure wind speed;
  - improved estimates of 'loss factors'; and
  - more sophisticated approaches to uncertainty analysis.
- A central principle of the development of improved scientific predictions is the refinement and validation of models against measured data. Wind farm SCADA systems are recording huge volumes of data. It is considered that the quality of SCADA data recorded at wind farm sites is improving, but needs further improvement. Also, SCADA data from

## 62 WIND ENERGY - THE FACTS - TECHNOLOGY

wind farms contains information that will allow the further validation of models and assumptions used in energy assessment. The challenge for the industry is to focus on understanding what that data tells us and, where appropriate, amending models, techniques and assumptions.

- The wind industry needs to work more closely with climate change scientists to better understand how weather patterns may change in the future.

High-quality short-term forecasting techniques are available now. The initial challenge for the industry is to extract the maximum value from the existing state-of-the-art forecast models. At present, the use of such techniques to address some of the fundamental challenges for the integration of wind energy into the grid is patchy. In parallel with the increased use of existing tools, continued effort needs to be focused on improving forecasting technology.





## I.3 WIND TURBINE TECHNOLOGY

### Evolution of Commercial Wind Turbine Technology

The engineering challenge for the wind industry is to design an efficient wind turbine to harness wind energy and turn it into electricity. In this chapter, the evolution of wind turbines is discussed, their present status described and the future challenges identified.

The evolution of modern wind turbines is a story of engineering and scientific skill, coupled with a strong entrepreneurial spirit. In the last 20 years, turbines have increased in size by a factor of 100 (from 25 kW to 2500 kW and beyond), the cost of energy has reduced by a factor of more than five and the industry has moved from an idealistic fringe activity to an acknowledged component of the power generation industry. At the same time, the engineering base and computational tools have developed to match machine size and volume. This is a remarkable story, but it is far from finished: many technical challenges remain and even more spectacular achievements will follow.

### THE TECHNICAL CHALLENGE OF A UNIQUE TECHNOLOGY

The concept of a wind-driven rotor is ancient, and electric motors were widely disseminated, both domestically and commercially, in the latter half of the 20th century. Making a wind turbine may seem simple, but it is a big challenge to produce a wind turbine that:

- meets specifications (frequency, voltage, harmonic content) for standard electricity generation, with each unit operating as an unattended power station;
- copes with the variability of the wind (mean wind speeds on exploitable sites range from 5 to 11 m/s, with severe turbulence in the Earth's boundary layer and extreme gusts up to 70 m/s); and
- competes economically with other energy sources.

The traditional 'Dutch' windmill (Figure I.3.1) had proliferated to the extent of about 100,000 machines throughout Europe at their peak in the late 19th century. These machines preceded electricity supply and were indeed wind-powered mills used for grinding grain. Use of the wind for water pumping also became common. The windmills were always attended, sometimes inhabited and largely manually controlled. They were also characterised by direct use of the mechanical energy generated on the spot. They were integrated within the community, designed for frequent replacement of certain components and efficiency was of little importance.

In contrast, the function of a modern power-generating wind turbine is to generate high-quality, network frequency electricity. Each wind turbine must function as an automatically controlled independent 'mini-power station'. It is unthinkable for a modern wind turbine to be permanently attended, and uneconomic for it to be frequently maintained. The development of the microprocessor has played a crucial role in enabling cost-effective wind technology. A modern wind turbine is required to work unattended, with low maintenance, continuously for in excess of 20 years.

Figure I.3.1: Traditional 'Dutch' windmill



### Stall

Although most of the largest wind turbines now employ active pitch control, in the recent history of wind turbine technology, the use of aerodynamic stall to limit power has been a unique feature of the technology. Most aerodynamic devices (aeroplanes and gas turbines, for example) avoid stall. Stall, from a functional standpoint, is the breakdown of the normally powerful lifting force when the angle of flow over an aerofoil (such as a wing section) becomes too steep. This is a potentially fatal event for a flying machine, whereas wind turbines can make purposeful use of stall as a means of limiting power and loads in high wind speeds.

The design requirements of stall regulation led to new aerofoil developments and also the use of devices, such as stall strips, vortex generators, fences and Gurney flaps, for fine-tuning rotor blade performance. Even when not used to regulate power, stall still very much influences aerofoil selection for wind turbines. In an aircraft, a large margin in stall angle of attack, compared to the optimum cruising angle, is very desirable. On a wind turbine, this may be undesirable and lead to higher extreme loads.

### Fatigue

The power train components of a wind turbine are subject to highly irregular loading input from turbulent wind conditions, and the number of fatigue cycles experienced by the major structural components can be orders of magnitude greater than for other rotating machines. Consider that a modern wind turbine operates for about 13 years in a design life of 20 years and is almost always unattended. A motor vehicle, by comparison, is manned, frequently maintained and has a typical operational life of about 160,000 km, equivalent to four months of continuous operation.

Thus in the use rather than avoidance of stall and in the severity of the fatigue environment, wind technology has a unique technical identity and unique R&D demands.

## THE DEVELOPMENT OF COMMERCIAL TECHNOLOGY

An early attempt at large-scale commercial generation of power from the wind was the 53 m diameter, 1.25 MW Smith Putnam wind turbine, erected at Grandpa's Knob in Vermont, US, in 1939. This design brought together some of the finest scientists and engineers of the time (the aerodynamic design was by von Karman and the dynamic analysis by den Hartog). The wind turbine operated successfully for longer than some megawatt machines of the 1980s.

It was a landmark in technological development and provided valuable information about quality input to design, machine dynamics, fatigue, siting and sensitivity. However, preceding the oil crisis of the 1970s, there was no economic incentive to pursue the technology further in the post-war years.

The next milestone in wind turbine development was the Gedser wind turbine. With assistance from Marshall Plan post-war funding, a 200 kW, 24 m diameter wind turbine was installed during 1956 and 1957 in the town of Gedser in the southeast of Denmark. This machine operated from 1958 to 1967 with about a 20 per cent capacity factor.

In the early 1960s, Professor Ulrich Hütter developed high tip speed designs, which had a significant influence on wind turbine research in Germany and the US.

### 1970 to 1990

In the early 1980s, many issues of rotor blade technology were investigated. Steel rotors were tried but rejected as too heavy, aluminium as too uncertain in

the context of fatigue endurance, and the wood-epoxy system developed by Gougeon Brothers in the US was employed in a number of both small and large wind turbines. The blade manufacturing industry has, however, been dominated by fibreglass polyester construction, which evolved from the work of LM Glasfiber, a boat-building company, and became thoroughly consolidated in Denmark in the 1980s.

By 1980 in the US, a combination of state and federal energy and investment tax credits had stimulated a rapidly expanding market for wind in California. Over the 1980–1995 period, about 1700 MW of wind capacity was installed, more than half after 1985 when the tax credits had reduced to about 15 per cent.

Tax credits attracted an indiscriminate overpopulation of various areas of California (San Geronio, Tehachapi and Altamont Pass) with wind turbines, many of which were ill-designed and functioned poorly. However, the tax credits created a major export market for European (especially Danish) wind turbine manufacturers, who had relatively cost-effective, tried and tested hardware available. The technically successful operation of the later, better-designed wind turbines in California did much to establish the foundation on which the modern wind industry has been built. The former, poor quality turbines conversely created a poor image for the industry, which has taken a long time to shake off.

### 1990 to Present

The growth of wind energy in California was not sustained, but there was striking development in European markets, with an installation rate in Germany of around 200 MW per annum in the early 1990s. From a technological standpoint, the significant outcome was the development of new German manufacturers and of some new concepts. The introduction of innovative direct drive generator technology by the German manufacturer Enercon is particularly noteworthy. Subsequently, a huge expansion of the Spanish market

occurred, including wind farm development, new designs and new manufacturers.

Over this period there have been gradual, yet significant, new technological developments in direct drive power trains, in variable speed electrical and control systems, in alternative blade materials, and in other areas. However, the most striking trend in recent years has been the development of ever larger wind turbines, leading to the current commercial generation of multi-megawatt onshore and offshore machines.

## DESIGN STYLES

Significant consolidation of design has taken place since the 1980s, although new types of electrical generators have also introduced further diversification.

### Vertical Axis

Vertical axis wind turbine (VAWT) designs were considered, with expected advantages of omnidirectionality and having gears and generating equipment at the tower base. However, they are inherently less efficient (because of the variation in aerodynamic torque with the wide range in angle of attack over a rotation of the rotor). In addition, it was not found to be feasible to have the gearbox of large vertical axis turbines at ground level, because of the weight and cost of the transmission shaft.

The vertical axis design also involves a lot of structure per unit of capacity, including cross arms in the H-type design (Figure I.3.2). The Darrieus design (Figure I.3.3) is more efficient structurally. The blade shape is a so-called ‘troposkein curve’ and is loaded only in tension, not in bending, by the forces caused as the rotor spins. However, it is evident that much of the blade surface is close to the axis. Blade sections close to the axis rotate more slowly and this results in reduced aerodynamic efficiency. The classic ‘egg-beater’ shaped Darrieus rotors also suffered

Figure I.3.2: H-type vertical axis wind turbine

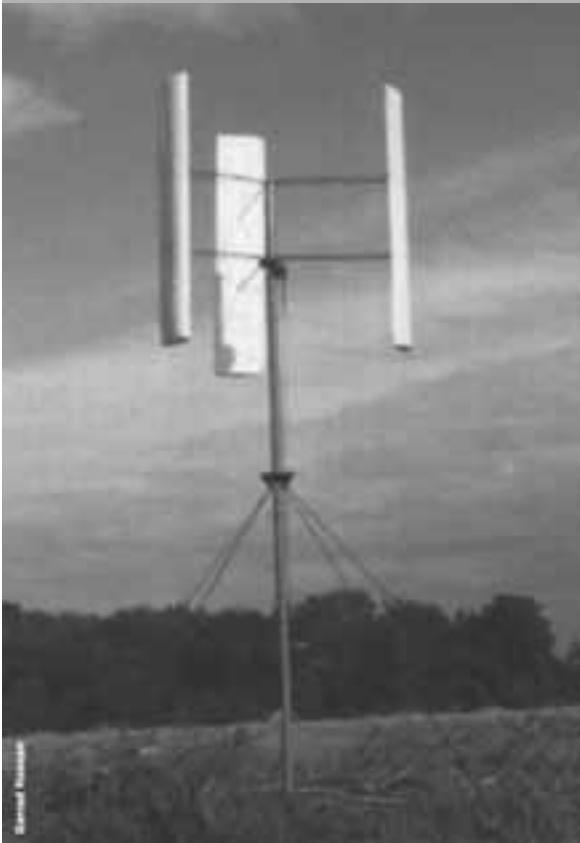

from a number of serious technical problems, such as metal fatigue-related failures of the curved rotor blades. These disadvantages have caused the vertical axis design route to disappear from the mainstream commercial market. FlowWind, previously the main commercial supplier of vertical axis turbines, stopped supplying such machines over a decade ago.

Although there is not yet any substantial market penetration, there has recently been a remarkable resurgence of innovative VAWT designs in the category of small systems for diverse applications, especially on rooftops of buildings, and also some innovative

Figure I.3.3: Darrieus type vertical axis wind turbine



designs have also been made for large-scale offshore applications.

### Number of Blades

Small-scale, multi-bladed turbines are still in use for water pumping. They are of relatively low aerodynamic efficiency but, with the large blade area, can provide a high starting torque (turning force). This enables the rotor to turn in very light winds and suits a water pumping duty.

Most modern wind turbines have three blades, although in the 1980s and early 1990s some attempt was made to market one- and two-bladed wind turbine designs.

The single-bladed design (Figure I.3.4) is the most structurally efficient for the rotor blade, as it has the

Figure I.3.4: Single-bladed wind turbine



greatest blade section dimensions with all the installed blade surface area in a single beam. It is normal to shut down (park) wind turbines in very high winds, in order to protect them from damage. This is because they would generally experience much higher blade and tower loads if they continued to operate. The one-bladed design allows unique parking strategies – with the single blade acting as a wind vane upwind or downwind behind the tower – which may minimise storm loading impact. However, there are a number of disadvantages. With a counterweight to balance the rotor statically, there is reduced aerodynamic efficiency and complex dynamics requiring a blade hinge to relieve loads. The designs of Riva Calzoni, MAN, Messerschmidt and others were also of too high a tip speed to be acceptable in the modern European market from an acoustic point of view.

Figure I.3.5: Two-bladed wind turbines of Carter Wind Turbines Ltd



The two-bladed rotor design (Figure I.3.5) is technically on a par with the established three-bladed design. In order to obtain a potentially simpler and more efficient rotor structure with more options for rotor and nacelle erection, it is necessary either to accept higher cyclic loading or to introduce a teeter hinge, which is often complex. The teeter hinge allows the two blades of the rotor to move as a single beam through typically  $\pm 7^\circ$  in an out-of-plane rotation. Allowing this small motion can much relieve loads in the wind turbine system, although some critical loads return when the teeter motion reaches its end limits. The two-bladed rotor is a little less efficient aerodynamically than a three-bladed rotor.

In general, there are small benefits of rotors having increasing number of blades. This relates to minimising losses that take place at the blade tips. These losses are, in aggregate, less for a large number of narrow blade tips than for a few wide ones.

In rotor design, an operating speed or operating speed range is normally selected first, taking into account issues such as acoustic noise emission. With the speed chosen, it then follows that there is an optimum total blade area for maximum rotor efficiency.

The number of blades is, in principle, open, but more blades imply more slender blades for the fixed (optimum) total blade area.

Note also that it is a complete misconception to think that doubling the number of blades would double the power of a rotor. Rather, it would reduce power if the rotor was well designed in the first instance.

It is hard to compare the two- and three-bladed designs on the basis of cost-benefit analysis. It is generally incorrect to suppose that, in two-bladed rotor design, the cost of one of three blades has been saved, as two blades of a two-bladed rotor do not equate with two blades of a three-bladed rotor. Two-bladed rotors generally run at much higher tip speed than three-bladed rotors, so most historical designs would have noise problems. There is, however, no fundamental reason for the higher tip speed, and this should be discounted in an objective technical comparison of the design merits of two versus three blades.

The one-bladed rotor is perhaps more problematic technically, whilst the two-bladed rotor is basically acceptable technically. The decisive factor in eliminating the one-blade rotor design from the commercial market, and in almost eliminating two-bladed design, has been visual impact. The apparently unsteady passage of the blade or blades through a cycle of rotation has often been found to be objectionable.

### **Pitch Versus Stall**

This section discusses the two principal means of limiting rotor power in high operational wind speeds – stall regulation and pitch regulation. Stall-regulated machines require speed regulation and a suitable torque speed characteristic intrinsic in the aerodynamic design of the rotor. As wind speed increases and the rotor speed is held constant, flow angles over the blade sections steepen. The blades become increasingly stalled and this limits power to acceptable levels, without any additional active control. In stall control, an essentially constant speed is achieved through the connection of

the electric generator to the grid. In this respect, the grid behaves like a large flywheel, holding the speed of the turbine nearly constant irrespective of changes in wind speed.

Stall control is a subtle process, both aerodynamically and electrically. In summary, a stall-regulated wind turbine will run at approximately constant speed in high wind without producing excessive power and yet achieve this without any change to the rotor geometry.

The main alternative to stall-regulated operation is pitch regulation. This involves turning the wind turbine blades about their long axis (pitching the blades) to regulate the power extracted by the rotor. In contrast to stall regulation, pitch regulation requires changes of rotor geometry by pitching the blades. This involves an active control system, which senses blade position, measures output power and instructs appropriate changes of blade pitch.

The objective of pitch regulation is similar to stall regulation, namely to regulate output power in high operational wind speeds. A further option, active stall regulation, uses full span pitching blades. However, they are pitched into stall in the opposite direction to the usual fine pitching where the aerofoil sections are rotated leading edge into wind direction. This concept, like the conventional fine pitch solution, uses the pitch system as a primary safety system, but also exploits stall regulation characteristics to have much reduced pitch activity for power limiting.

### **Variable Speed Versus Fixed Speed**

Initially, most wind turbines operated at fixed speed when producing power. In a start-up sequence the rotor may be parked (held stopped), and on release of the brakes would be accelerated by the wind until the required fixed speed was reached. At this point, a connection to the electricity grid would be made and then the grid (through the generator) would hold the speed constant. When the wind speed increased beyond the level at which rated power was generated, power would



be regulated in either of the ways described above, by stall or by pitching the blades.

Subsequently, variable speed operation was introduced. This allowed the rotor and wind speed to be matched, and the rotor could thereby maintain the best flow geometry for maximum efficiency. The rotor could be connected to the grid at low speeds in very light winds and would speed up in proportion to wind speed. As rated power was approached, and certainly after rated power was being produced, the rotor would revert to nearly constant speed operation, with the blades being pitched as necessary to regulate power. The important differences between variable speed operation as employed in modern large wind turbines and the older conventional fixed speed operation are:

- Variable speed in operation below rated power can enable increased energy capture.
- Variable speed capability above rated power (even over quite a small speed range) can substantially relieve loads, ease pitch system duty and much reduce output power variability.

The design issues of pitch versus stall and degree of rotor speed variation are evidently connected. In the 1980s, the classic Danish, three-bladed, fixed speed, stall-regulated design was predominant. Aerodynamicists outside the wind industry (such as for helicopters and gas turbine) were shocked by the idea of using stall. Yet, because of the progressive way in which stall occurs over the wind turbine rotor, it proved to be a thoroughly viable way of operating a wind turbine. It is one of the unique aspects of wind technology.

Active pitch control is the term used to describe a control system in which the blades pitch along their axis like a propeller blade. Superficially, this approach seemed to offer better control than stall regulation, but it emerged through experience that pitch control of a fixed speed wind turbine at operational wind speeds that are a lot higher than the rated wind speed (minimum steady wind speed at which the turbine

can produce its rated output power) could be quite problematic. The reasons for this are complex, but in turbulent (constantly changing) wind conditions, it is demanding to keep adjusting pitch to the most appropriate angle and under high loads, and excessive power variations can result whenever the control system is 'caught out' with the blades in the wrong position.

In view of such difficulties, which were most acute in high operational wind speeds (of say 15–25 m/s), pitch control in conjunction with a rigidly fixed speed became regarded as a 'challenging' combination. Vestas initially solved this challenge by introducing OptiSlip (which allows a certain degree of variable speed using pitch control in power-limiting operations, in the range of 10 per cent speed variation using a high slip induction generator). Suzlon presently use a similar technology, Flexslip, with a maximum slip of 17 per cent. Speed variation helps to regulate power and reduces demand for rapid pitch action.

Variable speed has some attractions, but also brings cost and reliability concerns. It was seen as a way of the future, with expected cost reduction and performance improvements in variable speed drive technology. To some extent these have been realised. However, there was never a clear case for variable speed on economic grounds, with small energy gains being offset by extra costs and also additional losses in the variable speed drive. The current drive towards variable speed in new large wind turbines relates to greater operational flexibility and concerns about the power quality of traditional stall-regulated wind turbines. Two-speed systems emerged during the 1980s and 1990s as a compromise, improving the energy capture and noise emission characteristics of stall-regulated wind turbines. The stall-regulated design remains viable, but variable speed technology offers better output power quality to the grid, and this is now driving the design route of the largest machines. Some experiments are underway with the combination of variable speed and stall regulation, although variable speed combines naturally with pitch regulation. For

reasons related to the methods of power control, an electrical variable speed system allows pitch control to be effective and not overactive.

Another significant impetus to the application of pitch control, and specifically pitch control with independent pitching of each blade, is the acceptance by certification authorities that this allows the rotor to be considered as having two independent braking systems acting on the low speed shaft. Hence, only a parking brake is required for the overall safety of the machine.

Pitch control entered wind turbine technology primarily as a means of power regulation which avoided stall when, from the experience of industries outside wind technology, stall was seen as problematic if not disastrous. However, in combination with variable speed and advanced control strategies, stall offers unique capabilities to limit loads and fatigue in the wind turbine system and is almost universally employed in new large wind turbine designs. The load-limiting capability of the pitch system improves the power to weight ratio of the wind turbine system and compensates effectively for the additional cost and reliability issues involved with pitch systems.

### DESIGN DRIVERS FOR MODERN TECHNOLOGY

The main design drivers for current wind technology are:

- low wind and high wind sites;
- grid compatibility;
- acoustic performance;
- aerodynamic performance;
- visual impact; and
- offshore.

Although only some 1.5 per cent of the world's total installed capacity is currently offshore, the latest developments in wind technology have been much influenced by the offshore market. This means that,

in the new millennium, the technology development focus has been mainly on the most effective ways to make very large turbines. Specific considerations are:

- low mass nacelle arrangements;
- large rotor technology and advanced composite engineering; and
- design for offshore foundations, erection and maintenance.

A recent trend, however, is the return of development interest to new production lines for the size ranges most relevant to the land-based market, from 800 kW up to about 3 MW. Of the other main drivers, larger rotor diameters (in relation to rated output power) have been introduced in order to enhance exploitation of low wind speed sites. Reinforced structures, relatively short towers and smaller rotor diameters in relation to rated power are employed on extremely high wind speed sites.

Grid compatibility issues are inhibiting further development of large wind turbines employing stall regulation. Acoustic performance regulates tip speed for land-based applications and requires careful attention to mechanical and aerodynamic engineering details. Only small improvements in aerodynamic performance are now possible (relative to theoretical limits), but maximising performance without aggravating loads continues to drive aerodynamic design developments. Visual impact constrains design options that may fundamentally be technically viable, for example two-bladed rotors.

### ARCHITECTURE OF A MODERN WIND TURBINE

Many developments and improvements have taken place since the commercialisation of wind technology in the early 1980s, but the basic architecture of the mainstream design has changed very little. Most wind turbines have upwind rotors and are actively yawed to preserve alignment with the wind direction.

The three-bladed rotor proliferates and typically has a separate front bearing, with low speed shaft connected to a gearbox that provides an output speed suitable for the most popular four-pole (or two-pole) generators. This general architecture is shown in Figure I.3.6. Commonly, with the largest wind turbines, the blade pitch will be varied continuously under active control to regulate power in higher operational wind speeds. For future large machines, there appears to be a consensus that pitch regulation will be adopted.

Support structures are most commonly tubular steel towers tapering in some way, both in metal wall thickness and in diameter from tower base to tower top. Concrete towers, concrete bases with steel upper sections, and lattice towers are also used but are much less prevalent. Tower height is rather site-specific and turbines are commonly available with three or more tower height options.

The drive train of Figure I.3.6 shows the rotor attached to a main shaft driving the generator through the gearbox. Within this essentially conventional architecture of multi-stage gearbox and high-speed generator, there are many significant variations in structural support, in rotor bearing systems and in general layout. For example, a distinctive layout (Figure I.3.7) has been developed by Ecotècnia

Figure I.3.7: Ecotècnia 100 nacelle layout



(Alstom), which separates the functions of rotor support and torque transmission to the gearbox and generator. This offers a comfortable environment for the gearbox, resulting in predictable loading and damping of transients, due to its intrinsic flexibility. Among the more innovative of a large variety of bearing arrangements is the large single front bearing arrangement adopted by Vestas in the V90 3 MW design (Figure I.3.8). This contributes to a very compact and lightweight nacelle system.

Whilst rotor technology is set amongst the leading commercial designs and the upwind three-bladed rotor prevails generally, more unconventional trends in nacelle architecture are appearing. The direct drive systems of Enercon are long established, and many direct drive designs based on permanent magnet generator (PMG) technology have appeared in recent years. A number of hybrid systems, such as Multibrid, which employ one or two gearing stages, and multi-pole generators have also appeared. These developments are discussed in 'Technology Trends' below. It is far from clear which of the configurations is the optimum. The effort to minimise capital costs and

Figure I.3.6: Typical nacelle layout of a modern wind turbine



Figure I.3.8: Vestas V90 nacelle layout

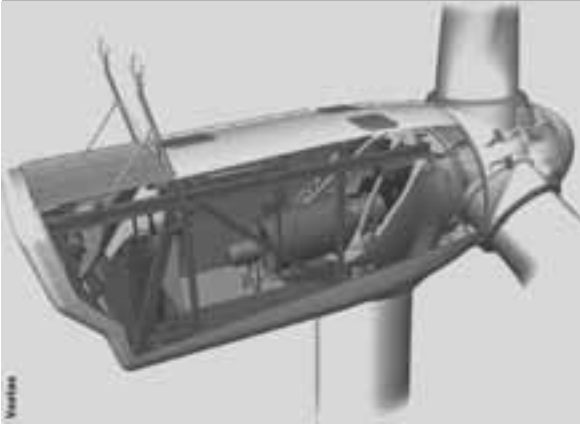

maximise reliability continues – the ultimate goal is to minimise the cost of electricity generated from the wind.

### GROWTH OF WIND TURBINE SIZE

Modern wind technology is available for a range of sites: low and high wind speeds and desert and arctic climates can be accommodated. European wind farms operate with high availability (97 per cent) and are generally well integrated with the environment and accepted by the public.

At the start of the millennium, an ever increasing (in fact mathematically exponential) growth in turbine size with time had been documented by manufacturers, such as Siemens Wind Power (earlier Bonus AS), and was a general industry trend. In the past three or four years, although interest remains in yet larger turbines for the offshore market, there has been a levelling of turbine size at the centre of the main, land-based market and a focus on increased volume supply in the 1.5 to 3 MW range.

The past exponential growth of turbine size was driven by a number of factors. The early small sizes, around 20–60 kW, were very clearly not optimum for

Figure I.3.9: Modern wind technology



system economics. Small wind turbines remain much more expensive per kW installed than large ones, especially if the prime function is to produce grid quality electricity. This is partly because towers need to be higher in proportion to diameter to clear obstacles to wind flow and escape the worst conditions of turbulence and wind shear near the surface. But it is primarily because controls, electrical connection to grid and maintenance are a much higher proportion of the capital value of the system.

Also, utilities have been used to power in much larger unit capacities than the small wind turbines, or even wind farm systems of the 1980s, could provide.

When wind turbines of a few hundred kW became available, these were more cost-effective than the earlier smaller units, being at a size where the worst economic problems of very small turbines were avoided. However, all the systems that larger wind turbines would require were also needed and the larger size was the most cost-effective. It also became apparent that better land utilisation could often be realised with larger wind turbine units, and larger unit sizes were also generally favourable for maintenance cost per kW installed. All these factors, the psychology of 'bigger is better' as a competitive element in manufacturers' marketing and a focus of public research funding programmes on developing larger turbines contributed to the growth of unit size through the 1990s.

Land-based supply is now dominated by turbines in the 1.5 and 2 MW range. However, a recent resurgence in the market for turbines around 800 kW size is interesting, and it remains unclear, for land-based projects, what objectively is the most cost-effective size of wind turbine.

The key factor in maintaining design development into the multi-megawatt range has been the development of an offshore market. For offshore applications, optimum overall economics, even at higher cost per kW in the units themselves, requires larger turbine units to limit the proportionally higher costs of infrastructure (foundations, electricity collection and sub-sea transmission) and lower the number of units to access and maintain per kW of installed capacity.

Figure I.3.10 summarises the history of sizes of leading commercial wind turbines up to the present (2008) and illustrates a few concepts for the largest turbines of the near future. The future challenges in extending the conventional three-bladed concept to size ranges above 5 MW are considerable, and are probably as much economic as engineering issues. REpower, exploiting reserve capacity in design margins, has up-rated its 5 MW wind turbine to 6 MW and

Figure I.3.10: Growth in size of commercial wind turbine designs

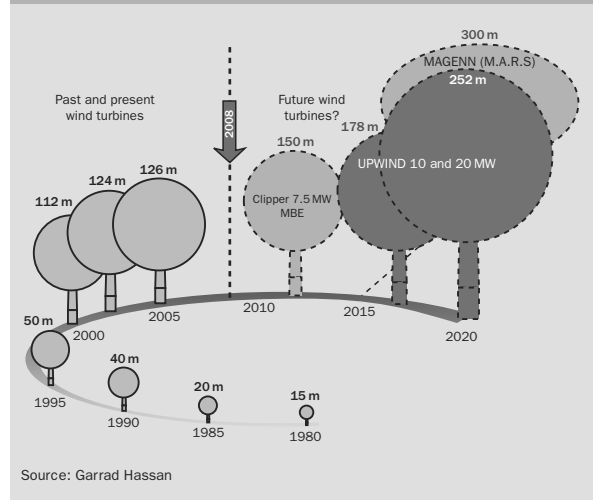

BARD Engineering has announced a similar up-rating of its 5 MW design to 6 MW and later 7 MW. Clipper Windpower has announced a 7.5 MW prototype to be purchased by the UK Crown Estates (an unprecedented type of investment for them), with no specific timeline for development, but suggestions of production by around 2012. The interest in yet larger wind turbines, especially for offshore markets, is reflected in the UpWind project. This major project of the EU 6 Framework Programme addresses a wide range of wind energy issues, including up-scaling, by evaluating the technical and economic issues in developing unit wind turbines of 10 and 20 MW capacity. The Magenn airborne wind energy concept is one of a number of speculative new concepts for large capacity wind energy systems that is reviewed later in the chapter ('Future Innovations').

## LARGE COMMERCIAL WIND TURBINES

The 'top ten' wind turbine manufacturers, as measured by global market share in 2007, and some salient

## 74 WIND ENERGY - THE FACTS - TECHNOLOGY

features of the technology of some of their flagship designs, are listed in Table I.3.1.

### Vestas

Vestas has long been the world's leading supplier of wind turbines. Key volume products are the V80 and V90 series. Vestas technology is generally particularly lightweight. Blades made using high strength composites in the form of prepregs, and innovation in nacelle systems design, has contributed to this characteristic.

According to industry sources, Vestas is developing a new offshore wind turbine model.

### GE Energy

GE is now focusing increasingly on their 2.5 MW 2.5XL series, which entered series production in the summer of 2008. This is seen as the next generation of turbines to succeed the proven 1.5 MW series and be produced at high volumes. It is interesting to note the change in design to a permanent magnet generator with full converter retains a high-speed generator with a multi-stage planetary gear system. Doubly fed induction generator (DFIG) technology has been

challenged recently by more stringent network requirements, the 'fault ride-through' requirement in particular, and adaptations have been made to respond to these issues. The DFIG solution is undoubtedly cheaper in capital cost than systems with full converters. However, the implications for part-load efficiency can make it inferior in cost of energy to efficient systems with PMG and full converter, and the value of capitalised losses should not be underestimated. This may in part be the motivation for GE's change in design route and adoption of a PMG generator in their latest turbine series. Note also that a synchronous PMG can be applied without design hardware modifications in both 50 Hz and 60 Hz network regions. This greatly increases flexibility for international developers operating in multiple wind markets.

### Gamesa Eolica

The latest design from Gamesa Eolica, the Gamesa G10X, a 4.5 MW, 128 m diameter prototype, is presently being developed. Key features of this design include:

- a two-bearing arrangement, integrated with a two-stage planetary type gearbox;

Table I.3.1: Design choices of leading manufacturers

		Share (%)	Model	Drive train	Power rating (kW)	Diameter (m)	Tip speed (m/s)	Power conversion
1	Vestas	22.8	V90	Geared	3000	90	87	Asynchronous
2	GE Energy	16.6	2.5XL	Geared	2500	100	86	PMG converter
3	Gamesa	15.4	G90	Geared	2000	90	90	DFIG
4	Enercon	14.0	E82	Direct	2000	82	84	Synchronous
5	Suzlon	10.5	S88	Geared	2100	88	71	Asynchronous
6	Siemens	7.1	3.6 SWT	Geared	3600	107	73	Asynchronous
7	Acciona	4.4	AW-119/3000	Geared	3000	116	74.7	DFIG
8	Goldwind	4.2	REpower750	Geared	750	48	58	Induction
9	Nordex	3.4	N100	Geared	2500	99.8	78	DFIG
10	Sinovel	3.4	1500 (Windtec)	Geared	1500	70		

Source: Garrad Hassan

Figure I.3.11: Nacelle of the Gamesa G10X 4 MW wind turbine



- a low mass sectional blade (inserts bonded into carbon pultruded profiles are bolted on site);
- a hybrid tower with concrete base section and tubular steel upper section; and
- an attached FlexFit™ crane system that reduces the need for large external cranes.

Gamesa is also using state-of-the-art control and converter technology in this design. The main shaft is integrated into a compact gearbox, limited to two stages and providing a ratio of 37:1. It would appear that their system will have a synchronous generator with fully rated power converter. The nacelle of the G10X is shown in Figure I.3.11. Figure I.3.12 shows presently operational Gamesa G87 2 MW wind turbines in the wind farm at Loma de Almendarache.

### Enercon

Enercon has dominated supply of direct drive turbines (Figure I.3.13). They have favoured wound-rotor generator technology in their designs, although permanent magnet technology is now the choice of most manufacturers developing new direct drive designs. A direct drive generator, with a wound field rotor is more complex, requiring excitation power to be

Figure I.3.12: Gamesa G87 (2 MW) at Loma de Almendarache



passed to the rotor, but it benefits from additional controllability.

Enercon has perhaps the aerodynamic design that gives most consideration to flow around the hub area, with their blade profile smoothly integrated with the hub cover surface in the fine pitch position. Their latest designs achieve a very high rotor aerodynamic efficiency, which may be due both to the management of flow in the hub region and tip winglets (blade tip ends curved out of the rotor plane), which can inhibit tip loss effects.

Enercon has quite diverse renewable energy interests, which include commercially available wind desalination and wind-diesel systems. In addition, it

Figure I.3.13: Enercon E-82



has involvement in hydro energy systems and Flettner rotors for ship propulsion.

### Suzlon Energy and REpower

Suzlon produces wind turbines in a range from 350 kW to 2.1 MW. It has developed its technology through acquisitions in the wind energy market and is targeting a major share in the US market.

Recent additions to the range include the S52, a 600 kW turbine for low wind speed Indian sites, and S82, a 1.50 MW turbine. The S52 employs a hydraulic torque converter that can allow up to 16 per cent slip, thus providing some of the benefits of variable speed operation.

In 2007, after a five-month takeover battle with the French state-owned nuclear company Areva, Suzlon took a controlling stake in REpower, with 87 per cent of the German wind company's voting rights.

REpower, which had previously acquired the blade supplier Abeking & Rasmussen, continues to expand its manufacturing facilities in Germany and also rotor blade production in Portugal. The company cooperates with Abeking & Rasmussen ROTEC, manufacturing rotor blades at Bremerhaven in a joint venture, PowerBlades GmbH.

### Siemens Wind Power

Siemens Wind Power (formerly Bonus) is among the few companies that are becoming increasingly successful in the offshore wind energy market. Its 3.6 MW SWT turbines of 107 m diameter (Figure I.3.14) are now figuring prominently in offshore projects. Senior management in Siemens has indicated the end of a trend of exponential growth in turbine size (considering, year by year, the turbine design at the centre of their commercial supply). The stabilisation of turbine size has been a significant trend in the past three or four years and, although there is much discussion of larger machines and developments on the drawing board and a few prototypes, there is some evidence that, at least for land-based projects, turbine size is approaching a ceiling.

Figure I.3.14: Siemens Wind Power (Bonus)





### Acciona Energy

In a four-year period, Acciona has become the seventh ranked world manufacturer in terms of MW supplied. The company presently has four factories, two located in Spain and one each in the US and China. In total, this amounts to a production capacity of 2625 MW a year.

Acciona's latest design is a new 3 MW wind turbine to be commercially available in 2009 and delivered to projects in 2010. The new turbine is designed for different wind classes (IEC Ia, IEC IIa and IEC IIIa). It will be supplied with a concrete tower of 100 or 120 m hub height and will have three rotor diameter options of 100, 109 and 116 m, depending on the specific site characteristics. The rotor swept area for the 116 m diameter is 10,568 m<sup>2</sup>, the largest in the market of any 3 MW wind turbine, which will suit lower wind speed sites.

Electricity is generated at medium voltage (12 kV), aiming to reduce production losses and transformer costs. The main shaft is installed on a double frame to reduce loads on the gearbox and extend its working life. The AW-3000 operates at variable speed, with independent blade pitch systems.

In North America, the AW-3000 will be manufactured at the company's US-based plant, located in West Branch, Iowa. The AW-1500 (Figure I.3.15) and AW-3000 machines will be built concurrently. The present production capacity of 675 MW/year is planned to be increased to 850 MW/year.

### Goldwind

Goldwind is a Chinese company in the wind industry providing technology manufactured under licences from European suppliers. Goldwind first licensed REpower's 48 kW to 750 kW turbine technology in 2002, and then acquired a licence in 2003 from Vensys Energiesysteme GmbH (Saarbrücken, Germany) for the Vensys 62 1.2 MW turbine. When Vensys developed a low wind speed version, with a larger 64m diameter rotor that increased output to 1.5 MW,

Figure I.3.15: Acciona new AW1500



Goldwind also acquired the licence for this turbine and is currently working with Vensys to produce 2.0 MW and 2.5 W turbines. Goldwind won a contract to supply 33 wind turbines (1.5 MW Vensys 77 systems) for the 2008 Olympic Games in Beijing. The company operates plants in Xinjiang, Guangdong, Zhejiang and Hebei Provinces and is building plants in Beijing (Figure I.3.16) and Inner Mongolia. In 2008, Goldwind signed a six-year contract with LM Glasfiber (Lunderskov, Denmark) to supply blades for Vensys 70 and 77 turbines (Figure I.3.17) and develop blades for Goldwind's

Figure I.3.16: Manufacturing at Goldwind



Figure I.3.17: Vensys



Figure I.3.18: Sinovel 1.5 MW wind turbines



next generation of 2 MW and larger turbines at LM's factory in Tianjin.

### Nordex

Nordex is developing new control techniques and has a condition monitoring system, which monitors component wear, also incorporating ice sensors and an automatic fire extinguishing system.

### Sinovel

In March 2007, the AMSC (American Superconductor Corporation) signed a multi-million dollar contract with Sinovel Wind, under which 3 and 5 MW wind turbines would be developed. Sinovel is continuing to manufacture and deploy the 1.5 MW wind turbines (Figure I.3.18) it began producing in 2005. The 1.5 MW wind turbines also utilise core electrical components produced by AMSC.

Earlier in 2007, AMSC had acquired the Austrian company Windtec to open opportunities for them in the wind business. Windtec has an interesting history, originating as Floda, a company that developed groundbreaking variable speed wind turbines in the latter part of the 1980s. Based in Klagenfurt, Austria,

Windtec now designs a variety of wind turbine systems and licenses the designs to third parties.

In June 2008, AMSC received a further \$450 million order from Sinovel for core electrical components for 1.5 MW wind turbines. The contract calls for shipments to begin in January 2009 and increase in amount year by year until the contract's completion in December 2011. According to AMSC, the core electrical components covered under this contract will be used to support more than 10 GW of wind power capacity, nearly double China's total wind power installed base at the end of 2007.

## Technology Trends

### LARGER DIAMETERS

Figure I.3.19 shows trends by year of the typical largest turbine sizes targeted for mainstream commercial production. There were megawatt turbines in the 1980s, but almost all were research prototypes. An exception was the Howden 55 m 1 MW design (erected at Richborough in the UK), a production prototype, which was not replicated due to Howden withdrawing from the wind business in 1988. Although there is much more active consideration of larger designs than indicated

Figure I.3.19: Turbine diameter growth with time

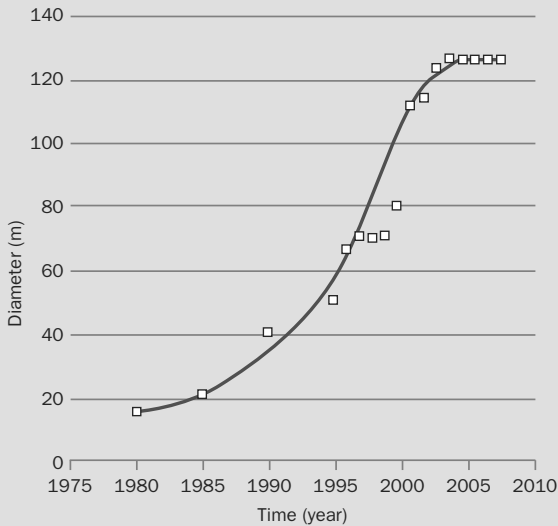

Source: Garrad Hassan

in Figure I.3.19, there has been a definite pause in the appearance of any larger turbines since 2004.

The world's largest wind turbine is currently the Enercon E-126 (Figure I.3.20) installed in Emden, Germany, in February 2008. The E-126 is a development from the E-112, which had been up-rated to 6 MW. The new E-126 has a rating of 6 MW and may be up-rated to 7 MW. The Enercon E-126 extends the design of the E-112 and, although this design represents an increase in rated power of the world's largest wind turbines, the physical size of the rotor is similar to the REpower 5 MW design. Thus there has been no significant increase in rotor size since 2004.

### TIP SPEED TRENDS

There is no fundamental reason for tip speed to change with scale. However, for turbines on land, restrictions on acoustic noise emission increase as a power function to the tip speed, and so often limit how fast the tip can go. This was especially the case when turbines

Figure I.3.20 Enercon E-126



predominantly operated in fixed speed mode. Variable speed wind turbines have greater operational flexibility and can benefit from a high rated speed, but still operate at reduced speed (at night, for example) in noise-sensitive areas. Higher tip speed has the advantage that, for a given output power, the torque on the drive train is reduced and therefore the drive train mass and cost also decrease.

Offshore, there is a clear potential benefit in higher tip speeds, and less constraint on acoustic emission levels. However, with increasing tip speed, blade solidity decreases (in an optimised rotor design), and blades will tend to become more flexible. This can be beneficial for system loads but problematic for maintaining the preferred upwind attitude, with adequate tower clearance of the blade tips in

extreme loading conditions. Listed data on design tip speed (Figure I.3.21) shows an increase with scale, albeit with great scatter in the data. It is evident that the present ceiling is around 90 m/s, but also that, to restrict tower top mass, very large offshore turbines will not adopt design tip speeds much below 80 m/s.

## PITCH VERSUS STALL

There has been an enduring debate in the wind industry about the merits of pitch versus stall regulation. These alternatives were discussed in the earlier section on 'The technical challenge of a unique technology'.

Until the advent of MW-scale wind turbines in the mid-1990s, stall regulation predominated, but pitch regulation is now the favoured option for the largest machines (Figure I.3.22). There are now about four times as many pitch-regulated turbine designs on the market than stall-regulated versions. The dominance of pitch-regulated turbines will be still greater in terms of numbers of machines installed. The prevalence of pitch regulation is due to a combination of factors.

Overall costs are quite similar for each design type, but pitch regulation offers potentially better output power quality (this has been perhaps the most significant factor in the German market), and pitch regulation with independent operation of each pitch actuator allows the rotor to be regarded as having two independent braking systems for certification purposes.

There has been some concern about stall-induced vibrations (vibrations which occur as the blade enters stall), being particularly problematic for the largest machines. However, there has in fact been little evidence of these vibrations occurring on a large scale. There were specific problems of edgewise vibrations of stall-regulated rotor blades (or in the nacelle, tuned to the edgewise rotor whirling modes experienced by the nacelle), associated with loss of aerodynamic damping in deep stall, but this was addressed by introducing dampers in the rotor blades.

## SPEED VARIATION

Operation at variable speed offers the possibility of increased 'grid friendliness', load reduction and

Figure I.3.21: Tip speed trends

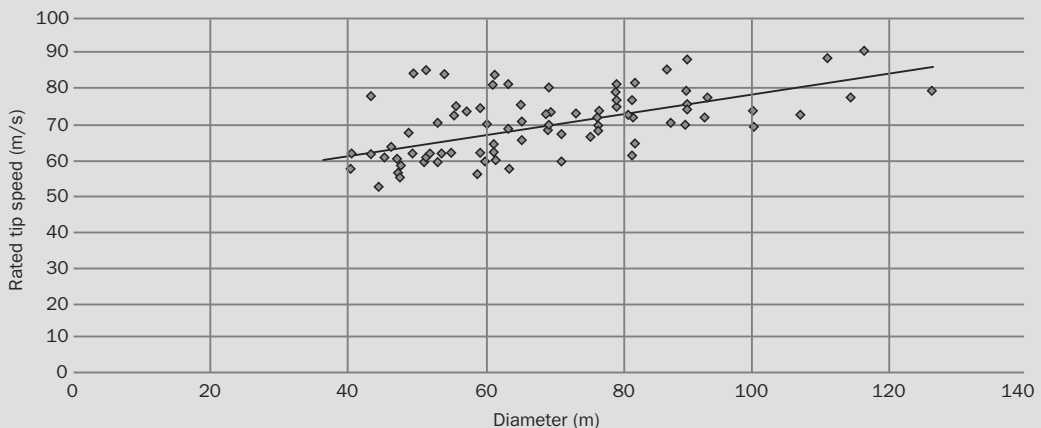
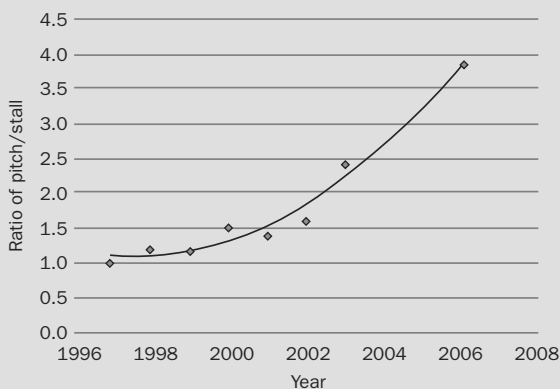

Figure I.3.22: Ratio of pitch-regulated to stall-regulated designs of  $\geq 1$  MW rating



Source: Garrad Hassan

some minor energy benefits. Among wind turbines over 1 MW, out of 95 distinct models from 29 different manufacturers, 9 were fixed speed, 14 had two-speed systems and 72 employed variable speed. This shows that it is almost mandatory for MW-scale turbines to have some degree of speed variation and that continuously variable speed is the predominant choice.

Variable speed operation is realised in many ways, each differing in significant details. Direct drive systems have a natural capability for a very wide speed range, although even there some restriction on minimum speed may reduce the cost of power electronics. The 'conventional' variable speed concept, using a geared drive train, connects the generator to the network through a power electronic converter and enables systems that may have wide or narrow speed ranges. The electrical energy is generated at variable frequency – a frequency related to the rotational speed of the rotor – and then converted, by the converter or inverter (both power electronic devices), to the frequency of the grid. There are several possible configurations, based on both synchronous and induction generators.

The most popular system is currently the doubly fed induction generator (DFIG), also called the wound rotor induction generator (WRIG). This provides almost all the benefits of full-range variable speed drives, but only a proportion, perhaps one-third, of the power passes through the converter. The power converter thus has approximately a third of the size, cost and losses of a conventional variable speed drive. In this concept, the stator of the electrical machine is connected directly to the network, and the rotor circuit is connected via the power converter. This is a modern version of the classical Kramer or Scherbius system. The DFIG has a more limited speed range than the conventional variable speed drive (approximately 1.5–2:1, compared to 2.5:1 or more). This speed range, however, is sufficient to provide the benefits listed above. The conventional option of a power converter, with the same rating as the generator, is unlikely to compete with the DFIG until the cost of power electronic converters falls substantially and the efficiency improves. There is evidence that this point may have been reached, with some manufacturers moving over to fully rated converters. In this respect, the potential for improved efficiency in avoiding the DFIG route may come to outweigh cost differentials. Also, some of the benefit of a DFIG system has been eroded by more stringent network requirements impacting on DFIG system cost.

The so-called 'squirrel-cage induction generator' may be used with a fully rated converted, as in some Siemens designs. Other novel generator configurations have been proposed for wind turbine applications, including the switched reluctance machine (SR, also known as variable reluctance). All rely on full-size power converters, and are therefore also at a disadvantage relative to the DFIG. The DFIG configuration used at present requires slip-rings to transfer power to and from the rotor circuit. There is an alternative method, which in effect transfers the rotor power magnetically, called the brushless doubly fed induction generator (BDIG), which avoids the use of slip-rings.

## 82 WIND ENERGY - THE FACTS - TECHNOLOGY

However, at least one generator manufacturer has concluded that such machines are inherently larger and more expensive than the slip-ring option. There is no commercial turbine using the BDIG. As the experience of WRIG with slip-rings is good in wind turbines, this remains the preferred option. Slip-ring maintenance intervals of six months are achieved, and may be stretched to yearly.

### DRIVE TRAIN TRENDS

#### Bearing Arrangements

A wide variety of rotor bearing arrangements has been tried within the context of the established conventional drive train, with multiple stage gearbox and high-speed generator. The basic requirement is to support rotor thrust and weight, whilst communicating only torque to the gearbox. Early highly modular drive trains, with well-separated twin rotor bearings and a flexible connection to the gearbox, could achieve this. However, especially with the increase in turbine size, there has been increasing interest in systems that reduce the weight and cost of the overall system. A large single slew-ring type bearing has been employed in the V90 as the main rotor bearing. Two- and three-point bearing systems are adopted in many designs, with no clear sign of consolidation of design choices. The general trend towards more integrated nacelle systems means that bearing designs are highly interactive with the complete systems concept. This is substantially true for the conventional drive train and even more so for direct drive and related concepts.

#### Direct Drive and Permanent Magnet Generators (PMGs)

There has been a significant trend towards innovative drive train systems, and direct drive or hybrid systems with reduced gearing figure in many new designs.

Table I.3.2 shows direct drive turbines commercially available in the wind energy market. Enercon has long pioneered direct drive and is the only company with a large market share delivering this technology.

Design trends are now predominantly towards PMGs and the design struggle is to realise the potentially better efficiency and reliability of a direct drive system without cost or weight penalties. It may be noted that the trend towards PMG technology is much wider than in the context of direct drive alone. Clipper Windpower (after research into systems with multiple induction generators), Northern Power Systems (after initially adopting a wound rotor direct drive design) and GE Energy, in their recent 2.5XL series, have all adopted PMG systems.

Table I.3.2: Direct drive wind turbines

Turbine	Diameter (m)	Power (kW)
ENERCON E-112	114.0	4500
ENERCON E-70 E4	71.0	2300
Harakosan (Zephyros) Z72	70.0	2000
ENERCON E-66	70.0	1800
MTorres TWT 1650/78	78.0	1650
MTorres TWT 1650/70	70.0	1650
VENSYS 70	70.0	1500
VENSYS 77	77.0	1500
Leitwind LTW 77	77.0	1350
VENSYS 64	64.0	1200
VENSYS 62	62.0	1200
Leitwind LTW 61	61.0	1200
ENERCON E-58	58.0	1000
ENERCON E-48	48.0	800
Jeumont J53	53.0	750
Jeumont J48	48.0	750
ENERCON E-33	33.4	330
Subaru 22/100 (FUJI)	22.0	100
Northern Power NW 100/19	19.1	100
Unison U50 750 kW	50.0	750

The Unison U50 750 kW wind turbine (Figure I.3.23) is among recent designs emerging in East Asia that endorse the direct drive PMG concept. The PMG is overhung downwind of the tower, balancing the rotor weight and giving the nacelle its characteristic shape.

### Hybrid

Designs with one or two stages of gearing, but not involving high-speed two- or four-pole generators, are classified here as 'hybrid'. Such designs from Clipper Windpower, WinWinD and Multibrid are reviewed in 'Alternative drive train configurations'. These designs also maintain the trend towards PMG technology.

### Fully Rated Converters

The DFIG route was discussed in 'Speed variation'. It has been predominant and will probably endure for some time in the high volume markets of Asia, for example, but is being challenged elsewhere by more stringent network requirements, the efficiency benefits of PMG technology and advances in power converter technology.

### HUB HEIGHT

When wind turbines were designed exclusively for use on land, a clear average trend of hub height, increasing linearly in proportion to diameter, had been evident, although there is always very large scatter in such data, since most manufacturers will offer a range of tower heights with any given turbine model, to suit varying site conditions.

Figure I.3.24 shows that the trend in hub height with scale is now less than in proportion to diameter. This trend has resulted, quite naturally, from the largest machines being for offshore, where there is reduced wind shear. Offshore, the economic penalties of increased foundation loads and tower cost will typically outweigh any small energy gains from a much increased hub height.

### ROTOR AND NACELLE MASS

Rotor mass trends are always complicated by quite different material solutions, choice of aerofoils and design tip speed, all of which can impact very directly on the solidity (effectively surface area) and mass of a blade. Table I.3.3 shows the blade mass of very large wind turbines.

The introduction into Enercon's E-126 design of a jointed blade with a steel spar on the inner blade is a clear example of where blade technology is radically different from most other large blades.

Figure I.3.23: Unison U50



Figure I.3.24: Hub height trends

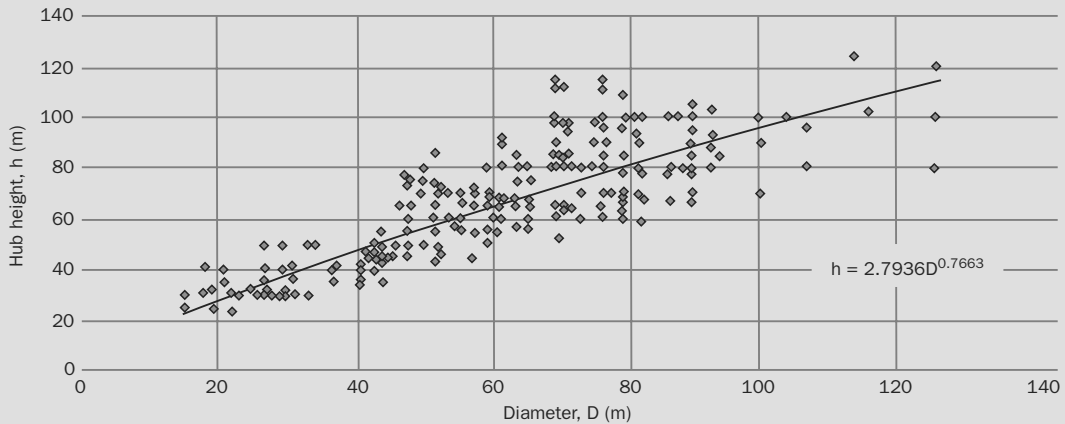

Source: Garrad Hassan

BARD has also made an interesting decision in blade design, eliminating carbon-fibre reinforcement from their blades. Their blade design preserves a very large chord on the inboard section. On most blade designs, maximum chord is usually limited to less than the aerodynamic optimum, in order to facilitate manufacturing, handling and transport. BARD will directly ship their blades from a dockside manufacturing site, avoiding the land transport issues with very large blades. LM also avoids carbon reinforcement in their latest LM 61.5 blade.

For any given design style, nacelle mass is very much determined by turbine torque rating, which

scales as the cube of diameter. This implies that, with consistent design at the same level of technology development, the scaling exponent of nacelle mass will be cubic. Considering data from various public sources, it appears (Figure I.3.25) that nacelle mass scales approximately as the square of diameter. It is clear, however, that the largest turbines deviate substantially from the trend line and, considering only modern large turbines above 80m, the exponent is seen to be approximately cubic (Figure I.3.26).

Manufacturers are continually introducing new concepts in drive train layout, structure and components to reduce mass and cost, but avoiding the cubic scaling (or worse when gravity loads begin to dominate), increases in system mass and cost linked to up-scaling, a concept which is currently being studied in depth in the UpWind project. This project includes an exploration of the technical and economic feasibility of 10 and 20 MW wind turbines.

Table I.3.3: Blade mass of very large wind turbines

	Diameter (m)	Blade mass (tonnes)	Normalised mass* (tonnes)
BARD VM	122	26	28
E-112	114	20	24
M5000	116	17	20
REpower 5M	126	18	18

**Note:** \*The 'normalised mass' is an approximate adjustment to bring all the designs to a common point of reference relative to any one design (in this case REpower 5M), taking account of different diameters and different relations between rated power and diameter.

## TRANSPORT AND INSTALLATION

Erection of wind farms and systems for handling ever larger components has progressed since the



Figure I.3.25: Scaling of wind turbine nacelle system mass

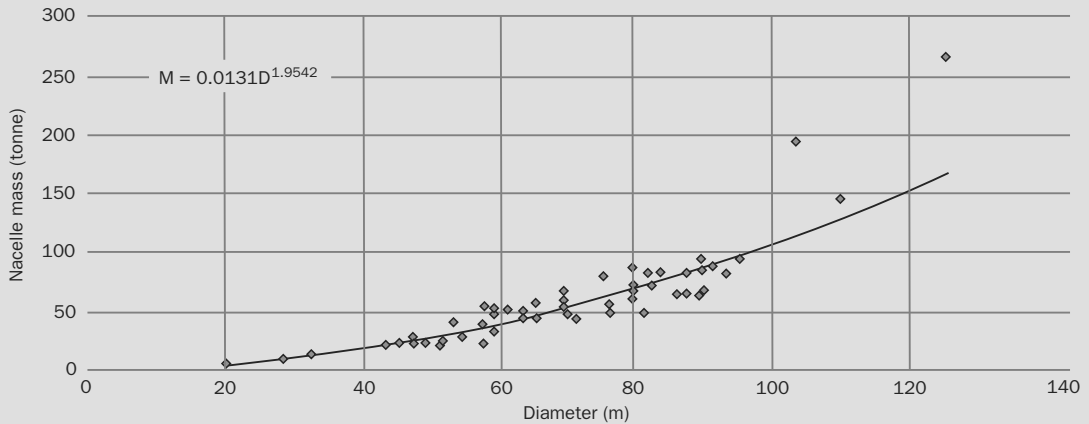

Source: Garrad Hassan

early commercial projects of the 1980s. For a period up to the mid-1990s, the allowable mass of components to be lifted to hub height was determined by available cranes. Subsequently, there has been a shift, indicative of the maturity and growth of the wind industry, where crane manufacturers are producing designs specially suited to wind farm installation.

Often complete rotors are lifted onto nacelles. Sometimes hub and blades are lifted individually.

The Enercon E-126 exploits a jointed blade design to facilitate transport, handling and erection of the rotor components. The blade joints are made up in the air. Thus rotor erection practice moved through size ranges where complete rotors were crane lifted, to size ranges where hub and blades were lifted

Figure I.3.26: Scaling of nacelle system mass (turbines >80 m diameter)

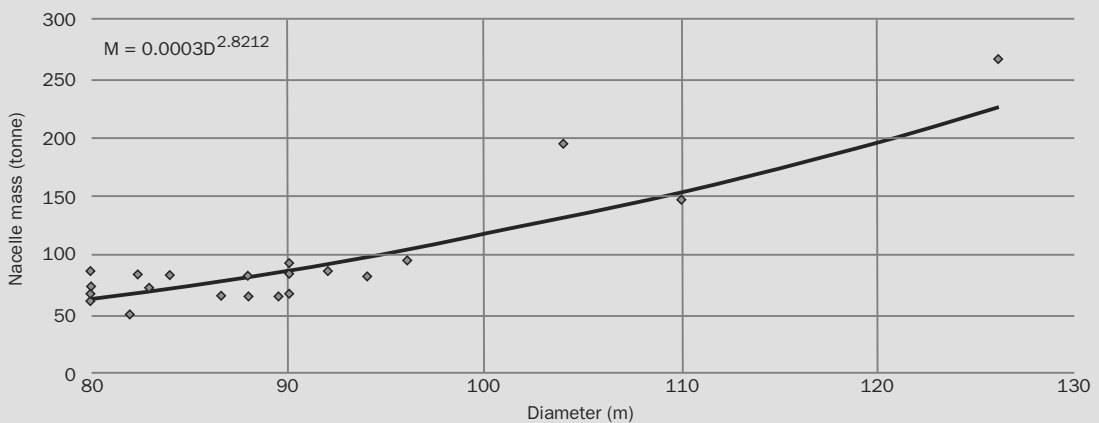

Source: Garrad Hassan

Figure I.3.27: Erection of Nordex wind turbines



individually, and now to the E-126, where blade parts are lifted individually.

A wind farm of Nordex N100 wind turbines (the largest Nordex wind generators in the US) was erected (Figure I.3.27) over a five mile long ridge south of Wadena, Minnesota.

This project made first use of the new 2007 DEMAG CC2500-1, a 550 ton crawler, a crane with 126m of main boom with jib combination to 168m. Transport of the CC2250-1 with maximum boom and counterweights requires 36 truckloads. This assembly approach for a wind farm involving whole rotor lifts of 100m diameter rotors contrasts strongly with the erection strategy of the E-126.

## Current Developments

### ROTOR BLADE DEVELOPMENT

#### Large Blade Design

Development in materials for rotor blades is ongoing. Testing ranging from characterisation of constituent materials, through blade sub-components to whole blades is vital for the integrity of new designs.

Figure I.3.28: LM Glasfiber blade test (LM 61.5 m blade for 126 m rotor diameter)



As the wind industry has matured, proof testing, ultimate load testing and fatigue testing of new rotor blade designs has become the norm. Figure I.3.28 shows blade testing at LM Glasfiber, which has long been the world's largest independent blade supplier. The commitment of LM Glasfiber to blade development for wind turbines is shown by a recent investment in their own specially designed wind tunnel, which can provide tunnel speeds up to 105 m/s and test an airfoil with 0.90 m chord at Reynolds number up to 6 million.

The handling and transport issues with very large blades have caused some manufacturers to revisit ideas for jointed blades.

The world's largest wind turbine, the Enercon E-126, adopts a jointed blade design. In the E-126 blade, an essentially standard outer blade section with a conventional blade root attachment is bolted to a steel inner blade spar. The trailing edge of the inner blade is a separate composite structure.

Gamesa has also developed a jointed blade design for the G10X.

Enercon has been pushing the limits in maximum attainable aerodynamic performance of a horizontal axis wind turbine rotor, achieving a measured rotor power performance coefficient in excess of 0.5. It may be noted that its recent designs take great care to manage the flow regime in the region of the hub and also employ winglets, which are suggested by research at Risø DTU to reduce power loss associated with the blade tip effect.

### Pitch Systems

The Genesys 600 kW direct drive wind turbine, on which the Vensys designs are based, employed almost wear-free toothed belts in the pitch drives, instead of the more common hydraulic cylinders or geared electric pitch motors. One key advantage claimed for this innovation is insensitivity to shock loads, since such impact forces are distributed over multiple meshing teeth pairs. A second advantage is that the drive system does not require grease lubrication and is almost maintenance free. Toothed belts are widely used in industrial and automotive applications. Vensys have maintained this feature in their present designs.

## ALTERNATIVE DRIVE TRAIN CONFIGURATIONS

Whilst the rotor configuration of large wind turbines as three composite blades in upwind attitude with full span pitch control has consolidated in the past ten years, there is increasing variety in current drive train arrangements. A few of the considerable variety of layout and bearing options of the drive train, with gearbox and conventional high-speed generator, were discussed in 'Architecture of a modern wind turbine'. Other drive train options can be classified as direct drive (gearless) or as hybrid, in other words with some level of

gearing (usually one or two stages) and one or more multi-pole generators.

### Direct Drive

The motivation for direct drive is to simplify the nacelle systems, increase reliability, increase efficiency and avoid gearbox issues. A general trend towards direct drive systems has been evident for some years, although there are considerable challenges in producing technology that is lighter or more cost-effective than the conventional geared drive trains. Although these developments continue, direct drive turbines have not, as yet, had a sizeable market share. The exception is Enercon, which has long supplied direct drive generators employing a synchronous generator and having an electrical rotor with windings rather than permanent magnets. Most other direct drive designs are based on PMG technology, using high-strength Neodymium magnets. In July 2008, Siemens installed the first of two new 3.6 MW direct drive turbines to assess whether direct drive technology is competitive with geared machines for large turbines. The two turbines, which have a rotor diameter of 107 m, use a synchronous generator and permanent magnets.

MTorres started wind industry activities in 1999, leading to development of the TWT-1500, a 1500 kW wind turbine with a multi-pole synchronous generator. The nacelle layout of the MTorres wind turbine is indicated in the schematic diagram above (Figure I.3.29).

The Netherlands manufacturer Lagerwey supplied small wind turbines for a number of years and, at a later stage, developed wind turbines of 52, 58 and 72 m diameter with direct drive generators. The LW 52 and LW 58 were wound rotor synchronous machines like Enercon's. Lagerwey then sought to develop a larger 1.5 MW direct drive turbine with Zephyros, the Zephyros LW 72. The first installation, at a site in The Netherlands, used a permanent magnet generator

Figure I.3.29: M-Torres wind turbine design



design and generation at medium voltage (3 to 4 kV). Subsequently, Zephyros separated from Lagerwey and was acquired by Harakosan.

Another notable development in direct drive has come from the Vensys designs, which derive from the Genesys 600 kW prototype of 1997, developed at Saarbrücken University. Vensys turbines may see increasing market presence through the interests of the Chinese developer Goldwind.

Northern Power Systems (NPS) developed the Northwind 100 wind turbine. Several hundred of their 100 kW turbines have been installed, often in remote locations. Their direct drive generator originally employed a salient pole wound-rotor technology, but, in line with most new direct drive designs, they have since developed a permanent magnet generator design and an innovative power converter design (Figure I.3.30).

### Hybrid Systems

Hybrid systems are a middle route between the conventional solution with three stages of gearing at megawatt scale and direct drive solutions, which

Figure I.3.30: Northern Power Systems 100 kW drive train concept



generally demand rather a large diameter generator. The intention is to have a simpler and more reliable gearbox, with a generator of comparable size, leading to a dimensionally balanced and compact drive train.

This design route was launched in the Multibrick concept licensed by Aerodyn. The inventor, George Bohmeke, has pursued that technology with the Finnish company WinWind.

A characteristic of the system is the more balanced geometry of gearbox and generator, leading to a compact arrangement. The nacelle need not extend much aft of tower centre-line (Figure I.3.31), as is generally appropriate for offshore machines, unless it will be accommodating electrical power equipment, such as the converter and transformer.

The structural economy achieved with such an integrated design is well illustrated in Figure I.3.31, with the main nacelle structure tending towards an open shell structure, a broadly logical result since, rather like the hub, it also connects circular interfaces (yaw bearing and main rotor bearing) that have substantial angular spacing.

Figure I.3.31: WinWind 3 MW



Source: WinWind

Clipper Windpower (Figure I.3.32) manufactures 2.5 MW wind turbines, with a hybrid drive train of very distinctive design. After initial research into systems with multiple induction generators, Clipper developed a system with an innovative gearbox with outputs to

four PMGs. As with other hybrids, this again leads to a very compact drive train.

Prokon Nord Energiesysteme GmbH, based in Leer, acquired the previous Multibrid company in 2003. The prototype M5000 (Figure I.3.33) was installed in Bremerhaven and commissioned in 2005. The Multibrid technology was subsequently acquired by Areva in June 2008.

Distinctive features of the M5000 include a highly compact integrated slow rotating drive system,

Figure I.3.32: Clipper Windpower Liberty wind turbine with Multi-PMG system



Figure I.3.33: Multibrid 5 MW wind turbine



comprising a single main bearing (no main shaft), a single-stage gearbox and a medium speed PMG (58–147 rpm). With a tower-head mass of 310 tonnes, the M5000 is apparently the lightest wind turbine rated around 5 MW.

### **Other Drive Train Developments**

Hydraulic components have figured in drive train design for some time in motors, brakes, fluid couplings or torque limiting systems. Hydraulic drives comprising pump(s) and motor(s) for main power transmission were employed in the unsuccessful Bendix 3 MW prototype of the early 1980s, but this design route was not pursued. Key problems were inadequate capacity, efficiency, reliability and life of existing commercial hydraulic components – the lack of components specifically designed for the needs of efficient wind power generation.

The Scottish company Artemis has addressed this and has developed a high-efficiency, long-life, ring cam pump, with electronically controlled poppet valves to suit wind turbine applications. Ring cam pumps are very rugged and reliable. Those, for example, made by the Scottish supplier MacTaggart Scott are welded into the hulls of submarines for life. Development work which will subsequently consider wind power transmission systems in the 5 to 10 MW range is progressing with funding assistance from the UK Carbon Trust. Artemis claims a 20 per cent mass reduction in nacelle systems can result, commenting that the power density of hydraulic machines is at least three times higher than the most advanced electric motor.

Another recent use of fluidic systems is in the Voith transmission system, adopted by De Wind (now owned by Composites Technology Inc.). This is essentially a way of realising a variable speed in the gearbox, thereby allowing direct connection of a synchronous generator to the output and hence avoiding the need for an electrical power converter.

The Voith WinDrive system uses a hydrodynamic torque converter to provide the variable speed relationship between the output shafts. WinDrive is essentially a mechanical solution to variable speed operation, based on a torque converter in combination with a planetary gear system. As a fluid machine, the torque converter is well matched to the wind turbine rotor and, via the fluid in the converter, the system decouples the input and output shafts absorbing input torque spikes and providing damping of vibrations.

With WinDrive, added mechanical complexity and cost in the gear system is compensated by elimination of the cost, mass and losses of an electrical power converter. The damping and compliance, intrinsic in the hydrodynamic coupling, ensures that a synchronous generator can be used. The Voith technology is long established in industrial drives, but the wind power application presents new challenges, especially in fatigue life and efficiency, which Voith have been addressing.

### **CONTROLLER CAPABILITIES**

In the early days, wind turbine controllers had simple sequential control tasks to perform: start-up, controlled shutdown, and the monitoring of temperatures and other status indications from important components. At the academic level, it was realised early on that more advanced control could reduce the mechanical loads on the turbine, and thereby allow mass to be reduced. This has now been implemented to some extent in some turbine designs, principally by controlling individual blade pitch and generator torque (via the variable-speed electronic power converter). Additional inputs, such as nacelle acceleration, are required. The control algorithm then has a complex optimisation task to perform, and the controller principles and algorithms are considered highly confidential by turbine manufacturers.

This trend is likely to continue as experience is gained. The computation required is not great compared

to control tasks in other industries. Therefore, the rate of development is likely to be set by the rate at which experience is gained with prototypes and the rate at which models of the turbines and their environments can be developed and validated.

Further progress is expected, as means are developed to provide further reliable measurements of mechanical loads: measurement of blade loads through optical fibre strain gauges appears to be a hopeful development.

## NETWORK OPERATOR REQUIREMENTS

As noted in previous sections, the technical requirements of network operators are becoming more onerous. The principal areas are:

- the ability to stay connected and perhaps also contribute to system stability during disturbances on the electricity system (including ‘fault ride-through’);
- the ability to control reactive power generation/consumption in order to contribute towards control of voltage; and
- a general aim for the wind farm (not necessarily each wind turbine) to respond similarly to conventional thermal generation, where possible.

These issues are considered in more detail in Part II. However, the net effect is to increase the arguments for variable speed operation, and in particular for concepts using a fully rated electronic converter between the generator and the network. Concepts with mechanical or hydraulic variable speed operation and a synchronous generator, connected directly to the network, are also suitable.

It should be noted that some of the required functions require fast response and communications from the wind farm SCADA (supervisory control and data acquisition) system.

It is also feasible to meet the requirements for reactive power control and for fault ride-through by

using fixed-speed or DFIG wind turbines, and additional power electronic converters (commonly called statcoms or static VAR compensators). This can be done by a single converter at the wind farm point of connection to the grid, or by smaller units added to each turbine.

## TESTING, STANDARDISATION AND CERTIFICATION

Standardisation is largely achieved through the IEC 61400 series of standards specifically for the wind industry, and their national or European equivalents. Standardisation work is driven by industry requirements, but requires consensus, and therefore takes considerable time. A process of gradual change and development is expected, rather than any radical changes.

Testing of major components, such as blades, is expected to develop, driven both by standards and by manufacturers. Certification of turbine designs by independent bodies is now well established.

## Future Innovations

### NEW SYSTEM CONCEPTS

Technology development in the largest unit sizes of conventional wind turbines has been particularly stimulated by the emerging offshore market, and many of the most innovative wind energy systems proposed in recent years target that market. System concepts, such as floating turbines that are intrinsically for offshore, are reviewed in Chapter 1.5. Systems involving innovations that may operate from land or offshore are presented below. Some of these systems may be the way of the future; some will undoubtedly disappear from the scene. At the very least, they illustrate the huge stimulus for creative engineering which has arisen from the challenges in

harnessing renewable energy sources and from the establishment of wind energy technology in the power industry.

### Electrostatic Generator

An electrostatic generator is being investigated in the High Voltage Laboratory at TU Delft. It is presently at the laboratory feasibility stage, being tested at milliwatt scale. The considerable attraction is to have a system with few mechanical parts. It is seen as being potentially suitable for buildings, due to minimal noise and vibration, or for offshore, on account of simplicity and the potential to be highly reliable.

In the EWICON design, charged droplets are released, and transported and dispersed by the wind to create DC current in collector wires. One key issue with this system is the level of power consumption used in charging the droplets. Up-scaling to useful power capacities from micro laboratory size is thought to benefit performance but has yet to be demonstrated.

### AIRBORNE TURBINES

Airborne turbine concepts have appeared, at least in patent documents, for many years, and such concepts are presently generating increased interest. The designs are broadly classified as:

- systems supported by balloon buoyancy;
- kites (lifting aerofoils); and
- tethered auto gyros.

Some systems combine these features. Key issues are:

- controllability, in the case of kites;
- general problems associated with maintaining the systems in flight for long periods; and
- reliable power transmission to land/sea level without heavy drag-down from the power cables or tethers.

Just as limits on land-based sites and better offshore resources have justified the extension of wind technology offshore, much is made of the increased wind energy density at higher altitudes and reduced energy collection area per MW of capacity, as compensation for the obvious challenges of airborne technology.

The Kite Gen concept (Figure I.3.34) is to access wind altitudes of 800 to 1000 m using power kites in the form of semi-rigid, automatically piloted, efficient aerofoils. All generating equipment is ground-based, and high-strength lines transmit the traction of the kites and control their position. Compared to a rotor, the figure-of-eight path swept by the kite can be beneficial for energy capture, as the inner parts of a conventional wind turbine rotor blade travel at comparatively low speeds through some of the swept area.

In the early 1990s, the Oxford-based inventor Colin Jack patented airborne wind energy ideas, based on the autogyro principle, where some of the lift of the rotor is used to support its weight. This was prompted by the realisation that a balloon capable of supporting the weight of a wind turbine rotor in power producing mode requires much more buoyancy than one able to support the dead weight in calm conditions. This arises

Figure I.3.34: Kite Gen





Figure I.3.35: Sky Windpower flying electric generator

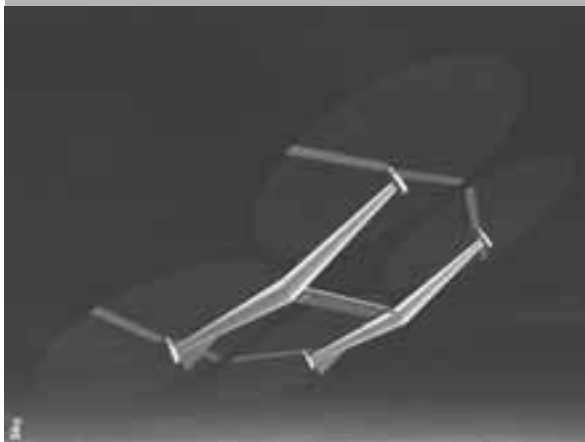

from the 'drag-down' effect of rotor thrust when the turbine is operating. A recent concept, using auto gyro rotors to be self-supporting as well as generating, is illustrated in Figure I.3.35.

In November 2007, Google announced a strategic initiative to develop electricity from renewable energy sources and, in particular, are known to be providing R&D funding for Makani Power to develop innovative airborne technology. As yet, no details of the concept are available.

The Magenn Air Rotor System (MARS) is an airborne tethered horizontal axis wind turbine system, with its rotor in the form of a helium balloon. Generation is at an altitude of around 300m, with power transmission down the tether cable. The generators are at each end of the rotor (Figure I.3.36), with a direct output power connection to the twin cables. Outboard of the generators at each end of the rotor are wind vane stabilisers in the

Figure I.3.36: Magenn



form of conical wheels. The Magnus effect associated with the rotor rotation also provides additional lift, which stabilises the rotor position, causing it to pull up overhead rather than drift downwind on its tether.

### MAGLEV

Maglev is an innovative vertical axis turbine concept. Construction began on a large production site for Maglev wind turbines in central China in November 2007. According to a press release, Zhongke Hengyuan Energy Technology has invested 400 million yuan in building this facility, which will produce Maglev wind turbines with capacities ranging from 400 to 5000 kW.

Using magnetic levitation, the blades of the turbine are suspended on an air cushion, and the energy extracted by linear generators with minimal friction losses. The major advantage of Maglev is claimed to be that it reduces maintenance costs and increases the lifespan of the generator.



## I.4 WIND FARM DESIGN

### Introduction

Previous chapters have discussed wind turbine technology and the wind resource. This chapter presents a brief summary of the design of a wind farm as a whole. The chapter is based on onshore wind farms, though many of the topics are also relevant for offshore. Offshore wind farms are covered in Chapter I.5. Environmental factors that affect wind farm design are discussed in this chapter. Further environmental issues are covered in detail in Part V.

### Factors Affecting Turbine Location

Once a site has been identified and the decision has been taken to invest in its development, the wind farm design process begins. The fundamental aim is to maximise energy production, minimise capital cost and operating costs, and stay within the constraints imposed by the site. As the constraints and costs are all subject to some level of uncertainty, the optimisation process also seeks to minimise risk. The first task is to define the constraints on the development:

- maximum installed capacity (due to grid connection or power purchase agreement terms);
- site boundary;
- 'set back' – distances from roads, dwellings, overhead lines, ownership boundaries and so on;
- environmental constraints;
- location of noise-sensitive dwellings, if any, and assessment criteria;
- location of visually-sensitive viewpoints, if any, and assessment criteria;
- location of dwellings that may be affected by 'shadow flicker' (flickering shadows cast by rotating blades) when the sun is in particular directions, and assessment criteria;
- turbine minimum spacings, as defined by the turbine supplier (these are affected by turbulence, in particular); and

- constraints associated with communications signals, for example microwave link corridors or radar.

These constraints may change as discussions and negotiations with various parties progress, so this is inevitably an iterative process.

When the likely constraints are known, a preliminary design of the wind farm can be produced. This will allow the size of the development to be established. As a rough guide, the installed capacity of the wind farm is likely to be of the order of 12 MW per km<sup>2</sup>, unless there are major restrictions that affect the efficient use of the available land.

For the purpose of defining the preliminary layout, it is necessary to define approximately what sizes of turbine are under consideration for the development, as the installed capacity that can be achieved with different sizes of turbine may vary significantly. The selection of a specific turbine model is often best left to the more detailed design phase, when the commercial terms of potential turbine suppliers are known. Therefore at this stage it is either necessary to use a 'generic' turbine design, defined in terms of a range of rotor diameters and a range of hub heights, or alternatively to proceed on the basis of two or three layouts, each based on specific wind turbines.

The preliminary layout may show that the available wind speed measurements on the site do not adequately cover all the intended turbine locations. In this case it will be necessary to consider installing additional anemometry equipment. The preliminary layout can then be used for discussions with the relevant authorities and affected parties. This is an iterative process, and it is common for the layout to be altered at this stage.

The factors most likely to affect turbine location are:

- optimisation of energy production;
- visual influence;
- noise; and
- turbine loads.

## OPTIMISATION OF ENERGY PRODUCTION

Once the wind farm constraints are defined, the layout of the wind farm can be optimised. This process is also called wind farm ‘micro-siting’. As noted above, the aim of such a process is to maximise the energy production of the wind farm whilst minimising the infrastructure and operating costs. For most projects, the economics are substantially more sensitive to changes in energy production than infrastructure costs. It is therefore appropriate to use energy production as the dominant layout design parameter.

The detailed design of the wind farm is facilitated by the use of wind farm design tools (WFDTs). There are several that are commercially available, and others that are research tools. Once an appropriate analysis of the wind regime at the site has been undertaken, a model is set up that can be used to design the layout, predict the energy production of the wind farm, and address issues such as visual influence and noise.

For large wind farms it is often difficult to manually derive the most productive layout. For such sites a computational optimisation using a WFDT may result in substantial gains in predicted energy production. Even a 1 per cent gain in energy production from improved micro-siting is worthwhile, as it may be achieved at no increase in capital cost. The computational optimisation process will usually involve many thousands of iterations and can include noise and visual constraints. WFDTs conveniently allow many permutations of wind farm size, turbine type, hub height and layout to be considered quickly and efficiently, increasing the likelihood that an optimal project will result. Financial models may be linked to the tool so that returns from different options can be directly calculated, further streamlining the development decision-making process.

An example screen dump from a typical WFDT is presented in Figure I.4.1. The darker shaded areas represent the areas of highest wind speed. The turbines

are represented by the small markers with a number underneath. The spacing constraint is illustrated by the ellipses (this constraint is discussed in the turbine loads section).

## VISUAL INFLUENCE

‘Visual influence’ is the term used for the visibility of the wind turbines from the surrounding area.

In many countries the visual influence of a wind farm on the landscape is an important issue, especially in regions with high population density. The use of computational design tools allows the zone of visual influence (ZVI), or visibility footprint, to be calculated to identify from where the wind farm will be visible. It is usually necessary to agree a number of cases with the permitting authorities or other interested parties, such as:

- locations from which 50 per cent of turbine hubs can be seen;
- locations from which at least one hub can be seen; and
- locations from which at least one blade tip can be seen.

Figure I.4.2 shows an example ZVI for a wind farm, generated using a WFDT. The variation in colour represents the proportion of the wind farm that is visible from viewpoints anywhere in the wind farm vicinity.

Such maps tend to exaggerate the actual visual effect of the wind farm, as they do not clearly indicate the effect of distance on visual appearance. They are also difficult for non-specialists to interpret. Therefore it is also common to generate ‘visualisations’ of the appearance of the wind farm from defined viewpoints. These can take the form of ‘wireframe’ representations of the topography. With more work, photomontages can be produced in which the wind turbines are superimposed upon photographs taken from the defined viewpoints.

Figure I.4.1: Example wind speed map from a WFDT

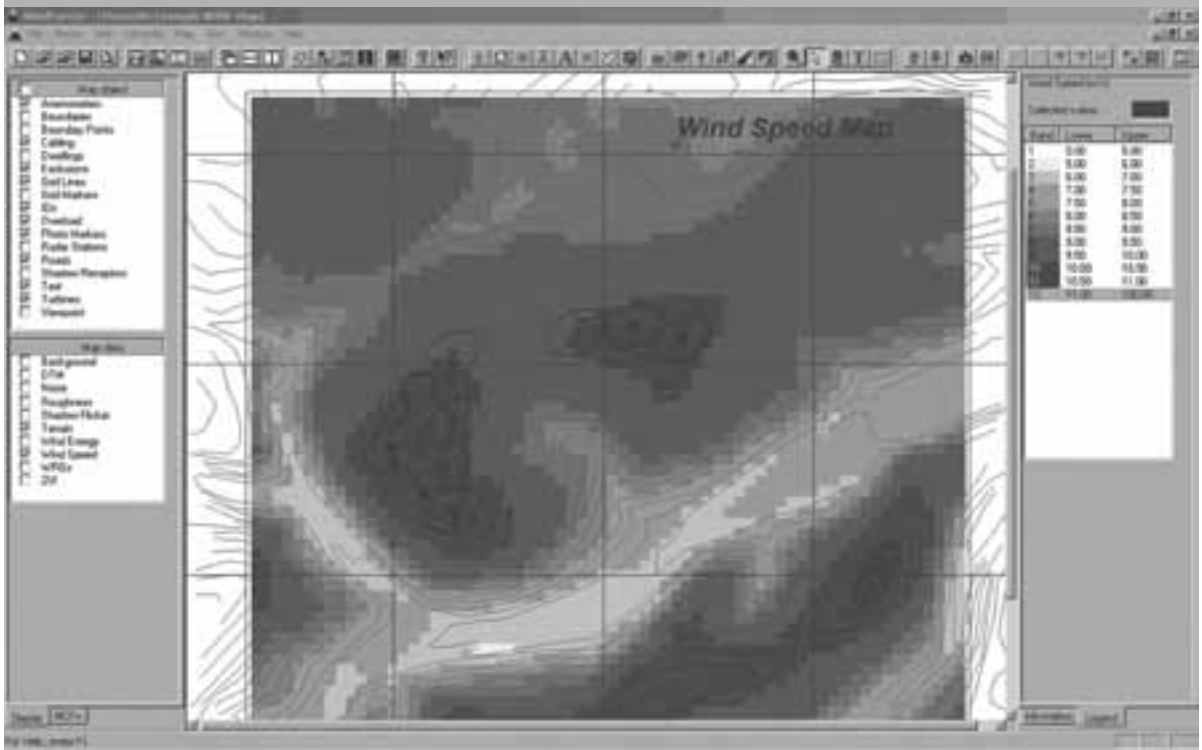

Source: Garrad Hassan

Figure I.4.3 shows an example wireframe representation of a wind farm generated using a WFDT. Figure I.4.4 shows the same image after rendering software has been applied and Figure I.4.5 shows the same image as a photomontage.

Other factors also affect the visual appearance of a wind farm. Larger turbines rotate more slowly than smaller ones, and a wind farm of fewer larger turbines is usually preferable to a wind farm of many smaller ones. In some surroundings, a regular area or straight line may be preferable compared to an irregular layout.

## NOISE

In densely populated countries, noise can sometimes be a limiting factor for the generating capacity that

can be installed on any particular site. The noise produced by operating turbines has been significantly reduced in recent years by turbine manufacturers, but is still a constraint. This is for two main reasons:

1. Unlike most other generating technologies, wind turbines are often located in rural areas, where background noise levels can be very low, especially overnight. In fact the critical times are when wind speed is at the lower end of the turbine operating range, because then the wind-induced background noise is lowest.
2. The main noise sources (blade tips, the trailing edge of the outer part of the blade, the gearbox and generator) are elevated, and so are not screened by topography or obstacles.

Figure I.4.2: A wind farm ZVI generated using a WFDT

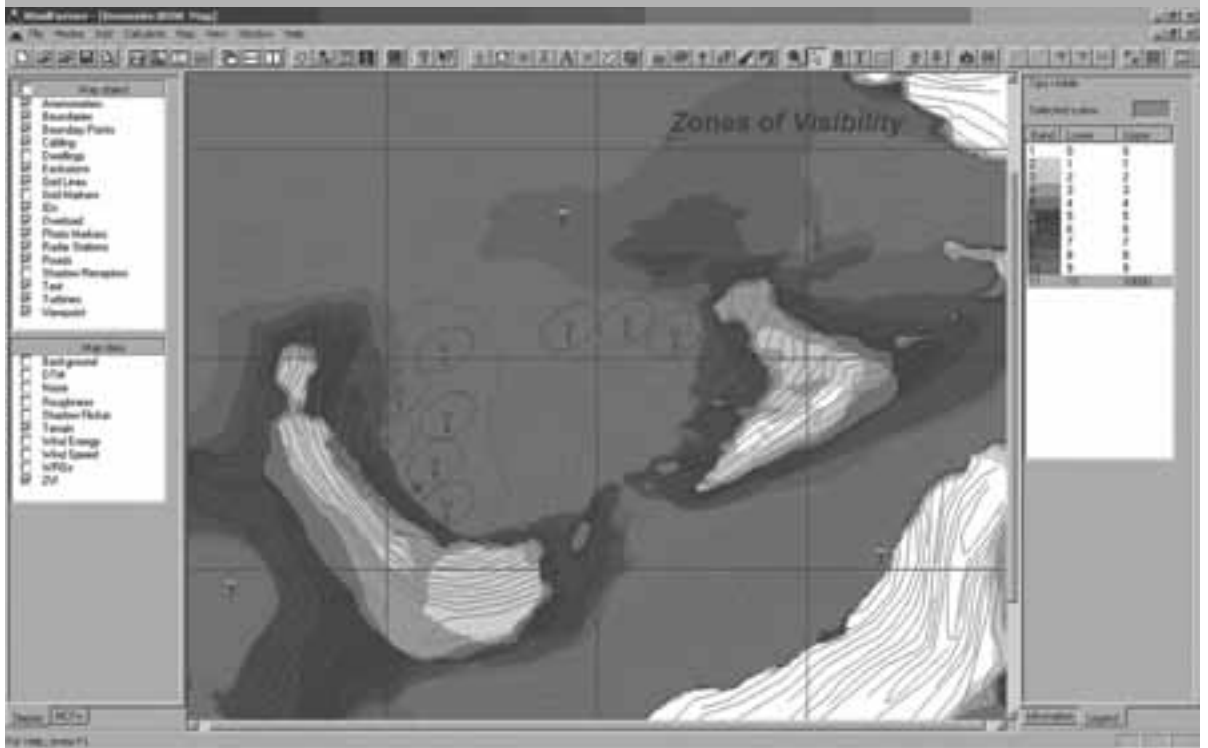

Source: Garrad Hassan

Figure I.4.3: Wireframe generated using a WFDT

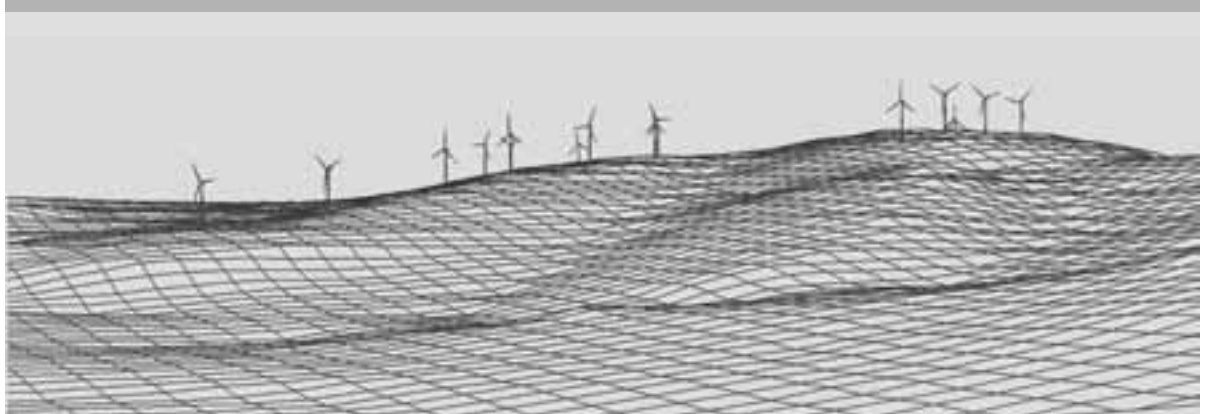

Source: Garrad Hassan

Figure I.4.4: Rendered wireframe generated using a WFDT



Turbine manufacturers may provide noise characteristic certificates, based on measurements by independent test organisations to agreed standards. The internationally recognised standard that is typically referred to is 'Wind turbine generator systems: Acoustic noise measurement techniques' (IEC 61400 Part 11 of 2003).

Standard techniques, taking into account standard noise propagation models, are used to calculate the expected noise levels at critical locations, which are usually the nearest dwellings. The results are then compared with the acceptable levels, which are often defined in national legislation. An example of a 'noise map' that can be generated by a WFDT is shown in Figure I.4.6. The noise contours shown represent the modelled noise at any point in the vicinity of the wind farm.

The internationally recognised standard for such calculations is 'Acoustics – Attenuation of sound during propagation outdoors; Part 2: General method of calculation' (ISO 9613-2).

Sometimes the permitting authorities will require the project to conform to noise limits, with penalties if it can be shown that the project does not comply. In turn the turbine manufacturer could provide a warranty for the noise produced by the turbines. The warranty may be backed up by agreed measurement techniques in case it is necessary to undertake noise tests on one or more turbines.

## **TURBINE LOADS**

A key element of the layout design is the minimum turbine spacing used. In order to ensure that the turbines

Figure I.4.5: Photomontage generated using a WFDT



are not being used outside their design conditions, the minimum acceptable turbine spacing should be obtained from the turbine supplier and adhered to.

The appropriate spacing for turbines is strongly dependent on the nature of the terrain and the wind rose for a site. If turbines are spaced closer than five rotor diameters (5D) in a frequent wind direction, it is likely that unacceptably high wake losses will result. For areas with predominantly unidirectional wind roses, such as the San Geronio Pass in California, or bidirectional wind roses, such as Galicia in Spain, greater distances between turbines in the prevailing wind direction and tighter spacing perpendicular to the prevailing wind direction will prove to be more productive.

Tight spacing means that turbines are more affected by turbulence from the wakes of upstream turbines. This will create high mechanical loads and requires

approval by the turbine supplier if warranty arrangements are not to be affected.

Separately from the issue of turbine spacing, turbine loads are also affected by:

- 'Natural' turbulence caused by obstructions, topography, surface roughness and thermal effects; and
- Extreme winds.

Defining reliable values for these parameters, for all turbine locations on the site, may be difficult. Lack of knowledge is likely to lead to conservative assumptions and conservative design.

Within the wind industry there is an expectation that all commercial wind turbines will be subject to independent certification in accordance with established standards or rules. A project-specific verification of the suitability of the certification for the proposed site should be carried out, taking into

Figure I.4.6: A wind farm noise map generated using a WFDT

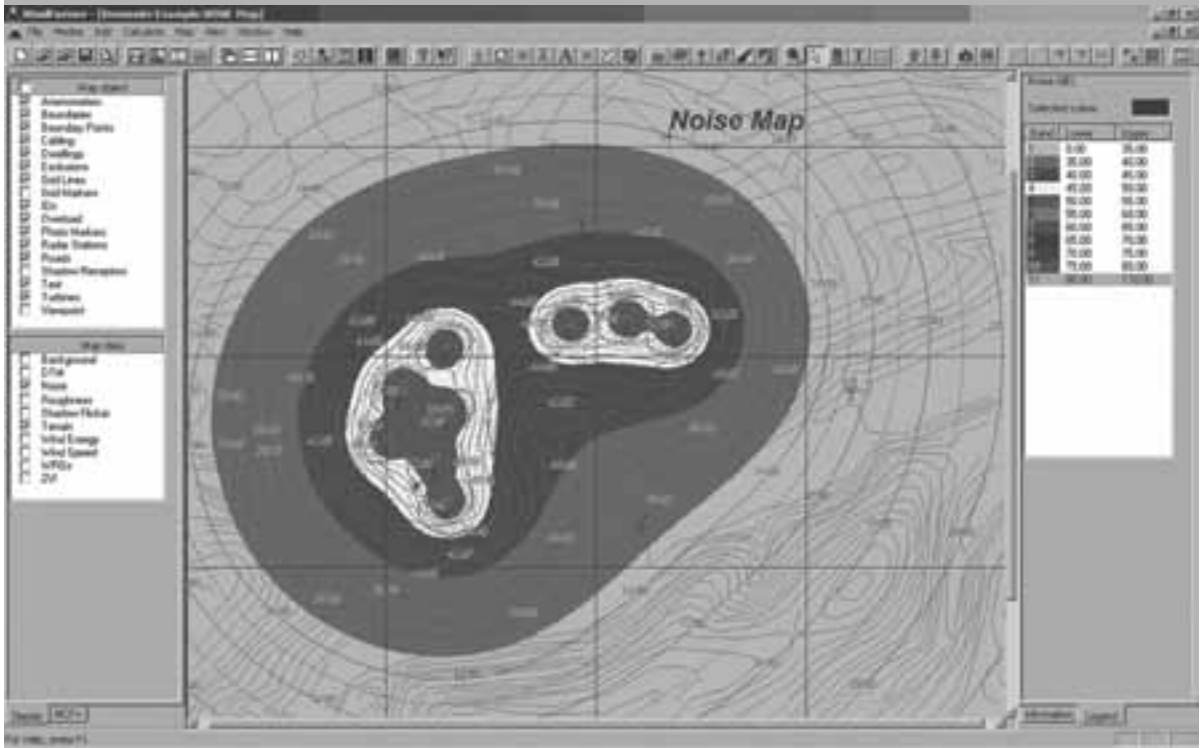

Source: Garrad Hassan

account the turbine design specifications and the expected climatic conditions of the site.

## Infrastructure

The wind farm infrastructure consists of:

- Civil works:
  - roads and drainage;
  - wind turbine foundations;
  - met mast foundations (and occasionally also the met masts); and
  - buildings housing electrical switchgear, SCADA central equipment, and possibly spares and maintenance facilities.
- Electrical works:
  - equipment at the point of connection (POC), whether owned by the wind farm or by the electricity network operator;
  - underground cable networks and/or overhead lines, forming radial ‘feeder’ circuits to strings of wind turbines;
  - electrical switchgear for protection and disconnection of the feeder circuits;
  - transformers and switchgear associated with individual turbines (although this is now commonly located within the turbine and is supplied by the turbine supplier);
  - reactive compensation equipment, if necessary; and
  - earth (grounding) electrodes and systems.



- Supervisory control and data acquisition (SCADA) system:
  - central computer;
  - signal cables to each turbine and met mast;
  - wind speed and other meteorological transducers on met masts; and
  - electrical transducers at or close to the POC.
- The civil works present significant risks to the project costs and programme. It is not unknown for major delays and cost overruns to be caused by poor understanding of ground conditions, or the difficulties of working on sites that, by definition, are exposed to the weather and may have difficult access.
- The major electrical items (transformers, switch-gear) have long lead times. At the time of writing, a large HV/MV power transformer may have a lead time of several years.
- The grid connection works may present a significant risk to the programme. It is likely that works will need to be undertaken by the electricity network operator, and the programme for these works is effectively out of the control of the wind farm developer. It is very unusual for electricity network operators to accept liability for any delay.

The civil and electrical works, often referred to as the 'balance of plant' (BOP), are often designed and installed by a contractor or contractors separate from the turbine supplier. The turbine supplier usually provides the SCADA system.

As discussed above, the major influence on the economic success of a wind farm is the energy production, which is principally determined by the wind regime at the chosen site, the wind farm layout and the choice of wind turbine. However, the wind farm infrastructure is also significant, for the following reasons:

- The infrastructure constitutes a significant part of the overall project cost. A typical cost breakdown is given in Figure I.4.7.

## CIVIL WORKS

The foundations must be adequate to support the turbine under extreme loads. Normally the design load condition for the foundations is the extreme, 'once in 50 years' wind speed. In Europe this wind speed is characterised by the 'three-second gust'. This is a site-specific parameter, which will normally be determined as part of the wind speed measurements and energy production assessment for the site. For most sites this will lie between 45 and 70 m/s. At the lower end of this range it is likely that the maximum operational loads will be higher than the loads generated by the extreme gust and will therefore govern the foundation design.

The first step towards the proper design of the foundations is therefore the specification of a load. The turbine supplier will normally provide a complete specification of the foundation loads as part of a tender package. As the turbine will typically be provided with reference to a generic certification class (see page 94), these loads may also be defined with reference to the generic classes, rather than site-specific load cases.

Figure I.4.7: Typical cost breakdown for an onshore wind farm

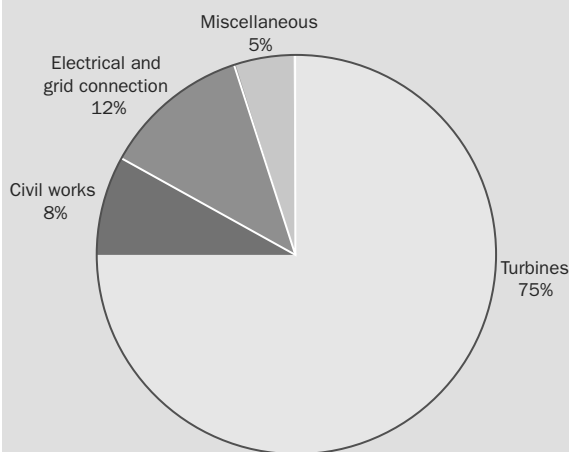

Source: Garrad Hassan

Although extremely important, the foundation design process is a relatively simple civil engineering task. A typical foundation will be perhaps 13 m across a hexagonal form and might be 1–2 m deep. It will be made from reinforced concrete cast into an excavated hole. The construction time for such a foundation, from beginning to end, can easily be less than a week.

The site roads fall well within normal civil engineering practice, provided the nature of the terrain and the weather are adequately dealt with.

For wind farms sited on peat or bogs, it is necessary to ensure that the roads, foundations and drainage do not adversely affect the hydrology of the peat.

The wind farm may also need civil works for a control building to house electrical switchgear, the SCADA central computer, welfare facilities for maintenance staff and spare parts. There may also be an outdoor electricity substation, which requires foundations for transformers, switchgear and other equipment. None of this should present unusual difficulties.

For upland sites, it is often beneficial to locate the control building and substation in a sheltered location. This also reduces visual impact.

## **ELECTRICAL WORKS**

The turbines are interconnected by a medium voltage (MV) electrical network, in the range 10 to 35 kV. In most cases this network consists of underground cables, but in some locations and some countries overhead lines on wooden poles are adopted. This is cheaper but creates greater visual influence. Overhead wooden pole lines can also restrict the movement and use of cranes.

The turbine generator voltage is normally classed as 'low', in other words below 1000 V, and is often 690 V. Some larger turbines use a higher generator voltage, around 3 kV, but this is not high enough for economical direct interconnection to other turbines. Therefore, it is necessary for each turbine to have a transformer to step up to MV, with associated MV switchgear. This

equipment can be located outside the base of each turbine. In some countries these are termed 'padmount transformers'. Depending on the permitting authorities and local electricity legislation, it may be necessary to enclose the equipment within GRP or concrete enclosures. These can be installed over the transformers, or supplied as prefabricated units complete with transformers and switchgear.

However, many turbines now include a transformer as part of the turbine supply. In these cases the terminal voltage of the turbine will be at MV, in the range 10 to 35 kV, and can connect directly to the MV wind farm network without the need for any external equipment.

The MV electrical network takes the power to a central point (or several points, for a large wind farm). A typical layout is shown in Figure I.4.8. In this case the central point is also a transformer substation, where the voltage is stepped up again to high voltage (HV, typically 100 to 150 kV) for connection to the existing electricity network. For small wind farms (up to approximately 30 MW), connection to the local MV network may be possible, in which case no substation transformers are necessary.

The MV electrical network consists of radial 'feeders'. Unlike industrial power networks, there is no economic justification for providing ring arrangements. Therefore a fault in a cable or at a turbine transformer will result in all turbines on that feeder being disconnected by switchgear at the substation. If the fault takes considerable time to repair, it may be possible to reconfigure the feeder to allow all turbines between the substation and the fault to be reconnected.

Figure I.4.8 shows two possible locations for the POC. Definitions of the POC vary from country to country (and are variously called delivery point, point of interconnection or similar), but the definitions are similar: it is the point at which responsibility for ownership and operation of the electrical system passes from the wind farm to the electricity network operator. More complex division of responsibilities is possible (for example, the wind farm developer may build and install

Figure I.4.8: A typical electrical layout

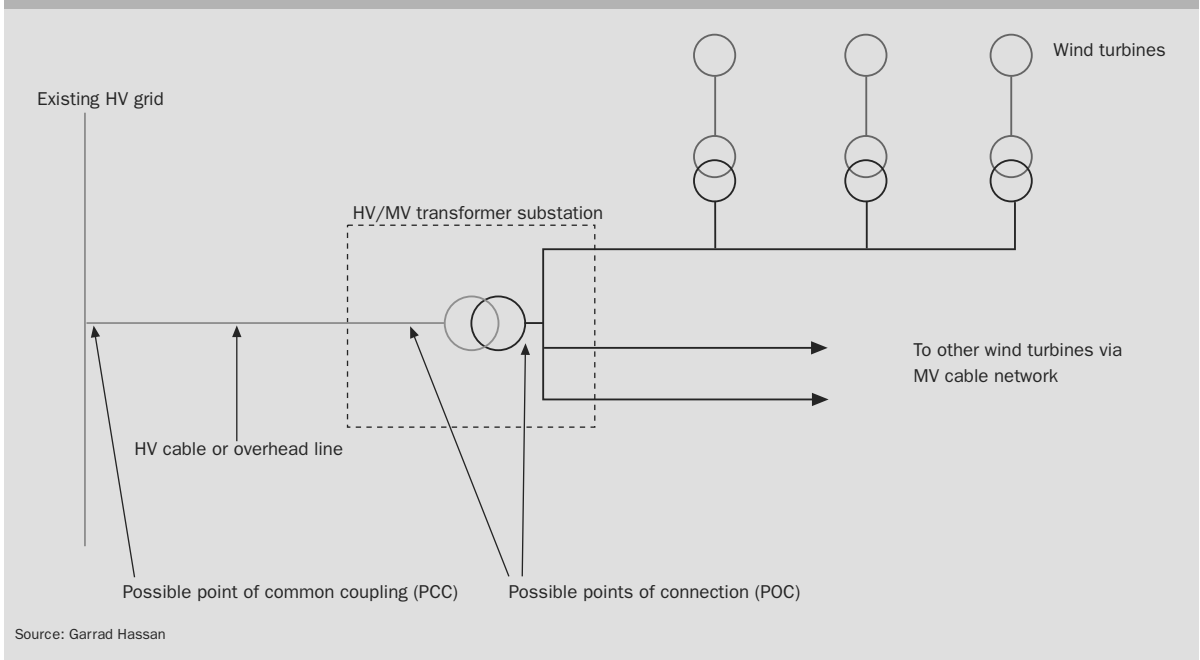

equipment, which then is taken over by the network operator), but this is unusual.

The revenue meters for the wind farm will usually be located at or close to the POC. In some cases, where the POC is at HV, the meters may be located on the MV system to save costs. In this case it is usual to agree correction factors to account for electrical losses in the HV/MV transformer.

Figure I.4.8 also shows a possible location of the 'point of common coupling' (PCC). This is the point at which other customers are (or could be) connected. It is therefore the point at which the effect of the wind farm on the electricity network should be determined. These effects include voltage step changes, voltage flicker and harmonic currents. Grid issues are discussed in detail in Part II. Often the PCC coincides with the POC.

The design requirements for the wind farm electrical system can be categorised as follows:

- It must meet local electrical safety requirements and be capable of being operated safely.

- It should achieve an optimum balance between capital cost, operating costs (principally the electrical losses) and reliability.
- It must ensure that the wind farm satisfies the technical requirements of the electricity network operator.
- It must ensure that the electrical requirements of the turbines are met.

The technical requirements of the electricity network operator are set out in the connection agreement, or a 'grid code' or similar document. This is discussed further in Part II.

## SCADA AND INSTRUMENTS

A vital element of the wind farm is the SCADA system. This system acts as a 'nerve centre' for the project. It connects the individual turbines, the substation and meteorological stations to a central computer. This

computer and the associated communication system allow the operator to supervise the behaviour of all the wind turbines and also the wind farm as a whole. It keeps a record on a ten-minute basis of all the activity, and allows the operator to determine what corrective action, if any, needs to be taken. It also records energy output, availability and error signals, which acts as a basis for any warranty calculations and claims. The SCADA system also has to implement any requirements in the connection agreement to control reactive power production, to contribute to network voltage or frequency control, or to limit power output in response to instructions from the network operator.

The SCADA computer communicates with the turbines via a communications network, which almost always uses optical fibres. Often the fibre-optic cables are installed by the electrical contractor, then tested and terminated by the SCADA supplier.

The SCADA system is usually provided by the turbine supplier, for contractual simplicity. There is also a market for SCADA systems from independent suppliers. The major advantages of this route are claimed to be:

- identical data reporting and analysis formats, irrespective of turbine type; this is important for wind farm owners or operators who have projects using different wind turbines; and
- transparency of calculation of availability and other possible warranty issues.

In addition to the essential equipment needed for a functioning wind farm, it is also advisable, if the project size can warrant the investment, to erect some permanent meteorological instrumentation on met masts. This equipment allows the performance of the wind farm to be carefully monitored and understood. If the wind farm is not performing according to its budget, it will be important to determine whether this is due to poor mechanical performance or less-than-expected wind resource. In the absence of good quality wind data on the site, it will not be possible to make

this determination. Large wind farms therefore usually contain one or more permanent meteorological masts, which are installed at the same time as the wind farm.

## **Construction Issues**

A wind farm may be a single machine or it may be a large number of machines, possibly many hundreds. The design approach and the construction method will, however, be almost identical whatever the size of project envisaged. The record of the wind industry in the construction of wind farms is generally good. Few wind farms are delivered either late or over budget.

Newcomers to the wind industry tend to think of a wind farm as a power station. There are, however, some important differences between these two types of power generation. A conventional power station is one large machine, which will not generate power until it is complete. It will often need a substantial and complicated civil structure, and construction risk will be an important part of the project assessment. However, the construction of a wind farm is more akin to the purchase of a fleet of trucks than it is to the construction of a power station. The turbines will be purchased at a fixed cost agreed in advance and a delivery schedule will be established exactly as it would be for a fleet of trucks. In a similar way the electrical infrastructure can be specified well in advance, again probably at a fixed price. There may be some variable costs associated with the civil works, but this cost variation will be very small compared to the cost of the project as a whole. The construction time is also very short compared to a conventional power plant. A 10 MW wind farm can easily be built within a couple of months.

To minimise cost and environmental effects, it is common to source material for roads from on-site quarries or 'borrow pits', where suitable. It may be

necessary to seek permission for this from the permitting authorities.

## Costs

Wind farm costs are largely determined by two factors: the complexity of the site and the likely extreme loads. The site may be considered complex if the ground conditions are difficult – hard rock or very wet or boggy ground, for example – or if access is a problem. A very windy site with high extreme loads will result in a more expensive civil infrastructure as well as a higher specification for the turbines.

The cost of the grid connection may also be important. Grid connection costs are affected by:

- distance to a suitable network connection point;
- the voltage level of the existing network; and
- the network operator's principles for charging for connections and for the use of the electricity system.

Costs are covered in Part III.

## Commissioning, Operation and Maintenance

Once construction is completed, commissioning will begin. The definition of 'commissioning' is not standardised, but generally covers all activities after all components of the wind turbine are installed. Commissioning of an individual turbine can take little more than two days with experienced staff.

Commissioning tests will usually involve standard electrical tests for the electrical infrastructure as well as the turbine, and inspection of routine civil engineering quality records. Careful testing at this stage is vital if a good quality wind farm is to be delivered and maintained.

The long-term availability of a commercial wind turbine is usually in excess of 97 per cent. This value means that for 97 per cent of the time, the turbine will

be available to work if there is adequate wind. This value is superior to values quoted for conventional power stations. It will usually take a period of some six months for the wind farm to reach full, mature, commercial operation and hence, during that period, the availability will increase from a level of about 80–90 per cent after commissioning to the long-term level of 97 per cent or more.

It is normal practice for the supplier of the wind farm to provide a warranty for between two and five years. This warranty will often cover lost revenue, including downtime to correct faults, and a test of the power curve of the turbine. If the power curve is found to be defective, then reimbursement will be made through the payment of liquidated damages. For modern wind farms, there is rarely any problem in meeting the warranted power curves, but availability, particularly for new models, can be lower than expected in the early years of operation. During the first year of operation of a turbine some 'teething' problems are usually experienced. For a new model this effect is more marked. As model use increases, these problems are resolved and availability rises.

After commissioning, the wind farm will be handed over to the operations and maintenance crew. A typical crew will consist of two people for every 20 to 30 wind turbines in a wind farm. For smaller wind farms there may not be a dedicated O&M crew but arrangements will be made for regular visits from a regional team. Typical routine maintenance time for a modern wind turbine is 40 hours per year. Non-routine maintenance may be of a similar order.

There is now much commercial experience with modern wind turbines and high levels of availability are regularly achieved. Third party operations companies are well established in all of the major markets, and it is likely that this element of the industry will develop very much along the lines associated with other rotating plant and mechanical/electrical equipment.

The building permits obtained in order to allow the construction of the wind farm may have some ongoing

environmental reporting requirements, for example the monitoring of noise, avian activity, or other flora or fauna issues. Similarly there may, depending on the local regulations, be regulatory duties to perform in connection with the local electricity network operator.

Therefore, in addition to the obvious operations and maintenance activity, there is often a management role to perform in parallel. Many wind farms are funded through project finance and hence regular reporting activities to the lenders will also be required.





# I.5 OFFSHORE

## Introduction

Previous chapters have covered the fundamental technical aspects of wind energy, largely from the point of view of onshore installations. This chapter covers those technical issues that are different for offshore wind. The potential for offshore wind is enormous in Europe and elsewhere, but the technical challenges are also great. The capital costs are higher than onshore, the risks are greater, the project sizes are greater and the costs of mistakes are greater.

Offshore wind technology and practice has come a long way in a short time, but there is clearly much development still to be done. Although the fundamentals of the technology are the same onshore and offshore, it is clear that offshore wind technology is likely to diverge further from onshore technology. Methods of installation and operation are already very different from onshore wind generation, with great attention being given to reliability and access.

## Wind Resource Assessment Offshore

This section describes the differences in wind flow, monitoring and data analysis offshore in comparison to onshore. It also highlights the key differences associated with the assessment of the offshore wind resource and the energy production of offshore wind farms when compared with onshore wind farms. Many of the elements of the analyses are common to onshore and offshore projects and it is therefore recommended that this section is read in parallel with the chapters on onshore wind.

## FUNDAMENTALS

Onshore, topographic effects are one of the main driving forces of the wind regime. With no topographic effects offshore, other factors dominate the variation in wind speed with height.

The surface roughness (a parameter used to describe the roughness of the surface of the ground, referred to as  $Z_o$ ) is low, which results in a steeper boundary layer profile (also referred to as the wind shear profile), characterised by the symbol  $\alpha$ . A range of typical values for  $Z_o$  and  $\alpha$  are illustrated in Table I.5.1. Offshore, the surface roughness length is dependent on sea state, increasing with the local wave conditions, which are in turn influenced by wind conditions. However, this relationship is complex, as the sea surface, even when rough, does not present fixed roughness elements such as trees, hills and buildings, as tends to be the case onshore.

The low surface roughness also results in low turbulence intensity. This serves to reduce mechanical loads. It also may increase the energy capture compared to an identical wind turbine at an onshore location with identical mean wind speed.

The coastal zone, where the properties of the boundary layer are changeable, extends away from the shore for varying distances, and this can result in variations in wind speed, boundary layer profiles and turbulence across the wind farm.

Stable flow conditions are also evident offshore. In these situations, air flows with different origins and air

Table I.5.1: Typical values for  $Z_o$  and  $\alpha$

Type of terrain	$Z_o$ (m)	$\alpha$
Mud flats, ice	0.00001	
Smooth sea	0.0001	
Sand	0.0003	0.10
Snow surface	0.001	
Bare soil	0.005	0.13
Low grass, steppe	0.01	
Fallow field	0.03	
Open farmland	0.05	0.19
Shelter belts	0.3	
Forest and woodland	0.5	
Suburb	0.8	
City	1	0.32

temperatures can be slow to mix. This can manifest itself as unusual boundary layer profiles, and in some rare situations wind speed may even reduce with height.

A further factor influencing offshore winds can be the tide level in areas with a high tidal range. The rise and fall of the sea level effectively shifts the location of the turbine in the boundary layer. This can have impacts in variation of mean wind speed within a period of approximately 12 hours, and also on the variation in mean winds across the turbine rotor itself.

Temperature-driven flows due to the thermal inertia of the sea initiate localised winds around the coastal area. Compared to the land, the sea temperature is more constant over the day. During the day, as the land heats up, the warmer air rises and is replaced by cooler air from over the sea. This creates an onshore wind. The reverse effect can happen during the night, resulting in an offshore wind. The strength and direction of the resulting wind is influenced by the existing high-level gradient wind, and in some situations the gradient wind can be cancelled out by the sea breeze, leaving an area with no wind. Finally, as all sailors are aware, close to the coast there are 'backing' and 'veering' effects.

## **MEASUREMENT OFFSHORE**

Offshore wind farms typically use the largest available wind turbines on the market. Their size presents several issues, including understanding the characteristics of the boundary layer up to and above heights of 100 m. Measurements offshore are costly, with costs driven to a large extent by the cost of constructing the support structure for the meteorological mast. These masts cost some €1–5 million, depending on site location and specification, which is perhaps 100 times that required for equivalent onshore work. Offshore monitoring towers are un-guyed, and therefore need to be wider, which can mean measurements are more

susceptible to wind flow effects from the tower. Anemometry equipment is otherwise standard.

If high-quality wind measurements are not available from the site or nearby, there are other sources of information that can be utilised to determine the approximate long-term wind regime at the wind farm location. There are offshore databases for wind data, including meteorological buoys, light vessels and observation platforms. Additionally, meso-scale modelling (based on global reanalysis data sets) and Earth-observation data play a role in preliminary analysis and analysis of spatial variability. None of these are suitable for a robust financing report, however.

## **WIND ANALYSIS OFFSHORE**

Depending on the amount of data available, different analysis methods can be employed. A feasibility study can be carried out based on available wind data in the area. WASP can be used from coastal meteorological stations to give a prediction offshore, which is aided by its latest tool, the coastal discontinuity model (CDM) (see 'Offshore wind resource assessment in European Seas, state-of-the-art' in Sempreviva et al., 2003).

Existing offshore measurements can also be used. There are problems associated with using long-distance modelling, however, especially around the coast, due to the differences in predominant driving forces between onshore and offshore breezes and the variation in the coastal zone in between.

For a more detailed analysis, measurements offshore at the site are necessary. 'Measure correlate predict' (MCP) methods from a mast offshore to an onshore reference station can be used. With several measurement heights and attention to measurement, more accurate modelling of the boundary layer will help extrapolate to heights above the monitoring mast. A photograph of an offshore mast is presented in Figure I.5.1.



Figure I.5.1: An offshore meteorological mast



## ENERGY PREDICTION

The energy prediction step is essentially the same as for onshore predictions. There is generally only minor predicted variation in wind speed over a site. Given the absence of topography offshore, measurements from a mast can be considered representative of a much larger area than would be possible onshore.

For large offshore sites, wake losses are likely to be higher than for many onshore wind farms. The wake losses are increased due to the size of the project and also due to lower ambient turbulence levels – the wind offshore is much smoother. There

is therefore less mixing of the air behind the turbine, which results in a slower re-energising of the slow-moving air, and the wake lasts longer. Observations from the largest current offshore wind farms have identified shortcomings in the classic wind farm wake modelling techniques, due to the large size of the projects and perhaps due to specific aspects of the wind regime offshore. Relatively simple amendments to standard wake models are currently being used to model offshore wake effects for large projects, but further research work is ongoing to better understand the mechanisms involved and to develop second generation offshore wake models.

There is likely to be more downtime of machines offshore, primarily due to difficult access to the turbines. If a turbine has shut down and needs maintenance work, access to it may be delayed until there is a suitable window in the weather conditions. This aspect of offshore wind energy is a critical factor in the economic appraisal of a project. Increasingly sophisticated Monte Carlo-based simulation models are being used to assess the availability of offshore wind farms, which include as variables the resourcing of servicing crews, travel time from shore, the turbine technology itself and sea state.

## Wind Turbine Technology for Offshore Locations

### AVAILABILITY, RELIABILITY AND ACCESS

High availability is crucial for the economics of any wind farm. This depends primarily on high system reliability and adequate maintenance capability, with both being achieved within economic constraints on capital and operational costs. Key issues to be addressed for good economics of an offshore wind farm are:

- minimisation of maintenance requirements; and
- maximisation of access feasibility.

The dilemma for the designer is how best to trade the cost of minimising maintenance by increasing reliability – often at added cost in redundant systems or greater design margins – against the cost of systems for facilitating and increasing maintenance capability. Previous studies within the EU research programmes, such as OptiOWECS, have considered a range of strategies from zero maintenance (abandonment of faulty offshore turbines) to highly facilitated maintenance.

Access is critical as, in spite of the direct cost of component or system replacement in the difficult offshore conditions, lost production is often the greatest cost penalty of a wind turbine fault. For that reason much attention is given to access. Related to the means of access is the feasibility of various types of maintenance activities and whether or not support systems (cranes and so on) and other provisions are needed in the wind turbine nacelle systems.

### **Impact on Nacelle Design**

The impacts of maintenance strategy on nacelle design relate to:

- Provision for access to the nacelle;
- Systems in the nacelle for handling components; and
- The strategic choice between whether the nacelle systems should be (a) designed for long life and reliability in an integrated design that is not particularly sympathetic to local maintenance and partial removal of subsystems or (b) designed in a less cost-effective modular way for easy access to components.

### **Location of Equipment**

Transformers may be located in the nacelle or inside the tower base. Transformer failures have occurred in offshore turbines, but it is not clear that there is any fundamental problem with location in either the nacelle or the tower base.

### **Importance of Tower Top Mass**

The tower top mass is an important influence on foundation design. In order to achieve an acceptable natural frequency, greater tower top mass may require higher foundation stiffness, which could significantly affect the foundation cost for larger machines.

### **Internal Cranes**

One option is to have a heavy duty internal crane. Siemens and Vestas have adopted an alternative concept, which in general consists of a lighter internal winch that can raise a heavy duty crane brought in by a maintenance vessel. The heavy duty crane may then be hoisted by the winch and set on crane rails provided in the nacelle. Thus it may be used to lower major components to a low-level platform for removal by the maintenance vessel.

Critical and difficult decisions remain about which components should be maintained offshore in the nacelle, which can be accessed, handled and removed to shore for refurbishment or replacement, and when to draw a line on component maintenance capability and accept that certain levels of fault will require replacement of a whole nacelle.

### **Means of Access**

The costs of turbine downtime are such that an effective access system offshore can be relatively expensive and still be justified. Helicopter access to the nacelle top has been provided in some cases. The helicopter cannot land, but can lower personnel. Although having a helipad that would allow a helicopter to land is a significantly different issue, the ability to land personnel only on the nacelle top of a wind turbine has very little impact on nacelle design. Although adopted for the Horns Rev offshore wind farm, helicopter access is probably too expensive as a routine method of transporting personnel to and from offshore wind

turbines, assuming current project sizes and distance from shore.

### **Access Frequency**

At Horns Rev, which is the first major offshore wind farm in the North Sea, a vast number of worker transfers have taken place since construction, and this is a concern for the health and safety of personnel. It is expected (and essential) that the required number of transfers for the establishment and commissioning of offshore wind plant will reduce as experience is gained.

### **Access Impediments**

In the Baltic Sea especially, extensive icing occasionally takes place in some winters. This changes the issues regarding access, which may be over the ice if it is frozen solid or may use ice-breaking ships. Also, the ice in general is in motion and may be quite unstable. Lighthouses have been uprooted from their foundations and moved by pack ice. The wind turbine foundation design used by Bonus in the Middelgrunden offshore wind farm, situated in shallow water between Denmark and Sweden, provides for a section at water level with a bulbous shape. This assists in ice breaking and easing the flow of ice around the wind turbine, thereby reducing loads that would tend to move the whole foundation.

In the European sites of the North Sea, the support structure design conditions are more likely to relate to waves than ice, and early experience of offshore wind has shown clearly that access to a wind turbine base by boat is challenging in waves of around 1 m height or more.

Currently most standard boat transfers cannot – and should not – be performed in sea states where the significant wave height is greater than 1.5 m and wind conditions are in excess of 12 m/s. This sea state constraint is generally not an onerous parameter for wind farms located in the Baltic region. However, in

more exposed locations, such as in UK and Irish waters, the average number of days where the wave height is greater than 1.5 m is considerably greater.

### **Feasibility of Access**

Operating in concert with the wave height restrictions are restrictions from the water depth, swell and under-water currents. As an example, UK wind farms are generally sited on shallow sandbanks, which offer advantages in easier installation methods, scaled reductions in foundation mass requirements and the tendency of shallow sandbanks to be located in areas away from shipping channels. However, shallow waters, particularly at sandbank locations where the seabed topography can be severe, amplify the local wave height and can significantly change the wave form characteristics. Generally speaking, the turbine in a wind farm that is located in the shallowest water will present the most access problems.

Wave data that is representative of UK offshore wind farm sites shows that access using a standard boat and ladder principle (significant wave heights up to 1.5m) is generally possible for approximately 80 per cent of the available time. However, this accessibility rate is too low for good overall wind farm availability. In winter, accessibility is typically worst when there is the greatest likelihood of turbine failures; yet at these times there are higher winds and hence potentially higher levels of production loss. Accessibility can be improved to above 90 per cent if access is made possible in significant wave heights between 2.0 and 2.5 m. Providing access in yet more extreme conditions is probably too challenging, considering cost, technical difficulty and safety. A safety limit on sea conditions has to be set and rigidly adhered to by the wind farm operator. This implies that 100 per cent accessibility to offshore wind plant will not be achievable and 90 per cent accessibility seems a reasonable target. Improvements in availability thereafter must be achieved through improved system reliability.

Safe personnel access is currently one of the most important topics under discussion in offshore wind energy. For example, the British Wind Energy Association, in consultation with the UK Health and Safety Executive, has produced guidelines for the wind energy industry (BWEA, 2005). These guidelines were issued as general directions for organisations operating or considering operating wind farms.

### **Access Technology Development**

There may be much benefit to be gained from the general knowledge of offshore industries that are already developed, especially the oil and gas industry. However, there are major differences between an offshore wind farm and, for example, a large oil rig. The principal issues are:

- There are multiple smaller installations in a wind farm and no permanent (shift-based) manning, nor the infrastructure that would necessarily justify helicopter use.
- Cost of energy rules wind technology, whereas maintenance of production is much more important than access costs for oil and gas.

Thus, although the basis of solutions exists in established technology, it is not the case that the existing offshore industry already possesses off-the-shelf solutions for wind farm construction and maintenance. This is evident in the attention being given to improved systems for access, including the development of special craft.

### **Conclusions Regarding Access Issues**

There appears to be a clear consensus on offshore wind turbine access emerging for UK sites. Purpose-built aluminium catamaran workboats are currently in use for the several wind farms. Catamarans generally provide safe access in sea conditions with a maximum

significant wave height up to 1.5 m. On occasion this figure has been exceeded by skippers experienced in offshore wind transfers on a particular site.

In UK waters it is generally accepted that the standard boat and ladder access principle is practicable for approximately 50–80 per cent of the available service time, depending on the site. However, when this accessibility figure is considered in concert with the overall wind farm availability equation, there is scope for improvement. The main reason for improvement is that winter accessibility rates are typically much worse than for the summer period. This is compounded with a higher likelihood of turbine failures in winter and also higher winds, hence higher levels of production loss.

With some effort this accessibility figure can be improved markedly – that is to say, where access can be made possible in significant wave heights of between 1.5 and 2.0 m. Providing access above 2.0 m becomes an economically and technically challenging decision. It is likely that significant expenditure and technical resources would be necessary to gain modest incremental improvements in access rates above the 2.5 m significant wave threshold. Furthermore, it may be proved, using analytical techniques, that around 80 per cent of the development and capital costs would only net, at most, gains of 20 per cent in accessibility.

In short, it is doubtful from a pragmatic and safety perspective whether personnel should be expected to attempt any transport and transfer in wave conditions in excess of 2–2.5 m. A safety limit on sea conditions has to be set and rigidly adhered to by a wind farm operator, with acceptance that a 100 per cent accessibility rate will never be achievable in an offshore wind context. Project economics based on the premise of accessibility rates around 90 per cent of the available time is a reasonable target. Improvements in availability thereafter must be achieved through improved reliability of machinery.

In summary, there is an appreciable benefit in increasing accessibility rates upwards from the current 1.2 to 1.5 m threshold to 2.0 m. This has proven to be achievable using catamarans. There are a number of alternative vessels at the concept stage that are being designed to allow safe transfer in 2 m significant waves. It may be possible to achieve further improvements in accessibility using specialised workboats fitted with flexible gangways that can absorb the wave energy that cannot be handled by the vessel. Alternatively, larger vessels with a greater draught, which are more inherently stable in rougher sea conditions, must be employed. However, the drawback for offshore wind energy is that foundation technology and the economics for many projects dictate that turbines should be installed in shallow banks, hence shallow draught service vessels are obligatory.

## LIGHTNING RISK OFFSHORE

Lightning has been more problematic offshore than expected. The answer, however, lies with providing wind turbine blades with better methods of lightning protection, as used on the more problematic land-based sites, rather than looking for systems to ease handling and replacement of damaged blades. The consequences of lightning strikes can be severe if systems are not adequately protected.

## MAINTENANCE STRATEGY – RELIABILITY VERSUS MAINTENANCE PROVISION

Regarding cost of energy from offshore wind, a general view is emerging that it is a better to invest in reliability to avoid maintenance than in equipment to facilitate it. Also, expenditure on maintenance ships and mobile gear is generally more effective than expenditure per machine on added local capability such as nacelle cranes. In selected cases, a strategy to facilitate in-situ replacement of life-limited components (such as seals) may be advised.

## Wind Farm Design Offshore

Designing an offshore wind farm is a staged process involving:

- data-gathering;
- preliminary design and feasibility study;
- site investigation;
- concept development and selection;
- value engineering;
- specification; and
- detailed design.

Close interaction throughout the design process is required, including interaction about the grid connection arrangements and constraints introduced through the consenting process. Key aspects of the design, and the process of arriving at that design, are described in the following sections.

The capital cost of offshore projects differs markedly from those onshore, with perhaps 50 per cent of the capital cost being due to non-turbine elements, compared to less than 25 per cent in onshore projects. Figure 1.5.2 shows a typical breakdown of cost for an offshore wind farm.

## SITE SELECTION

The selection of the site is the most important decision in the development of an offshore wind farm. It is best accomplished through a short-listing process that draws together all known information on the site options, with selection decisions driven by feasibility, economics and programme, taking account of information on consenting issues, grid connection and other technical issues discussed below.

## WIND TURBINE SELECTION

Early selection of the wind turbine model for the project is typically necessary so that the design process

Figure I.5.2: Capital cost breakdown for a typical offshore wind farm

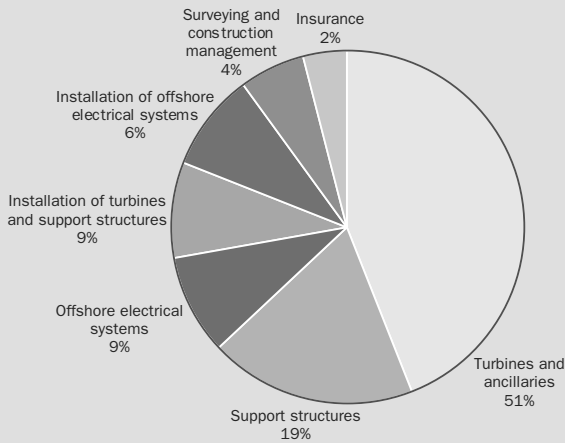

Source: Garrad Hassan

for support structures (including site investigations), electrical system and grid connection can progress. Offshore projects require use of the larger wind turbines on the market, meaning that there is often limited

choice; hence, securing the wind turbine model may be necessary to start up the project programme.

### LAYOUT

The process for designing the layout of an offshore wind farm is similar to the process for an onshore wind farm, albeit with different drivers. Once the site is secured by a developer, the constraints and known data on the site are evaluated and input in the layout design, as shown in Figure I.5.3.

One driver that often dominates onshore wind farm design is the noise footprint of the project, which is not usually an issue for offshore projects.

The layout design process evaluates and compares layout options in relation to technical feasibility, overall capital cost and the predicted energy production.

Determining the optimum layout for an offshore wind farm involves many trade-offs. One example of such a trade-off is related to the array spacing, where a balance must be struck between array losses, that is to say, energy production, and electrical system costs and efficiency. Several other such trade-offs exist.

Figure I.5.3: Layout design process

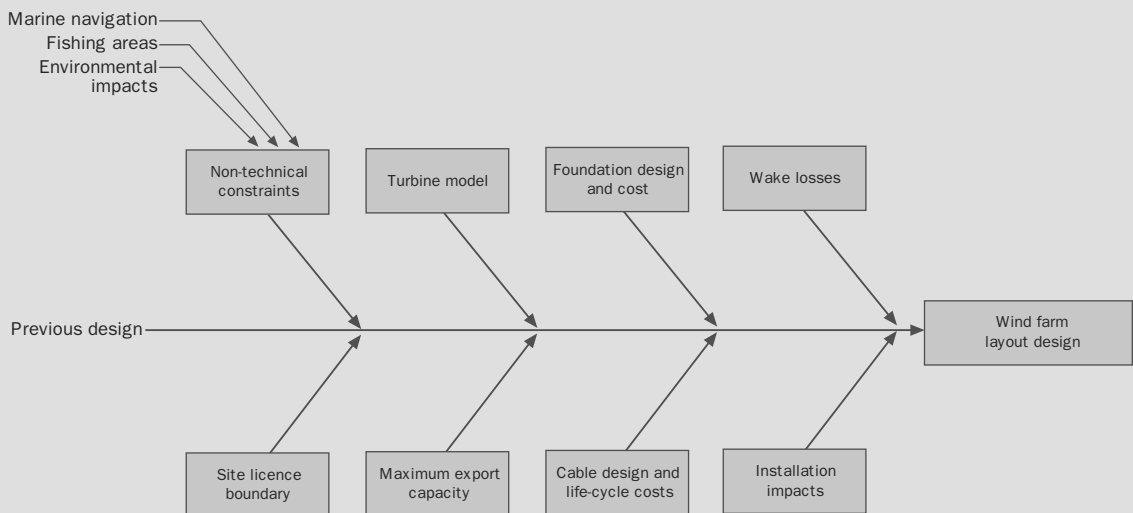

Source: Garrad Hassan

The experience to date is that for sites of homogeneous depth and soil properties, revenue, and hence production, has a dominant impact on the cost of energy, and as a result the design of the layout is dictated by energy production. However, where the water depth and soil properties vary widely across a site, more complex trade-offs must be made between production, electrical system costs and support structure costs, including installation costs.

## OFFSHORE SUPPORT STRUCTURES

Support structures for offshore wind turbines are highly dynamic, having to cope with combined wind and hydrodynamic loading and complex dynamic behaviour from the wind turbine. It is vital to capture the integrated effect of the wind and wave loads and

the wind turbine control system, as this is a situation where the total loading is likely to be significantly less than the sum of the constituent loads. This is because the loads are not coincident and because the aerodynamic damping provided by the rotor significantly damps the motions due to wave loading.

Structures to support wind turbines come in various shapes and sizes; the most common are illustrated in Table I.5.2 and Figures I.5.4 to I.5.7. Monopiles have been chosen for most of the installed offshore wind farms to date. Concrete gravity base structures have also been used on several projects. As wind turbines get larger, and are located in deeper water, tripod or jacket structures may become more attractive.

The design process for offshore wind turbine support structures is illustrated in Figure I.5.8.

Table I.5.2: Support structure options

Structure	Examples	Use	Notes
Monopile	Utgrunden, SE; Blyth, UK; Horns Rev, DK; North Hoyle, UK; Scroby Sands, UK; Arklow, Ireland; Barrow, UK; Kentish Flats, UK	Shallow to medium water depths	<ul style="list-style-type: none"> <li>Made from steel tube, typically 4–6 m in diameter</li> <li>Installed using driving and/or drilling method</li> <li>Transition piece grouted onto top of pile</li> </ul>
Jacket	Beatrice, UK	Medium to deep water depths	<ul style="list-style-type: none"> <li>Made from steel tubes welded together, typically 0.5–1.5 m in diameter</li> <li>Anchored by driven or drilled piles, typically 0.8–2.5 m in diameter</li> </ul>
Tripod	Alpha Ventus, DE	Medium to deep water depths	<ul style="list-style-type: none"> <li>Made from steel tubes welded together, typically 1.0–5.0 m in diameter</li> <li>Transition piece incorporated onto centre column</li> <li>Anchored by driven or drilled piles, typically 0.8–2.5 m in diameter</li> </ul>
Gravity base	Vindeby, DK; Tuno Knob, DK; Middlegrunden, DK; Nysted, DK; Lilgrund, SE; Thornton Bank, BE	Shallow to medium water depths	<ul style="list-style-type: none"> <li>Made from steel or concrete</li> <li>Relies on weight of structure to resist overturning; extra weight can be added in the form of ballast in the base</li> <li>Seabed may need some careful preparation</li> <li>Susceptible to scour and undermining due to size</li> </ul>
Floating structures	None	Very deep water depths	<ul style="list-style-type: none"> <li>Still under development</li> <li>Relies on buoyancy of structure to resist overturning</li> <li>Motion of floating structure could add further dynamic loads to structure</li> <li>Not affected by seabed conditions</li> </ul>

Figure I.5.4: Monopile

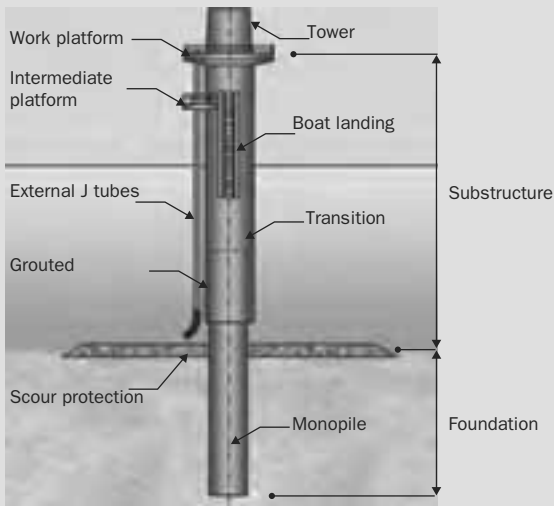

Source: Garrad Hassan

Figure I.5.6: Jacket structure

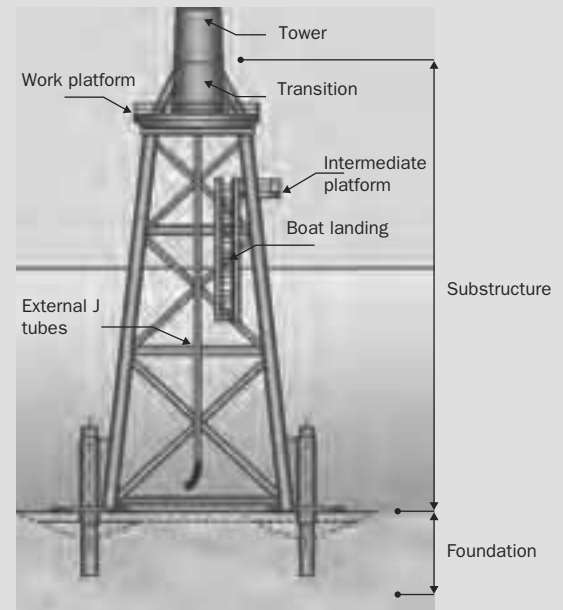

Source: Garrad Hassan

Figure I.5.5: Gravity base structure (indicative only: actual implementations can vary significantly)

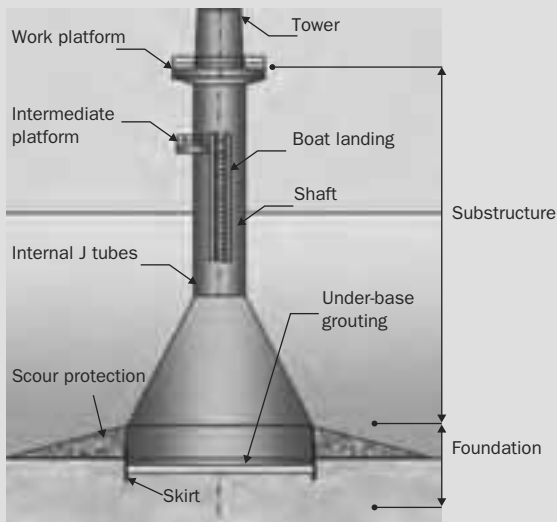

Source: Garrad Hassan

The structure designs are strongly influenced by met-ocean site conditions and site investigations. Metocean conditions are determined by detailed hydrodynamic analysis based on long-term hindcast model data and calibrated against short-term site wave measurements.

Site investigations are major tasks in their own right, requiring careful planning to achieve optimum results within programme and financial constraints. These involve a combination of geophysical and geotechnical measurements. The geotechnical investigations identify the physical properties of the soils into which foundations are to be placed and are achieved using cone penetrometer or borehole testing. Geophysical tests involve measurement of water depth and of the seismic properties of the underlying soil layers and can be used to interpolate the physical findings of geotechnical tests. The type and extent of geotechnical tests is dependent on the soil type occurring at the site and the homogeneity of those site conditions.



Figure I.5.7: Tripod structure (third leg hidden)

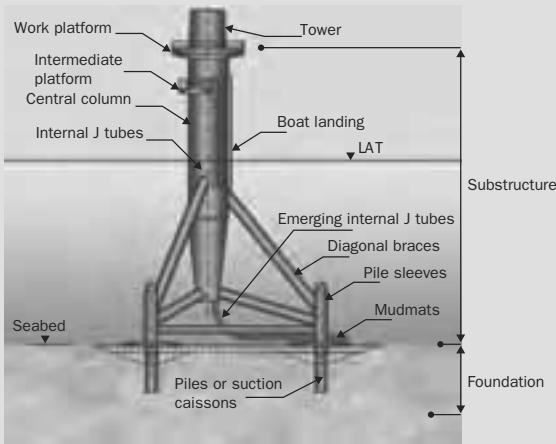

Source: Garrad Hassan

Design of the secondary structures, such as decks, boat landings and cable J-tubes, is typically developed in the detailed design phase. These details have a major impact on ease of construction, support structure maintenance requirements, accessibility of the wind turbines and safety of personnel during the operations phase. Hence a significant design period is recommended.

Where an offshore substation is required, this is likely to require a substantial support structure, although as it does not have the complexities of wind turbine loading, it is a more conventional offshore structure to design. As discussed in the following section, an offshore substation may range from a unit of below 100 MW with a small single deck structure to a large, multi-tier high voltage DC (HVDC) platform.

### ELECTRICAL SYSTEM

An offshore wind farm electrical system consists of six key elements:

1. wind turbine generators;
2. offshore inter-turbine cables (electrical collection system);
3. offshore substation (if present);
4. transmission cables to shore;
5. onshore substation (and onshore cables); and
6. connection to the grid.

Figure I.5.9 illustrates these schematically and the following subsections describe them in more detail.

The design of the electrical system is determined by the characteristics of the wind turbine generators and

Figure I.5.8: Typical primary support structure design inputs

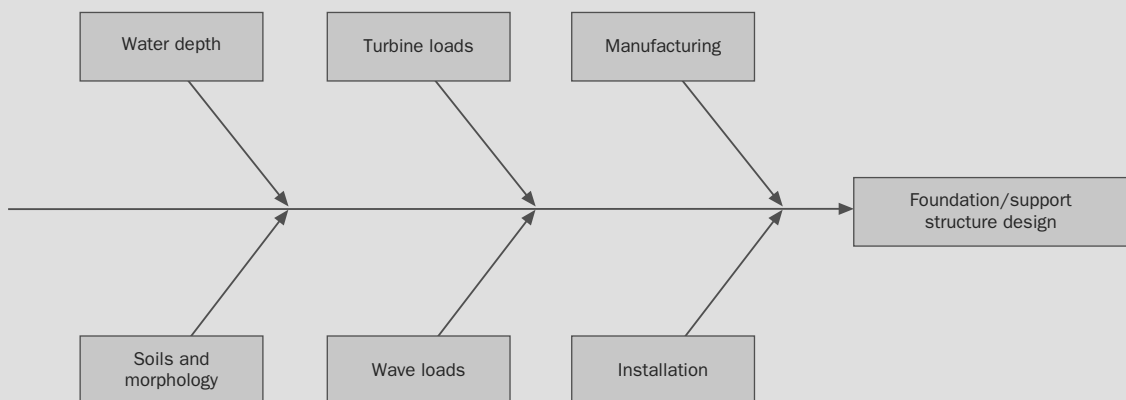

Source: Garrad Hassan

Figure I.5.9: Typical single line diagram

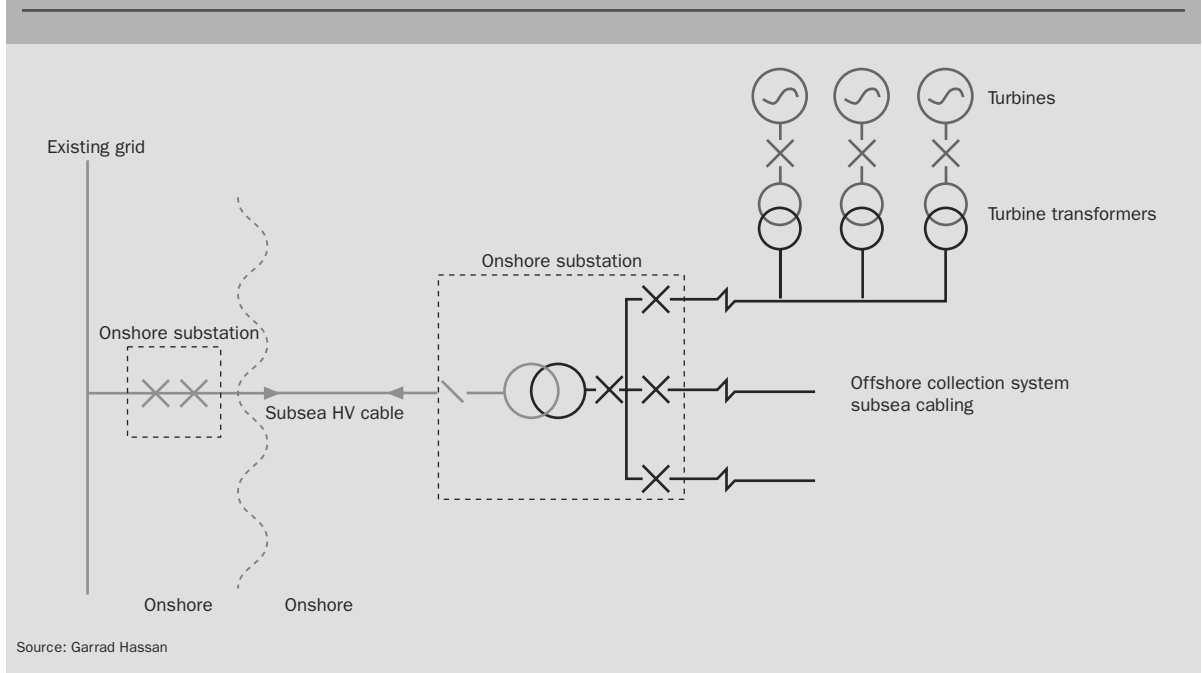

of the network to which the project is to be connected, as well as regulations imposed upon it, notably through grid codes. The network operator controls the grid to meet its operational objectives and also requires a degree of control over large generators (which may include offshore wind farms). Additionally, the wind farm must be designed to respond appropriately to grid faults. These demands can be expected for any large wind farm located offshore (see Part II).

Wind turbine control and electrical systems are constantly evolving to provide improved characteristics and fault response for the purpose of grid integration. Nevertheless, the wind farm electrical system can be expected to have additional functional requirements in addition to the basic transmission from turbines to the grid connection point.

### Offshore Substations

Offshore substations are used to reduce electrical losses by increasing the voltage and then exporting

the power to shore. Generally a substation does not need to be installed if:

- the project is small (~100 MW or less);
- it is close to shore (~15 km or less); or
- the connection to the grid is at collection voltage (for example 33 kV).

Most early offshore wind projects met some or all of these criteria, so were built without an offshore substation. However, most future offshore wind farms will be large and/or located far from shore, and so will require one or more offshore substations.

Offshore substations typically serve to step up the voltage from the site distribution voltage (30–36 kV) to a higher voltage (say 100–220 kV), which will usually be the connection voltage. This step-up dramatically reduces the number of export circuits (subsea cables) between the offshore substation and the shore. Typically, each export circuit may be rated in the range 150–200 MW.

Such substations may be configured with one or more export circuits. Future units will be larger and more complex. To date, no standard substation layout has yet evolved.

For projects located far from the grid connection point, or of several hundred megawatts in capacity, AC transmission becomes costly or impossible, due to cable-generated reactive power using up much of the transmission capacity. In such cases, HVDC transmission is becoming an option. Such a system requires an AC/DC converter station both offshore and onshore; both stations are large installations.

### Onshore Substations

Design of the onshore substation may be driven by the network operator, but there will be some choices to be made by the project developer. Generally, the onshore substation will consist of switchgear, metering, transformers and associated plant. The onshore substation may also have reactive compensation equipment, depending on the network operator requirements and the design of the offshore network.

### Subsea Cables

Subsea cables are of well-established design. Each circuit runs in a single cable containing all three phases and optical fibre for communications, with a series of fillers and protective layers and longitudinal water blocking to prevent extensive flooding in the event of the external layers failing.

Inter-turbine (array) cables are typically rated at 30 to 36 kV and installed in single lengths from one turbine to its neighbour, forming a string (collection circuit) feeding the substation. Each collection circuit is usually rated up to 30 MW. Export cables are of similar design but for higher voltage, typically 100 to 220 kV. Cables are terminated at each structure through a

vertical tube from seabed to above water level (J-tube or I-tube) and into conventional switchgear.

Long-term reliability of the subsea cables is a major concern, addressed mainly by ensuring the safe burial of the cables at a depth that avoids damage from trawlers and anchors and the exposure of cables to hydrodynamic loading.

## INSTALLATION

The installation of the wind turbines and their support structures is a major factor in the design of offshore wind farms, with the specific challenge of having to perform multiple repeated operations in difficult offshore locations. As well as being a significant contributor to the capital cost, the installation process may drive the selection of support structure technology.

The substation installation is also a major operation, albeit a single one, unlike the wind turbine and wind turbine foundation installation, and therefore much more conventional in the offshore industry. A large crane vessel is likely to be required – either a shear-leg crane or other heavy lift unit. Alternatively, self-installing substation designs may find an increasing role in the future.

Cable installation is a significant industry sector, with specialist design and planning, and installation vessels and equipment. The design and planning of the cable installation is an early activity, covering:

- identification of hazards to cables;
- site investigation to identify seabed properties (geophysical survey, vibrocore sampling, cone penetrometer tests, boreholes);
- development of burial protection indices;
- scour protection;
- cable route selection;
- cable transport; and
- vessel and equipment selection.

## Future Trends for Offshore Wind

### GENERAL

The offshore wind sector remains relatively immature, and despite the first demonstration project being built in 1991, the total installed capacity only breached the 1000 MW barrier in 2007/2008. Added to this, experience has shown that the sector presents unique technical challenges that must be addressed through research and development efforts:

- any project involves multiple distributed installations, spread over much larger areas and in much larger numbers than other offshore industries;
- nearshore shallow water (for most projects) siting – unlike oil and gas rigs, sea defence works, and ports and harbours; and
- more stringent economics than oil and gas.

These factors combine so that there is limited borrowing available from other sectors, and technology has had to evolve within a short timescale on a small number of projects, leaving significant scope for further maturing. This issue covers all parts of the industry, including:

- wind turbines;
- wind turbine support structures;
- modelling tools;
- electrical infrastructure;
- assembly and installation; and
- operations and maintenance.

Two drivers cut across all these areas: safety of personnel and the public, and environmental protection.

EWEA has led the EU Wind Energy Technology Platform (see Chapter I.7) and has convened a working group to identify necessary future technical initiatives for offshore wind. The outcomes are discussed in Chapter I.7.

## WIND TURBINES

Wind turbine technology in general is discussed in Chapter I.3, with some future innovative wind energy conversion systems that may be exploited on land or offshore reviewed under 'Future innovations'.

It has long been acknowledged that some of the design drivers for a wind turbine installed offshore are fundamentally different from those installed onshore, specifically:

- the non-turbine elements of an offshore project represent a much higher proportion of the capital cost, with that cost element only partially scaling with turbine size;
- acceptable noise levels are much higher offshore; and
- better reliability is required offshore.

These drivers have already influenced the design of wind turbines used offshore, and this is leading to the development of wind turbines specifically designed for offshore use with features such as:

- larger rotors and rated power;
- higher rotor tip speeds;
- sophisticated control strategies; and
- electrical equipment designed to improve grid connection capability.

Wind resource assessment offshore provides more background, but other technological innovations that may be deployed in future offshore turbines include:

- two-bladed rotors;
- downwind rotors;
- more closely integrated drive trains;
- multi-pole permanent magnet generators;
- high temperature superconductors (in generators); and
- high voltage output converters (eliminating the need for turbine transformers).

## WIND TURBINE SUPPORT STRUCTURES

As shown in Figure I.5.2, support structures form a significant proportion of offshore wind development costs. It is expected that there will be both innovation and value engineering of structure designs and improved manufacturing processes to improve the economics and meet the demands for more challenging future sites and wind turbines.

Such developments are likely to include modifications to conventional designs, scale-up of manufacturing capacity and processes, and more novel design concepts. Such innovative designs may include:

- suction caisson monotowers;
- use of suction caissons as the foundation of jacket or tripod structures;
- application of screw piles;
- floating structures; and
- braced supports to monopiles.

There are two key aspects to the maturing of offshore support structures:

- acquisition of data on the behaviour of the existing structures in order to support research into the development of improved design tools and techniques and better design standards; this will be used to extend the life of structures, to reduce costs and to develop risk-based life-cycle approaches for future designs; and
- the build-up of scale and speed in production in order to achieve cost reduction and the capacity necessary to supply a growing market

The development of floating structures, while long-term, will be a major advance if successful. This is discussed in 'Offshore support structures' above.

## MODELLING TOOLS

The offshore wind sector will deploy turbines of greater size and in greater numbers than has been

done previously. Understanding of the engineering impacts of this is achieved through modelling, and this increase in scale requires development and validation of the industry's modelling tools. Associated with this is the refinement of design standards. The priority areas that must be addressed for large offshore wind farms are:

- development of wind turbine wakes within the wind farm;
- meso-scale modifications to the ambient flow in the immediate environs of the wind farm;
- downstream persistence of the modification to ambient flow, and therefore the impact of neighbouring wind farms upon each other; and
- dynamic loads on wind turbines deep within wind farms.

## ELECTRICAL INFRASTRUCTURE

Incremental development in electrical equipment (switchgear, transformers and reactive power compensation equipment) is to be expected, driven by the wider electricity supply industry. The offshore wind business will soon be the largest market for subsea cables and so some innovations there may be driven by the specific requirements of the sector, although cables are a relatively mature technology. Voltage-source high voltage DC transmission is a relatively new commercial technology, and one that will find extensive application in offshore wind.

The major electrical impact of the offshore sector will be the reshaping of the transmission network of the countries involved in order to serve these major new generating plants. Also to be expected is an increase in the interconnection of countries to improve the firmness of national power systems, which may also involve providing an international offshore transmission network dedicated to serving offshore wind projects.

### ASSEMBLY AND INSTALLATION

Future technical developments in the construction process are likely to be:

- improvements in harbour facilities that are strategically located for the main development regions;
- construction of further purpose-built installation equipment for the installation of wind turbines, support structures and subsea cables: vessels and also piling hammers, drilling spreads and cable ploughs; and
- development of safe, efficient, reliable and repeatable processes to reduce costs, minimise risks, guarantee standards and deliver investor confidence.

### OPERATIONS AND MAINTENANCE

Successful performance of O&M is most critically dependent on service teams being able to access the wind farm as and when needed. Good progress has been made on this in recent years and accessibility has improved significantly. This has been achieved by incremental improvements in:

- vessels used;
- landing stages on the wind turbine structures; and
- procedures.

Future offshore wind farms offer new access challenges, being larger and much further offshore. This will result in increased use of helicopters for transferring service crews, larger vessels to give fast comfortable transit from port to site and the use of offshore accommodation platforms, combined with evolution of strategies to perform O&M.

### FLOATING SYSTEMS

The US Department of Energy (DoE) has hosted conferences on 'deepwater' solutions in recent years. In both the EU and the US for over ten years, there has

been exploratory research of floating offshore systems and preliminary development of design tools for modelling a wind turbine system on a dynamically active support that is affected by wave climate. Until recently, such technology, even at the level of a first demonstration, was considered rather far in the future. However, interest has accelerated and demonstration projects have been announced.

The main drivers for floating technology are:

- access to useful resource areas that are in deep water yet often near the shore;
- potential for standard equipment that is relatively independent of water depth and seabed conditions;
- easier installation and decommissioning; and
- the possibility of system retrieval as a maintenance option.

The main obstacle to the realisation of such technology is:

- development of effective design concepts and demonstration of cost-effective technology, especially in respect of the floater and its mooring system.

#### StatoilHydro-Siemens

StatoilHydro and Siemens Power Generation entered into an agreement to cooperate on technology to develop floating wind turbines, based on StatoilHydro's Hywind concept. StatoilHydro is aiming to build the world's first full-scale floating wind turbine and test it over a two-year period offshore near Karmøy, an island to the southwest of Norway. The company has announced an investment of approximately NOK400 million for a planned start-up in autumn 2009.

A Siemens 2.3 MW wind turbine (80 m rotor diameter) is set on a floating column of the spar-buoy type, a solution long established in oil and gas production platforms and other offshore floating systems.

The flotation element is proposed to have a draught of 100 m below the sea surface, and to be moored to the seabed using three anchor points. The system

can be employed in waters depths ranging from 120 to 700 m.

The combination of two established technology solutions in the wind turbine and spar buoy may be considered a prudent approach to the development of offshore floating systems.

StatoilHydro has also acquired a substantial share in the technology company Sway, which is developing a highly innovative solution for system support. The SWAY® system (Figure I.5.10) is a floating foundation capable of supporting a 5 MW wind turbine in water

depths ranging from 80 m to more than 300 m in challenging offshore locations.

In the SWAY® system, the tower is stabilised by elongation of the floating tower to approximately 100 m under the water surface and by around 2000 tonnes of ballast in the bottom. A wire bar gives sufficient strength to avoid tower fatigue. Anchoring is secured with a single tension leg between the tower and the anchor.

The tower takes up an equilibrium tilt angle (typically around 5 to 10°) due to the wind thrust on the

Figure I.5.10: The SWAY® concept



rotor. During power production in storm conditions, there is expected to be a further variation of only  $\pm 0.5$  to  $1.0^\circ$  from the equilibrium tilt angle due to wave action.

The concept exploits active control of rotor thrust, and claims to achieve substantial cost savings over competing technology for deep water applications. The first full-scale wind turbine is expected to be built and installed in 2010–2012.

### **Blue H**

A prototype installation using a concept similar to the tension-leg platform developed in the oil and gas industry was launched in late 2007 by Blue H Technologies of The Netherlands. The installation carries a two-bladed wind turbine, and is due for full installation and testing in 2008 in a water depth of over 100 m, approximately 17 km offshore from Puglia, Italy.







## I.6 SMALL WIND TURBINES

### Introduction

Small wind turbines (SWTs) are used in two main areas:

1. 'autonomous' electrical systems (also called 'stand-alone', 'grid-isolated' or 'off-grid'), in other words those that are not connected to any larger electrical system and are therefore solely responsible for the control of voltage and frequency; and
2. 'distributed generation', in other words systems with small generators connected to a larger public distribution network, where there is a network operator responsible for overall control (this is also often called 'grid-connected' or 'on-grid' generation).

Despite the attention given to multi-megawatt wind farms, the markets for autonomous electrical systems and distributed generation using small wind turbines can be attractive if prices of conventional electricity and fossil fuels are sufficiently high, or in many developing countries, where hundreds of millions of people live without access to electricity.

However, despite the maturity reached in the development of the large and medium-sized wind technology for wind farms, the state-of-the-art for small wind turbines is far from technological maturity and economic competitiveness. Average costs for current stand-alone wind turbines vary from €2500 to €6000 per installed kW, while in distributed generation, a small wind turbine can vary from €2700 to €8000 per installed kW, the additional cost mainly due to the power converter required for grid connection. Both these figures contrast with the costs of large wind turbines, which are in the region of €1500/kW.

Concerning the performance analysis for small wind turbines, the average power density is around 0.15 to 0.25 kW/m<sup>2</sup>, because of the limited wind potential in sites where the energy is required, compared to typical sites for large wind turbines in wind farms.

The technology of SWTs is clearly different from that used in large wind turbines. These differences affect all of the subsystems: mainly the control and electrical systems, but also the design of the rotor. Most of the SWTs existing on the market are machines that have developed in an almost 'hand-crafted' way, with less mature technology compared to that achieved by large wind turbines.

SWTs have great potential, but some challenges have to be addressed to produce reliable machines. IEC standards do exist for SWTs (IEC 61400-2 for design requirements for SWT) and there are applicable standards from large wind, such as power performance or noise emissions measurements; however, something more has to be done in order to develop more appropriate standards and simpler ways to display the results obtained to end users.

In spite of these barriers, the market in developed countries is promising for grid-connected and off-grid applications, due to promotion policies (such as capital cost buy-down, feed-in tariffs and net metering), and even more so for developing countries, because of the continuing decrease in specific costs and the increasing need for energy.

Table I.6.1 gives a useful categorisation of commercial SWT ranges by rated power, from a few watts to 100 kW.

The values that define the ranges for this classification have been chosen from the norms and legislation affecting SWTs. The value of 40 m<sup>2</sup> was the limit established in the first edition of the IEC 61400-2 Standard and is the range intended at the present time for integration of SWTs into the built environment; the 200 m<sup>2</sup> limit was established in the second edition of the above-mentioned IEC 61400-2 Standard in 2006, and includes most SWT applications. Finally, the limit of 100 kW is defined in many countries as the maximum power that can be connected directly to the low voltage grid. The pico-wind range is commonly accepted as those SWTs smaller than 1 kW.

Table I.6.1: Classification of SWTs

Rated power (kW)	Rotor swept area (m <sup>2</sup> )	Sub-category
$P_{rated} < 1 \text{ kW}$	$A < 4.9 \text{ m}^2$	Pico-wind
$1 \text{ kW} < P_{rated} < 7 \text{ kW}$	$A < 40 \text{ m}^2$	Micro-wind
$7 \text{ kW} < P_{rated} < 50 \text{ kW}$	$A < 200 \text{ m}^2$	Mini-wind
$50 \text{ kW} < P_{rated} < 100 \text{ kW}$	$A < 300 \text{ m}^2$	(No clear definition adopted yet)

Source: CIEMAT

the ranges defined in the introduction to this chapter (Table I.6.1). The table shows how isolated systems with SWTs offer solutions for almost any application whenever there is enough wind resource at the site. Depending on the size of the system, the three technological solutions for isolated systems are:

1. wind home systems;
2. hybrid systems; and
3. wind-diesel systems.

### Markets and Applications for SWTs

The different applications for which SWTs are especially suitable have been summarised in Table I.6.2 for the main two markets identified: off-grid applications and grid-connected applications.

Table I.6.2 tries to reflect the possible combinations, according to market, application and size of SWT, in

The status of these options will be commented on under ‘Isolated applications’.

In the case of on-grid applications, the possibilities are also numerous, depending on the available space for the installation and on legal and economic constraints. Some options have also been identified, including integration into the built environment, and single and multiple wind turbine installations. The status of these other options is discussed under ‘Grid-connected applications’.

Table I.6.2: Applications of small wind turbines

Rated power/system	Wind-diesel								Wind mini-farm								
	Wind hybrid				Single wind turbine				Build integrated								
	Wind home system																
$P < 1 \text{ kW}$	X	X	X	X	X	X	X			X	X	X	X				
$1 \text{ kW} < P < 7 \text{ kW}$	X	X	X	X	X	X	X	X			X	X	X	X	X	X	X
$7 \text{ kW} < P < 50 \text{ kW}$					X	X	X	X	X				X	X	X	X	X
$50 \text{ kW} < P < 100 \text{ kW}$								X	X						X	X	X
Small wind systems applications	Sailboats	Signalling	Street lamp	Remote houses/dwellings	Farms	Water pumping	Seawater desalination	Village power	Mini-grid	Street lamp	Buildings rooftop	Dwellings	Public centres	Car parking	Industrial	Industrial	Farms
	Off-grid applications									On-grid applications							

Source: CIEMAT

## Evolution of Commercial SWT Technology

SWTs have traditionally been used for remote small off-grid applications, this being the bulk of the market both in the developed and in the developing world. Only in the last few years has this trend changed, due to the growth of grid connections from SWTs. The potential market for grid-connected SWTs is accelerating the development of SWT technology as the anticipated large-scale production justifies the higher financial investments required for development of the technology.

### ISOLATED APPLICATIONS

As mentioned above, most of the existing systems that include SWTs are isolated applications, as this has been the most traditional use for them. Among the possible isolated applications, the most common are rural electrification, professional applications (telecommunications and so forth) and pumping.

From the technological point of view, three groups of isolated applications using SWT can be distinguished; these are described in the following sections.

#### Very Small Systems

Very small systems usually have a generating capacity smaller than 1 kW. The best-known applications for these configurations are mobile applications, such as boats and caravans, and wind home systems (WHSs), the wind version of solar home systems (SHSs) used for rural electrification. This configuration is based on DC connection, where the battery (usually a lead-acid battery) is the main storage and control component. Usually the system supplies DC loads, as the consumed energy is very low. In terms of number of systems, this is the most frequently used configuration. Manufacturers include Marlec, Ampair and Southwest.

#### Hybrid Systems

The term 'hybrid' has different meanings in the context of off-grid systems with renewable energy. In this case, 'hybrid systems' refers to systems including wind generation and other generation sources (usually photovoltaic, PV). The power generation capacity for this configuration is in most cases less than 50 kW. A diesel generator (gen-set) is used in many systems in this configuration to supply backup power. Traditionally, these systems have also been based on DC connection (Proven, Bornay, Windeco), with a battery (lead-acid in most cases) also playing the role of storage and control, and an inverter to generate AC power for the loads (common practice is to use only AC loads in this configuration). However, in recent years some solutions have been proposed using AC connection. This solution has been possible through the development of bidirectional converters (SMA, Conergy, Xantrex) that allow the flow from the DC bus to the AC bus and vice versa using only one stage of power electronics. Developers using this second solution have proposed the use of SWTs with asynchronous generators directly connected to the AC bus (SMA, Conergy), which was a concept rarely used for these systems (except for Vergnet). The trend of technology for these systems is mainly in the development of modular and flexible power electronics able to provide both the power quality and the supervisory control of the system.

#### Wind-Diesel Systems

Even though some hybrid systems include only wind and diesel generation, the configuration described as 'wind-diesel' (W/D) refers to those systems where the gen-set plays a key role, not only as a backup source but also as an essential component for the correct control and functioning of the system. This configuration is typical for larger isolated applications (>50 kW), and some systems in the MW range have been reported. The storage system this

configuration uses (if any) is a short-term storage one, commonly batteries or flywheels, which is used for power quality and control purposes only, not for long-term energy balance.

Three different types of wind-diesel systems can be distinguished, according to the proportion of wind use in the system:

1. low penetration W/D systems, which do not require additional modifications to the diesel-only grid (usually an existing system) as the diesel engine runs continuously and its controls can cope with the control of the system in the W/D mode of operation without significant modification;
2. medium penetration W/D systems, which require the inclusion of some control capabilities (usually the regulation of deferrable loads or the regulation of the wind generation) for the moments when wind generation is higher than load consumption; and
3. high penetration W/D systems, which require the addition of complex control strategies and devices in order to guarantee the stability of the system in the wind-only mode (in other words when the diesel gen-set has been shut off).

Low penetration systems can be found at the commercial level, whereas solutions for high penetration W/D systems are at the demonstration level. Technology trends for this configuration include the development of robust and proven control strategies. Prospects for this configuration (mainly for high penetration W/D systems) are very promising, as the cost of fuel has recently increased dramatically.

### **GRID-CONNECTED APPLICATIONS**

Another market with great potential for SWTs is in grid-connected applications for residential, industrial or even, lately, urban environments. The so-called distributed wind applications are poised for rapid market growth in response to continuing energy price increases and increased demand for on-site power generation. However,

in order for distributed wind to reach its mainstream market potential, the industry must overcome several hurdles, primarily in system costs, quality of design, grid interconnection and installation restrictions.

Presently, the major share of development of this market is in the US, Canada and Australia, in parallel with new trends in the development of distributed generation systems. This emerging market provides a new impulse to the development of SWT technology.

Wind power can also be used to generate electricity in an urban environment. This trend has mainly been seen in Europe, where the integration of SWTs in the built environment is being actively discussed. New wind turbines are under development for this application, which is looking mainly for quiet and efficient devices under turbulent and skewed wind flow. As well as the installation of wind turbines around and on buildings, there is also interest in 'building-integrated' wind turbines, where the turbine is part of the building structure or façade.

## **Market Development**

### **ISOLATED SYSTEMS**

The following description of the development of the market for isolated systems follows the above divisions under 'Isolated applications'. The market for very small systems represents the most active sector for wind off-grid systems, especially due to the boat and caravan market (thousands of units per year). The use of WHSs for rural electrification is far from the generalised use of SHSs, but some current developments can be noted. For example, the use of WHSs is a traditional practice in Inner Mongolia, where around 250,000 SWTs (adding up to 64 MW) have already been installed, with a manufacturing capability of 40,000 units per year. Apart from this huge local market, another interesting project is PERMER (Renewable Energies for Rural Electrification) in Argentina, where, after a pilot phase of 115 WHSs, an implementing

phase of 1500 WHSs (in two configurations, 300 or 600 W) has been approved.

The market for hybrid systems is widely spread in single system configurations throughout the world. Experiences of planned global rural electrification programmes that include hybrid systems are:

- China, where wind/PV hybrid stations were included as an option, with the participation of some of the existing hybrid systems' developers and manufacturers (such as SMA and Bergey); and
- the Rural Electrification Program in Chile, which included hybrid systems mainly for small islands; this programme is still running, and some systems are still being developed.

Finally, the market for W/D systems is closely related to the cost of producing power with diesel engines. As mentioned above, the recent fuel price increases open a new era for this solution. There is experience with W/D systems all over the world, with Alaska, Canada and Australia as the main near-term markets, ranging from low penetration to high penetration systems. Until now, high penetration W/D systems have been installed mainly in cold climates, where the surplus energy can be used for heating. Chile has also included the W/D systems solution in its electrification programme.

## GRID-CONNECTED SYSTEMS

Different markets exist in the world for small wind turbines, depending mainly on the current state of development of the country and household characteristics, as affected by the residential or built environment.

Europe has an extensive electric grid, so there is little need for off-grid wind energy systems. However, there is some potential for small grid-connected systems, which many Europeans would find attractive. The high concentration of population in urban areas provides a great opportunity for on-site distributed generation from wind power by installing small wind

turbines on rooftops, even though the roughness of the urban environment can mean a reduced and more turbulent wind flow. Because of this, distributed generation based on small wind energy in residential and industrial areas is under development, and urban wind integration is an emerging application that seems to help reduce electricity power demand. Some countries have policies for the promotion of these applications.

The UK is the European leader on micro-generation, which includes small wind energy as one of the important contributors to national targets for renewable energy. The British Wind Energy Association (BWEA) claims that it would be possible to install enough micro and small wind turbines by 2020 to generate up to 1200 MW.

Currently in the UK there are nine companies manufacturing 17 commercial small wind turbine models and more than 11 prototypes. Most of these are horizontal axis wind turbines (HAWT), though some are vertical axis wind turbines (VAWT), for installation on or around buildings. The market is very dynamic, with over 3500 micro and small wind turbines installed in 2007 alone, and high expected domestic and export market growth (more than 120 per cent forecast for 2007/2008). The on-grid/off-grid market share ratio was 50:50 in 2007; however, the on-grid market is expected to increase strongly over the next two years. The building-mounted/free-standing market share ratio was 25:75 in 2007.

The BWEA has adopted a standard for performance, safety, reliability and sound emissions by which small wind turbines will be tested in order to be eligible for incentive programmes. Little information on actual as-installed performance is currently available.

Also in the UK, Proven Energy has launched a project called WINDCROFTING™, available to any landowner with a grid connection. In return for a 25-year lease, the landowner will receive rent on turbines installed on their land, and may also buy a subsidised

turbine at the same time to provide electricity. A subsidiary company installs, operates and maintains the SWT.

The Netherlands is conducting studies on SWTs for grid connection:

- in the field of local attitudes, testing turbines for one year, at the end of which the owner will be able to buy the turbine for 50 per cent of the retail price; and
- in the field of actual performance, measuring the performance of 12 SWTs with a maximum power of 5 kW.

Portugal passed a new law in 2007, with feed-in tariffs for micro-generation systems below 3.68 kW, which includes small wind. This new law encourages renewable energy self-consumption, limiting the maximum amount of energy for which a premium price is paid to 4 MWh/year. The first target of the plan is 10 MW, and the duration of the support is 15 years.

Spain is promoting the SWT sector through different initiatives. Currently, the SWT market is covered by three domestic manufacturers, but new manufacturers are working on larger SWT developments and wind turbines for urban environment integration. In addition, a working group has been created inside the Association of Renewable Energy Producers (APPA) devoted to SWT generation issues. The objectives of this working group are twofold:

1. to inform the public about this technology; and
2. to act as the voice of the SWT industry to public and private entities, trying to achieve the necessary favourable conditions for the development of the technology, both from the financial and the legal points of view.

The US is the main market for SWTs, with more than 100,000 in operation in the 90 W to 25 kW size range, totalling more than 35 MW. During 2007, more than 900 SWTs were sold, 98 per cent by US manufacturers. The US SWT market is growing at about 15 to 20 per

cent per year. Rural households are the most frequent applications for small wind systems, with net metering as the principal fiscal incentive as Production Tax Credits (PTCs, the main US support mechanism for grid-connected wind farms) are not available for this technology. By 2009, most US states will require turbines to be Small Wind Certification Council certified in order to be eligible for their incentive programmes.

The Canadian SWT market is also significant, with between 1.8 and 4.5 MW installed, and approximately CA\$4.2 million in annual sales (2005). There are net metering policies in several provinces, and a feed-in tariff of CA\$0.11/kWh available in Ontario. At least 17 manufacturers are based in Canada; these are working on a new product certification programme adapted to Canadian interests from the existing US and UK certification programmes.

### Technology Trends and Recent Developments

Most of the SWTs that are currently deployed around the world have three blades, but there are also models with two, four or more at the micro-scale. Rotor diameter is below 20 m and most of the commercial small wind turbines have a rotor diameter below 10 m. These turbines are mounted typically on 12 to 24 m towers.

For the rotor, technology trends are towards advanced blade manufacturing methods based mainly on alternative manufacturing techniques such as injection moulding, compression moulding and reaction injection moulding. The advantages are shorter fabrication time, lower parts cost, and increased repeatability and uniformity, but tooling costs are higher.

Most of the current SWTs use a synchronous permanent magnet generator based on rare earth permanent magnets as the electromechanical converter, for the following reasons:

- Rare earth permanent magnets are now taking over from ferrite magnets: they have superior magnetic



## 132 WIND ENERGY - THE FACTS - TECHNOLOGY

This analysis has been made for each of the SWT power ranges defined in Table I.6.1.

Table I.6.5. Brief comments have been included for the different sizes of SWT.

### ROTOR

The rotor technology status is summarised in Table I.6.4.

The results for the analyses of the generator and the power electronics used in SWTs are summarised in

### CLAIMED EFFICIENCY

Another aspect in which SWTs are different to large grid-connected wind turbines is the generation efficiency. First, the efficiency for SWTs is not well

Table I.6.4: Rotor and related issues				
	P < 1 kW	1 kW < P < 7 kW	7 kW < P < 50 kW	50 kW < P < 100 kW
<b>Number of blades</b>				
2				
3				
>3				
<b>Type of rotor</b>				
Horizontal (HAWT)				
Vertical (VAWT)				
<b>For HAWT</b>				
Upwind				
Downwind				
<b>Blade material</b>				
Composite				
Wood + epoxy				
Composite + epoxy				
<b>Mechanical overspeed protection</b>				
No control	x	x	x	x
Passive pitch		x	x	-
Active pitch	-	-	-	x
Centrifugal stall		x	x	-
<b>Mechanical maximum power regulation</b>				
No control	x	x	x	x
Autofurl	x	x	x	-
Tilt	x	x	x	-
Stall	-	x	x	x
<b>Rotational speed</b>				
Very high				
High				
Medium				
Low				



Table I.6.5: Generator, power electronics and other comments

	P < 1 kW	1 kW < P < 7 kW	7 kW < P < 50 kW	50 kW < P < 100 kW
<b>Generator</b>				
PMG				
Axial flux				
Radial flux				
Synchronous generator				
Asynchronous generator				
<b>Power electronics</b>				
Charge controller for SWT with PM or synchronous generator				
Parallel regulator (+ dump load)				
Series regulator				
PMG short circuit available				
Maximum power point tracking				
<b>Other comments</b>	Robust designs; Most common range in terms of sales	Lack of inverters for grid connection	Lack of inverters for grid connection	Lack of manufacturers

known, as there is not much information available; second, the values are usually significantly lower than those for large wind turbines. Aerodynamics has something to do with this, but principally, designs for SWTs are not optimised. Figure I.6.1 shows a graph

of manufacturers' claimed efficiencies for SWTs as a function of rated power at rated wind speed.

It should be noted that IEC standards for power curve measurement are not as rigorously applied by SWT manufacturers as they are in the large wind

Figure I.6.1: Claimed efficiency as a function of rated power

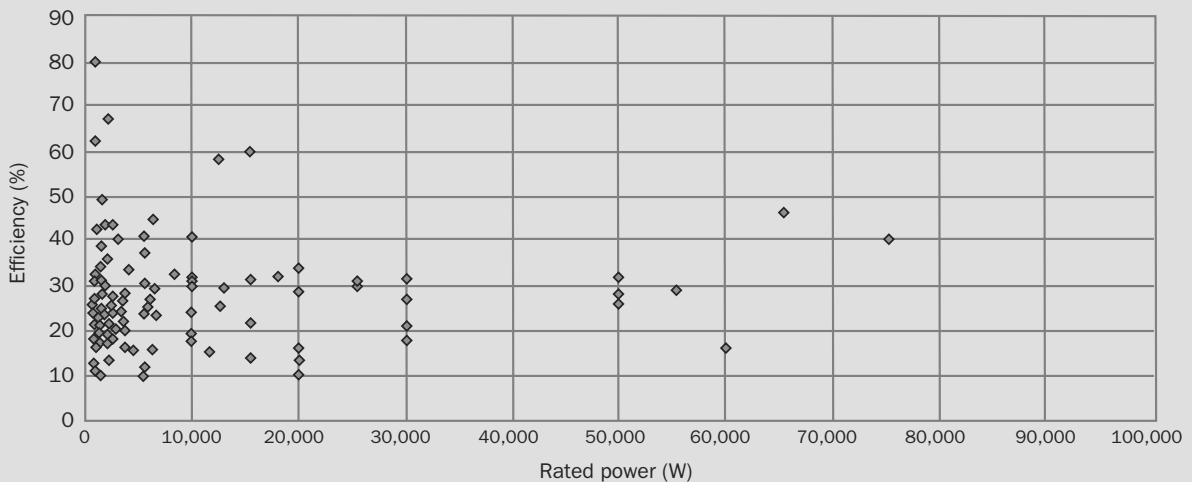

Source: CIEMAT

turbine field, and so comparison is difficult (see Appendix E for further details).

Omitting the models that appear to break the fundamental Betz limit, some comments can be made:

- In general, the efficiency for SWT generation is lower than for large wind turbines (as previously noted, this is in part due to aerodynamics but also due to the lack of optimised designs).
- In reality, the actual efficiencies tend to be even lower (values between 10 and 25 per cent are common).

**COST ANALYSIS**

It is common to use the cost per kilowatt for the analysis of the cost of different generating technologies. For the case of SWTs, the picture obtained is given in Figure I.6.2.

Values are greatly scattered for the low power range, but the trend is that cost per kW diminishes as the rated power increases.

However, an overall cost analysis for SWTs must be preceded by a comment on the definition of the rated power of an SWT. In wind energy generation, there are

no universally accepted standard test conditions (STC is the term used for photovoltaic generation) to which all of the characterisations of the devices are referred. So it is the manufacturer who chooses the conditions (rated wind speed) for which to define the rated power of the SWT. The situation is clarified to some extent in Figure I.6.3, where the chosen rated wind speeds are shown for the different rated power values of the SWT under study.

The large variation in the rated wind speed value means that the specific parameters related to rated power cannot be compared directly, as they do not refer to the same conditions. For large wind turbines there are no defined standard conditions either, but the higher maturity of the market has led to a much lower dispersion.

Another parameter, which is objective, not subjective like rated power, is the swept rotor area. Figure I.6.4 shows the variation of power rating as a function of the diameter.

Even though for higher diameters some dispersion appears, the swept rotor area seems to be a better representation of the power of the SWT than the rated

Figure I.6.2: Cost per kW as a function of rated power

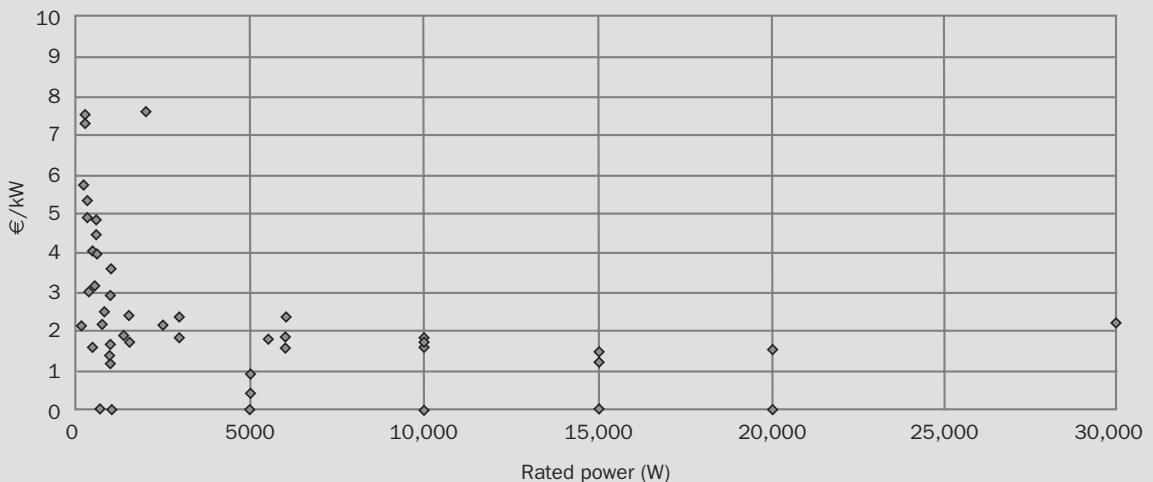

Source: CIEMAT

Figure I.6.3: Comparison of manufacturers' defined rated wind speed and rated power

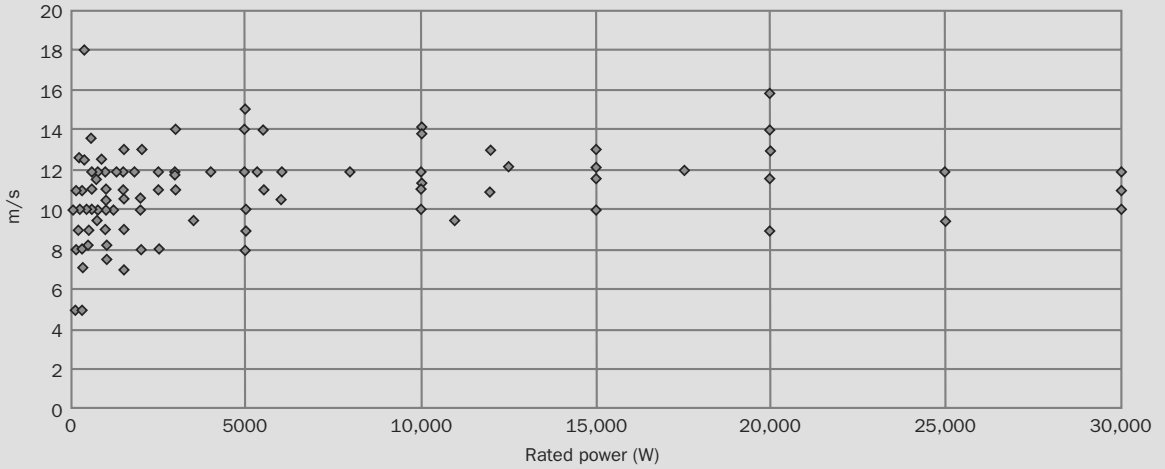

Source: CIEMAT

Figure I.6.4: Manufacturers' defined rated power as a function of rotor diameter

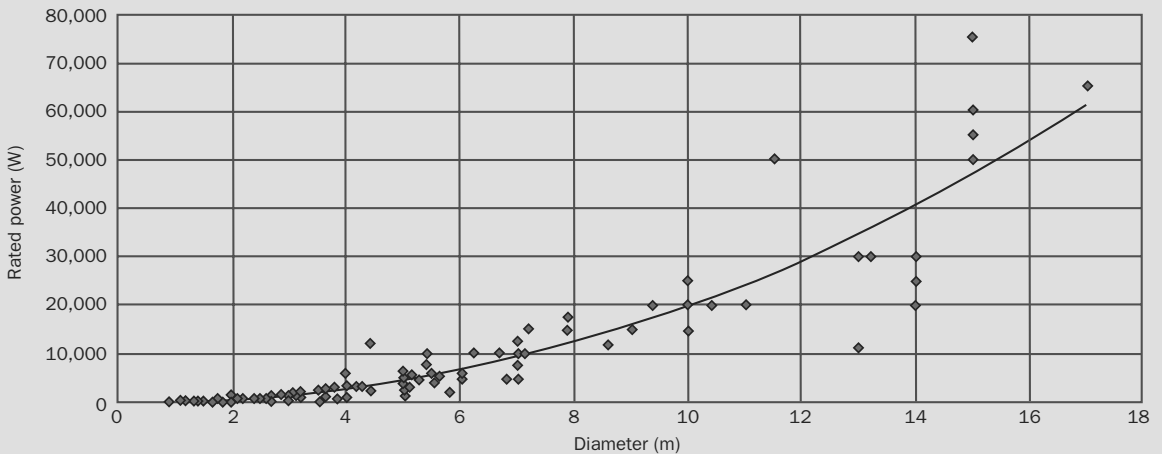

Source: CIEMAT

power itself, and it is definitely more representative of the total energy generated by the SWT. This is also the reason for using cost per square metre, as shown in Figure I.6.5, for the cost analysis.

Even though there is still a significant scattering in the low power range, which is a sign of lack of maturity of the market, the trend of lower costs per square metre is maintained as the size of the SWT increases,

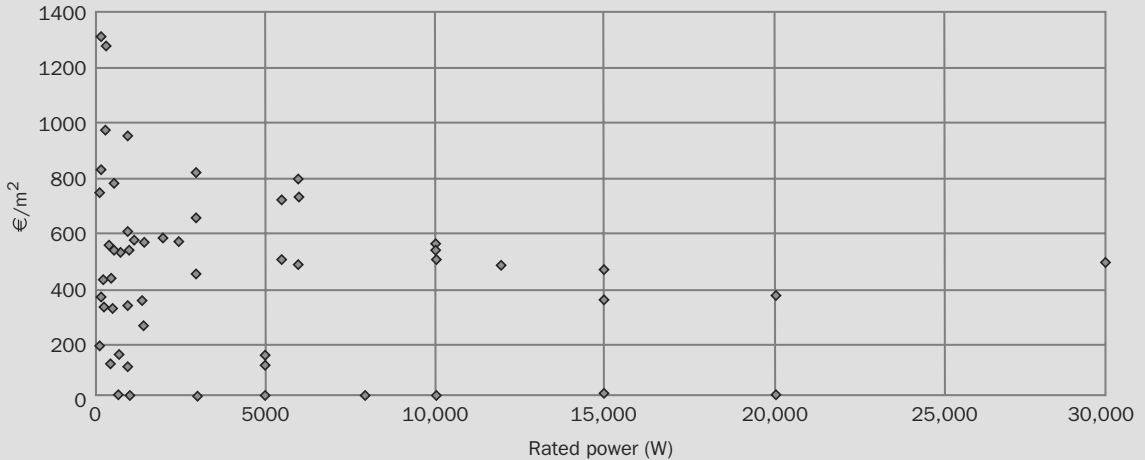
Figure I.6.5: Cost per m<sup>2</sup> as a function of rated power

Source: CIEMAT

which is an advantage when compared with PV generation, a direct competitor for SWTs.

## Future Trends

Future trends are outlined in the following sections.

### BLADE AND ROTOR DESIGN

- new aerofoil design:
  - Improved aerofoil shapes, variable chord distributions and variable twist distributions, such that the overall performance of the SWT can be improved significantly.
  - Noise emission reduction. Noise is still a constraint on the further expansion of wind energy in certain countries. The current trend towards integrating SWTs closer to populated areas and on buildings enhances this problem. Several design parameters can change, such as aerofoil shape, tip speed and angle of attack, but modifying design parameters always means compromising between noise reduction and optimal performance.
- Low Reynolds number aerodynamics. The Reynolds number is an important parameter in fluid mechanics, and tends to be lower for SWTs. Low Reynolds numbers make the problem of aerofoil design difficult because the boundary layer is much less capable of handling an adverse pressure gradient without separation. Thus, very low Reynolds number designs do not have severe pressure gradients, and therefore the maximum lift capability is restricted.
- Deforming blades.
- new materials such as thermoplastics (nylon);
- new SWT regulation methods in order to avoid the use of furling systems. Furling systems are unattractive because of the high acoustic noise emission and vibrations when the SWT furls. New cheap, reliable pitch systems may be developed;
- magnetic bearings to reduce losses in SWTs.

## GENERATOR

- solutions for cogging torque reduction, such as asymmetric poles; and
- low rotational speed SWT, based on hybrid planetary gear and PMG.

## MANUFACTURING SPECIALISATIONS

- blade manufacturers: new methods based on, for example, pultrusion process and filament winding;
- open-use power electronics: power converters capable of working in both stand-alone and grid-connection mode; and
- light tower manufacturing.

## CONCENTRATION OF MANUFACTURERS

### Standardisation, Legislation and Characterisation

- wider use of existing standards;
- further development of standards; and
- commonly accepted means to characterise performance.

## OFF-GRID

- storage technologies;
- improved sizing tools;
- improved understanding of hybrid systems and W/D systems;
- wider offer of components (sizes, manufacturers);
- communication protocols; and
- new applications.

## GRID-CONNECTED

- interconnecting power electronics;
- communication protocols;

- standardised interfaces ('plug and play' devices); and
- simpler, more uniform and better-understood technical requirements of network operators.

## UNDERSTANDING OF WIND RESOURCE IN AREAS WHERE SWT ARE INSTALLED

- near buildings;
- on buildings; and
- within buildings (building-integrated).

## Concluding Remarks and Future R&D Needs

SWTs play an important role in off-grid projects, where in windy locations they can provide a relatively economical power supply, since alternatives such as diesel generators have high fuel costs when used for continuous power supply. This can also be true for grid-connected installations, despite the fact that their production cost per kWh is often higher than that of large wind turbines.

Internationally accepted IEC standards (IEC 61400) relevant to the SWT industry already exist, but are not much used in practice. Some effort is required to develop the existing standards for SWTs, in order to increase their use. For instance, the IEC 61400-2 Standard 'Design requirements for small wind turbines', which applies to wind turbines with a rotor swept area smaller than 200 m<sup>2</sup> and generating at a voltage below 1000 VAC (volts alternating current) is difficult and costly to apply. The power performance standard IEC 61400-12 includes directions for small turbine power performance testing for battery charging, but does not include power performance characterisation for grid-connected SWTs. Finally, while the intent of including noise measurements in the standard rating system is laudable, the test procedure outlined is imperfect.

All components of SWTs – blades, generators, regulation systems, power converters and so on – could be improved.

New designs for integration in the urban environment should be efficient and aesthetic. It goes without saying that they must be extremely quiet and robust.

The market for SWTs is promising. There are an increasing number of SWT manufacturers all over the world, and even manufacturers of large wind turbines are beginning to assess this sector, attracted by the emerging possibilities of the new market.





## I.7 RESEARCH AND DEVELOPMENT

### Introduction

This chapter reviews research and development (R&D) for wind energy, concentrating on programmes and priorities within Europe.

### Added Value of R&D

The wind energy market outperforms its own record every year. Market growth rates are in the same range as those of high-tech technologies (internet, mobile phones and so on). Europe is the world leader in terms of installations and manufacturing, with most of the top ten manufacturers European.

A popular misconception is to consider wind energy as a mature technology where R&D efforts are not necessarily needed. As a result, there is a risk of progressive loss of European leadership, as demonstrated by recent trends in the wind industry:

- High demand has increased wind turbine delivery time and the prices of raw materials such as steel and copper have increased in recent years, meaning that the cost of wind turbines has increased.
- Although most wind turbine manufacturers are still European, two Chinese companies (GoldWind and Sinovel) and one Indian company (Suzlon) have entered the market.

In parallel, the European target of 20 per cent of energy production from renewable sources raises new challenges. In its recently published Strategic Research Agenda<sup>1</sup>, the European Wind Energy Technology Platform, TPWind, proposed an ambitious and feasible vision for Europe. In this vision, 300 GW of wind energy capacity would be delivered by 2030, representing up to 28 per cent of EU electricity consumption. To implement this vision, an average 10 to 15 GW of additional capacity must be manufactured, delivered and implemented every year in Europe. This is equivalent to more than 20 turbines of 3 MW being installed each working day.

Moreover, TPWind's vision includes a sub-objective of offshore wind energy representing some 10 per cent of EU electricity consumption by 2030. It proposes an intermediate step of the implementation of 40 GW by 2020, compared to 1 GW installed today.

In this context, R&D is needed on two fronts:

1. an efficient implementation of the TPWind vision for wind energy, supporting the implementation of European targets; and
2. ensuring European leadership for the long term, through technological leadership.

### Priority R&D Areas in Wind Energy

TPWind has established R&D priorities in order to implement its 2030 vision for the wind energy sector. Four thematic areas have been identified:

1. wind conditions;
2. wind turbine technology;
3. wind energy integration; and
4. offshore deployment and operation.

In order to implement the 2030 vision and enable the large-scale deployment of wind energy, the support of stable and well-defined market, policy and regulatory environments is essential. The following areas are considered:

- enabling market deployment;
- cost reduction;
- adapting policies;
- optimising administrative procedures;
- integrating wind into the natural environment; and
- ensuring public support.

### WIND CONDITIONS

Current techniques must be improved so that, given the geographic coordinates of any wind farm (flat terrain, complex terrain or offshore; in a region covered by extensive data sets or largely unknown), predictions with an uncertainty of less than 3 per cent can be made.

Three main research objectives – resource, design conditions and short-term forecasting – are being supported by six research topics, identified by TPWind:

1. **Siting of wind turbines in complex terrain and forested areas**, in order to accurately calculate the external wind load acting on a wind turbine, and its lifetime energy production.
2. Improving the understanding of **wakes inside and between wind farms**, and using this knowledge in the design and financial analysis of offshore wind projects. The specific objectives are to increase the availability of data sets from large wind farms, improve models to predict the observed power losses from wakes and evaluate the downwind impacts of large wind farms, especially offshore.
3. **Offshore meteorology**: improving the knowledge and understanding of processes in offshore conditions. This will be used to develop new models and to extend existing ones. This is necessary in order to develop methods for determining the external design conditions, resource assessment and short-term forecasting.
4. **Extreme wind speeds**: producing a worldwide extreme wind atlas, including guidelines for the determination of the 50-year extreme wind speed and extreme statistics.
5. Investigating and modelling the behaviour of the **wind profile above 100 m**, through models, measurements and theoretical tools describing the wind profile in the entire boundary layer.
6. **Short-term forecasting** over a timeframe of one or two weeks for wind power prediction and electricity grid management.

## WIND TURBINE TECHNOLOGY

The aim is to ensure that by 2030, wind energy will be the most cost-efficient energy source on the market. This can only be achieved by developing technology that enables the European industry to deliver highly

cost-efficient wind turbines, and adequate grid infrastructure and changed grid operation procedures.

Research topics are categorised according to the technical disciplines and cross-sector criteria on which the integral design and operation of wind power systems are based. The seven research areas are:

1. **The wind turbine as a flow device**. With the increasing size and complexity of wind turbines, a full understanding of aerodynamic phenomena is required, including external conditions, such as the wind speed distribution on the rotor plane, for different wind turbine configurations and sites.
2. **The wind turbine as a mechanical structure/materials used to make the turbine**. The goal is to improve the structural integrity of the wind turbine through an improved estimation of design loads, new materials, optimised designs, verification of structural strength, and reliability of components such as drive trains, blades and the tower.
3. **The wind turbine as an electricity plant**. This should develop better electrical components, improve the effect of the wind turbine on grid stability and power quality, and minimise the effect of the grid on wind turbine design.
4. **The wind turbine as a control system**. This will aim to optimise the balance between performance, loading and lifetime. This will be achieved through advanced control strategies, new control devices, sensors and condition monitoring systems.
5. **Innovative concepts and integration**. This should achieve a significant reduction in the lifetime cost of energy by researching highly innovative wind turbine concepts. With the support of an integrated design approach, this will be made possible through incremental improvements in technology, together with higher risk strategies involving fundamental conceptual changes in wind turbine design.
6. **Operation and maintenance strategies**. These become more critical with up-scaling and offshore deployment of wind power systems. The objective



is to optimise O&M strategies in order to increase availability and system reliability.

7. **Developing standards for wind turbine design.** This is to allow technological development, whilst retaining confidence in the safety and performance of the technology.

## WIND ENERGY INTEGRATION

Large-scale integration of wind power at low integration costs requires research in three main areas:

1. **Wind power plant capabilities.** The view is to operate wind power plants like conventional power plants as far as possible. This approach implies fulfilling grid code requirements and providing ancillary services. It requires investigating the wind power plant capabilities, grid code requirements and possible grid code harmonisation at the EU level.
2. **Grid planning and operation.** One of the main barriers to the large-scale deployment of wind technology is limited transmission capacity and inefficient grid operation procedures. The grid infrastructure and interconnections should be extended and reinforced through planning and the early identification of bottlenecks at the European level. A more efficient and reliable utilisation of existing infrastructures is also required. Review of the existing rules and methodologies for determining transmission capacity is needed. Further investigation is required for offshore to assess the necessity of offshore grids. Dynamic models are needed to assess the influence of wind generation on power system operation, such as a more coordinated supervision scheme and a better understanding and improved predictability of the state of the power system.
3. **Energy and power management.** Wind power variability and forecast errors will impact the power system's short-term reserves. At higher wind power penetration levels, all sources of power system

flexibility should be used and new flexibility and reserves sought.

Additional possibilities for flexibility must be explored, by both generation and demand-side management, together with the development of storage. In the context of variable production, variable demand and variable storage capacity, probabilistic decision methods should be promoted.

Also, a more centrally planned management strategy would mean that available grid capacities could be used more effectively and reinforcements could be planned more efficiently. The emphasis should be put on developing good market solutions for the efficient operation of a power system with large amounts of renewable generation.

## OFFSHORE DEPLOYMENT AND OPERATIONS

The objectives are to achieve the following:

- coverage of more than 10 per cent of Europe's electricity demand by offshore wind;
- offshore generating costs that are competitive with other sources of electricity generation;
- commercially mature technology for sites with a water depth of up to 50 m; and
- technology for sites in deeper water, proven through full-scale demonstration.

Five research topics have been prioritised by the European wind energy sector:

1. **Substructures.** These represent a significant proportion of offshore development costs. It is necessary to extend the lifetime of structures, reduce costs and develop risk-based life-cycle approaches for future designs. Novel substructure designs, improved manufacturing processes and materials are critical. In the near term, the major deployment issue is the development of the production facilities and equipment for manufacturing the substructures.

This will require significant investment in new manufacturing yards and in the associated supply chain. Further data are needed on the behaviour of existing structures, supporting research into improved design tools and techniques, and better design standards.

2. **Assembly, installation and decommissioning.** This must solve the challenge of transferring equipment to wind farm sites. Such transfer requires efficient transport links, large drop-off areas and good harbours. The second challenge of wind turbine installation will require specially designed vessels and equipment. Safe, efficient and reliable processes must be developed that are easy to replicate. Finally, techniques should be developed for the dismantling of offshore wind farms and for quantifying the cost of doing so.
3. **Electrical infrastructure.** The manufacturing and installation of electricity infrastructure represents a significant cost in offshore developments. The full potential of offshore wind can only be realised through the construction of interconnected offshore grid systems and regulatory regimes that are better able to manage the variability of wind power generation. This will require significant investment in cable equipment and in vessels.
4. **Larger turbines.** The economics of offshore wind favour large machines. The key factors affecting the deployment of offshore wind are the current shortage of turbines and their reliability. New designs might be developed that address the challenge of marine conditions, corrosion and reliability issues. The development of testing facilities is a crucial issue.
5. **Operations and maintenance (O&M).** Strategies that maximise energy production while minimising O&M costs are essential. Better management systems and condition monitoring systems will be required. Effective access systems will be essential for the operation of the offshore facilities and the safety of personnel involved.

In addition to the five research topics, there are three common themes that underpin each of these topics and that are critical to delivering an offshore wind industry in Europe that is a world leader. These are:

1. **Safety.** Safe operation of offshore facilities and the safety of the staff involved are vital. It requires the examination and review of turbine access systems, and escape and casualty rescue.
2. **The environment.** This covers two main areas:
  - i. The construction of substantial infrastructure in the seas around Europe must be done responsibly with minimal adverse ecological impacts; and
  - ii. More knowledge about the offshore environment is needed, including collecting and understanding climatic, meteorological, oceanic and geo-technical data.
3. **Education** is critical for delivering safety. Moreover, more trained people with the necessary skills to develop the industry are needed. These will range from skilled workers needed to manufacture, build and operate the facilities to graduates that understand the technical, commercial and social context of the industry.

## Market Deployment Strategy

The market deployment strategy developed by the European wind energy sector under the framework of TPWind is outlined in 'Priority R&D areas in wind energy'.

## ENABLING MARKET DEPLOYMENT

Thematic priorities on these aspects are:

- **Removing electricity market barriers** by implementing market rules that promote demand-side management and flexibility and that provide much shorter gate closure times to reduce balancing costs. Improved forecasting tools, such as tools for developing assumptions on future market fluctuations in order to secure investments. In these

integrated markets – at both local and international levels – wind power should be considered as an adapted market commodity that is tradable, exchangeable and transparent, like other forms of energy. The market impacts of a large penetration of wind energy on the current electricity markets should be evaluated.

- **Securing revenues** by developing a stable market with clear wind power objectives and stable incentive schemes. Markets should make use of all possible power system flexibility to keep imbalance costs low. This includes markets for ancillary services, such as bringing virtual power plants to the market, and effective balancing markets.
- **Creating a level playing field** by integrating wind power's positive externalities, such as contribution to energy independence and climate change mitigation. This would lead to recognition that wind energy deserves to be categorised as a public interest investment that is largely independent of fuel prices and has very low external costs.
- **Adapting the grid infrastructure** to make wind as manageable and as cost-efficient as possible for network operators. One approach is for wind power plants to be operated, as far as possible, like conventional power plants, to develop the electricity grid infrastructure needed, to implement common market policies and align existing markets, to develop large-scale energy storage solutions, demand-side management, and to adapt grid codes.
- **Removing policy and administrative barriers to grid development** through strategic planning, strong political leadership and adapted consenting processes.

## COST REDUCTION

In the past few years, energy demand has gone up significantly and the price of fossil fuel has increased. In the case of wind energy, after a period in which

costs decreased in line with experience, there has recently been an increase in wind energy costs due to very high global demand and rising commodity prices.

Other reasons for the rising costs include the increase in the overall price of materials and supply chain bottlenecks. The wind energy sector and policy-makers should focus on reducing the cost of investment, which would lead to reductions in the lifetime cost of energy, making wind more competitive. These priorities are:

- **Investment costs.** These are influenced by bottlenecks in the supply chain, which limit the effects of economies of scale on costs. Moreover, due to high demand, logistics and service suppliers will also suffer from supply bottlenecks, leading to higher investment costs. Uncertainties remain regarding the future cost of raw materials and the subsequent impact on the cost of wind energy. Finally, as installed capacity increases, wind power will move to more challenging environments, needing technological improvements to reduce costs.
- **Operating costs.** These account for a significant proportion of the overall lifetime costs. They can be reduced substantially by improving reliability, optimising operational services and component supply, and developing specific offshore systems.
- **The cost of capital.** This is closely linked to the financial sector's confidence in the technology, future revenue and market sustainability. Reducing exposure to risk in different categories will in turn reduce the cost of capital.

## ADAPTING POLICIES

In order for wind energy markets to develop further, ambitious wind energy targets need to be set and appropriate measures taken in the EU Member States. Policy has to be consistent, stable and long-term, to allow for the most efficient investment and cheapest electricity for the consumer.

Long-term, legally binding wind and renewables targets should be implemented at national level, and a breakdown for the power, heat and transport sector is recommended. Penalties should be imposed on Member States that do not comply with the national targets or action plans. Stable and long-term support schemes are essential.

### **OPTIMISING ADMINISTRATIVE PROCEDURES**

Key issues exist with the current administration of applications for wind farms and auxiliary infrastructures in many parts of Europe. These include inconsistencies and uncertainties in the requirements and judgements of administrative authorities and delays in the consenting process.

Despite policies supporting wind energy at European and national levels, it is difficult to obtain planning permits in many Member States. In some Member States, there is a lack of clarity on the administration requirements and processes for wind farm applications, particularly in relation to applications for repowering existing wind farms. Repowering projects create new challenges over and above those of developing new wind farms on a site.

### **INTEGRATING WIND POWER INTO THE NATURAL ENVIRONMENT**

In extreme cases, wind farm projects are rejected by consenting authorities because of minor adverse local effects, as their positive impact on the global environment is not considered.

At present, environmental impact assessments (EIAs) are inefficient and the results of EIAs are not widely disseminated. A consensus has yet to be reached on whether EIAs could use studies that have already been carried out, rather than doing full and separate studies each time an EIA is performed.

The results of existing environmental monitoring across Europe need to be centrally gathered and reviewed in order to identify existing gaps in knowledge for future research.

Post-operational monitoring is currently not comprehensively evaluated against the areas of the EIA. The results are rarely shared widely or referenced in future assessments. As a consequence, much of the value of post-operational monitoring is not realised.

Priority development zones should be identified for the strategic planning of wind farms, as a policy priority.

### **ENSURING PUBLIC SUPPORT**

Compared to conventional sources of energy generation, wind energy is popular with the general public. The industry can help to sustain this by further implementing best practices based on public consultation; by remaining willing to address public acceptance issues; and by demonstrating improvements that reduce or mitigate impacts of public concern.

Whilst there is large-scale support for wind energy, wind farm applications can be delayed or blocked by real or perceived resistance from communities at the local level.

It is essential to involve local communities in the process of wind farm developments in their area, and to ensure that they also reap some benefits. Decision-makers need to be kept well informed of the real level and nature of public support, not just the perceived level.

### **R&D Funding for Wind Energy**

Wind energy contributes to the priorities set out by the Lisbon Strategy (2000). This strategy sets European Union goal of becoming 'the most competitive and dynamic knowledge-based economy in the world, capable of sustainable economic growth with more and better jobs and greater social cohesion' by 2010.

These objectives were complemented in 2002 at the Barcelona European Council, where Heads of State agreed that research and technological development (RTD) investment in the EU must be increased with the aim of reaching 3 per cent of GDP by 2010, up from 1.9 per cent in 2000 (1.84 per cent in 2006 for EU-27).

If the Barcelona 3 per cent objective is to be fulfilled, wind energy R&D investment would have to represent an average of €430 million per year. Two-thirds of this budget should be invested by the private sector and one-third by the public sector.

Average public annual support would then be €143 million per year. If 50 per cent of this support is provided by national (Member State) programmes and 50 per cent from EC programmes, the average contribution from the EC and from the national programmes should each be €72 million per year and increase with market turnover. The following section investigates past and current funding levels for wind energy R&D.

## SUPPORT AT EC LEVEL

Historically, research and development funding for wind energy and other renewable energy technologies has been a fraction of the funding for conventional energies. According to the IEA, over the period from 1974 to 2002, nuclear energy research financing was approximately three and a half times greater than that dedicated to renewable energy. The technology achievements in wind energy are even more impressive given that the sector has received a mere 1 per cent of energy research funding in the IEA countries in 1974–2002. In the same period, nuclear energy received 58 per cent or US\$175 billion, and fossil fuels 13 per cent (see Figure I.7.1).

Energy research funding in the EU has decreased dramatically and is currently at one-quarter of the level in 1980, according to the European Commission. Furthermore, the dominant part of EU research funding continues to be allocated to nuclear energy. In its first

Figure I.7.1: Total energy R&D shares in IEA countries, 1974–2002 (US\$)

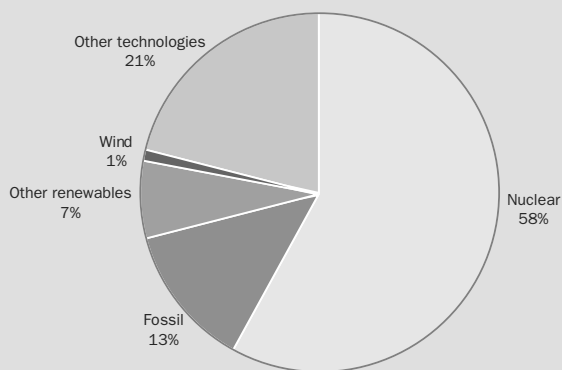

Source: Renewable Energy, Market and Policy Trends in IEA Countries, OECD/IEA (2004) in *Prioritising Wind Energy Research: Strategic Research Agenda of the Wind Energy Sector*, EWEA, July 2004

review of EU energy policies, in September 2008, the IEA called for the EU to change its priorities:

*The current Framework Programme allocates €1.95 billion, or almost 40 per cent of the energy funding, to nuclear fusion, a technology that is only expected to contribute past 2050. It will be important for the achievement of the EU climate change targets that this funding allocation is revised at the earliest possible opportunity, and that funding for non-nuclear energy research and development is increased significantly. (IEA, September 2008)*

The EU FP7 Euratom programme allocates €1947 million to nuclear fusion, €287 million to nuclear fission and €517 million to nuclear research activities of the Joint Research Centre (JRC). In total, EU nuclear energy research funding totals €2.75 billion over the five-year period 2007–2011 or €550 million per year.

Non-nuclear energy research under the EU's FP7 receives €2300 million over the seven-year period 2007–2013, or €460 million per year. Over the next

five years, the average annual EU research budget for energy will be €1010 million, allocated as follows:

- nuclear energy research: €550 million (54 per cent); and
- non-nuclear energy research: €460 million (46 per cent), of which approximately half to renewables and energy efficiency (€230 million – 23 per cent).

How much of the EU non-nuclear energy research budget will go to wind energy is not earmarked, but as shown in Table I.7.1, wind energy received €25 million under FP5 and €32 million under FP6, or approximately 3 per cent of the total FP7 energy research budget.

#### Funding for Overall Non-nuclear Energy (NNE) Research

In 2005, the European Commission's Advisory Group on Energy released a report<sup>2</sup> that demonstrated the full extent of the reduction in European Union funding for energy R&D through its Framework Programmes.

Regarding FP6, the Strategic Working Group of the Advisory Group on Energy pointed out that:

*in face value terms, expenditure is now less than it was 25 years ago, in real-value terms it is very*

*much less and as a percentage of the total Community R&D it is roughly six times smaller.*

Two years later, the Strategic Energy Technology Plan (SET-Plan) was adopted. Again, it was pointed out that:

*Public and private energy research budgets in the EU have declined substantially since peaking in the 1980s in response to the energy price shocks. This has led to an accumulated under-investment in energy research capacities and infrastructures. If EU governments were investing today at the same rate as in 1980, the total EU public expenditure for the development of energy technologies would be four times the current level of investment of around EUR 2.5 billion per year.*

This state of affairs is illustrated in Figure I.7.2, showing that energy research funding as a percentage of all EU R&D funding has reduced from 66 per cent in FP1 to around 12 per cent in FP6 and 7 per cent in FP7.

#### Funding for Renewable Energy Research

Under FP6, €810 million was dedicated to R&D under the 'Sustainable energy systems' chapter (€405 million

Table I.7.1: EC funding levels in FP5 and FP6

Wind Technology paths (strategically important areas and topics)	EC funding in					
	FP5			FP6		
	Number of projects	Eligible costs in €m	Total EC contribution in €m	Number of projects	Eligible costs in €m	Total EC contribution in €m
Large size wind turbines	10	27.68	14.98	4	37.95	19.46
Integration and managing of wind power	7	12.99	7.15	4	7.75	4.43
Wind farm development management	3	4.02	2.23	2	34.03	7.70
Total wind	20	44.69	24.36	10	79.74	31.59

Source: European Commission, DG Research, *The State and Prospects of European Energy Research Comparison of Commission, Member and Non-Member States – R&D Portfolios*

Figure I.7.2: Energy spending in the seven Framework Programmes

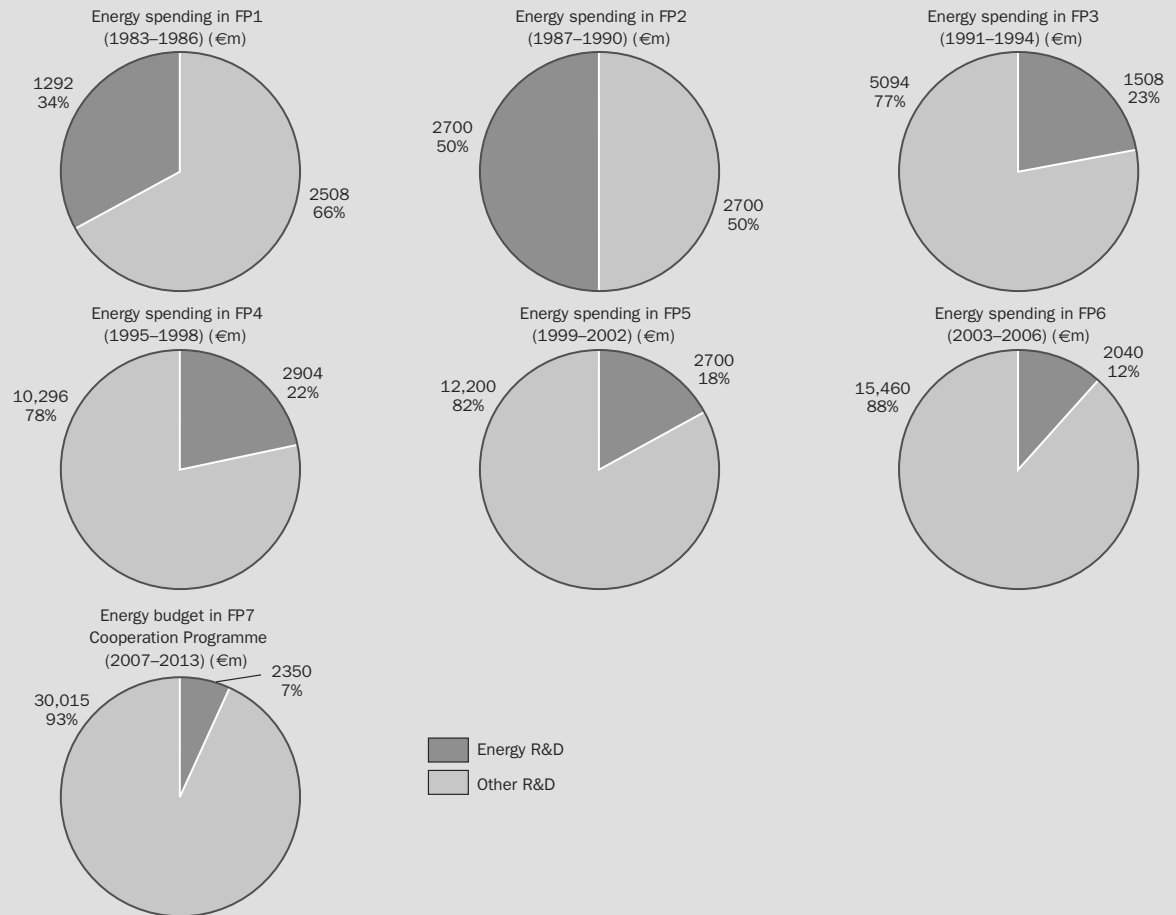

Source: *Strategic Research Agenda: Market Deployment Strategy from 2008 to 2030*, European Wind Energy Technology platform, July 2008 based on data from the European Commission, DG Research

to long-term R&D, administered by DG Research, and €405 million to short- to medium-term research, administered by DG TREN). This represented a reduction of some 20 per cent from FP5.

The name of the chapter or budget-line, ‘Sustainable energy systems’, engendered a lack of transparency in the funding process. The chapter included, for example, ‘clean coal’ technologies, focusing mainly on the sequestration of CO<sub>2</sub>. It also included hydrogen and fuel cells, which are not energy sources.

For FP7, the lack of transparency still remains. The €2.35 billion budget available for non-nuclear energy under the Cooperation Programme includes the following chapters:

- hydrogen and fuel cells;
- renewable electricity generation;
- renewable fuel production;
- renewables for heating and cooling;
- CO<sub>2</sub> capture and storage technologies for zero emission power generation;

- clean coal technologies;
- smart energy networks;
- energy efficiency and savings; and
- knowledge for energy policymaking.

In 2007 the budget committed to projects was approximately €0.32 billion.

### Funding for Wind Energy Research

The European Commission has provided an analysis of the evolution of the R&D budget over FP5 and FP6. Comparison between FP5 and FP6 is provided in Table I.7.1 on three main aspects:

1. large size wind turbines;
2. integration and management of wind power; and
3. wind farm development and management.

Due to two integrated projects (DOWNWIND and UpWind), the average project size increased significantly between FP5 and FP6. The EC contribution also increased by 27 per cent, reaching €31.59 million, an

average of €7 million per year – one tenth of TPWind requirements.

### SUPPORT FOR WIND R&D AT MEMBER STATE LEVEL

The data discussed below have been sourced from the IEA's Energy R&D Statistics Database. R&D budgets for the period 1974–2005 are available for 19 EU countries: Austria, Belgium, Czech Republic, Denmark, Finland, France, Germany, Greece, Hungary, Ireland, Italy, Luxembourg, The Netherlands, Norway, Portugal, Spain, Sweden, Switzerland and the UK.

Figure I.7.3 illustrates the evolution of total funding for wind R&D during the period 1974–2006 (excluding EC funding). The total available budget peaked in 1985, with a significant budget available in The Netherlands, accounting for 46 per cent of the total.

The total available budget in 2003 was 48 per cent of this peak, decreasing to 37 per cent in 2004 (though for 2004, data from The Netherlands are not available). In 2005, a significant budget increase can be

Figure I.7.3: State R&D funding for wind energy (in € million-2006)

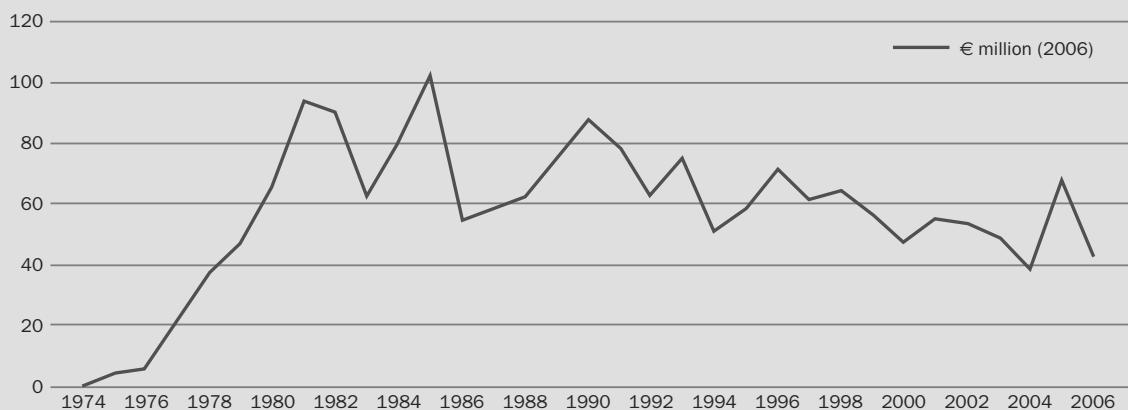

**Note:** For some dates, data are not available for certain countries.

Source: EWEA, based on IEA data



Figure I.7.4: Wind R&amp;D budget evolution for countries with average budget above €3 million/year (1998–2006 in € million-2006)

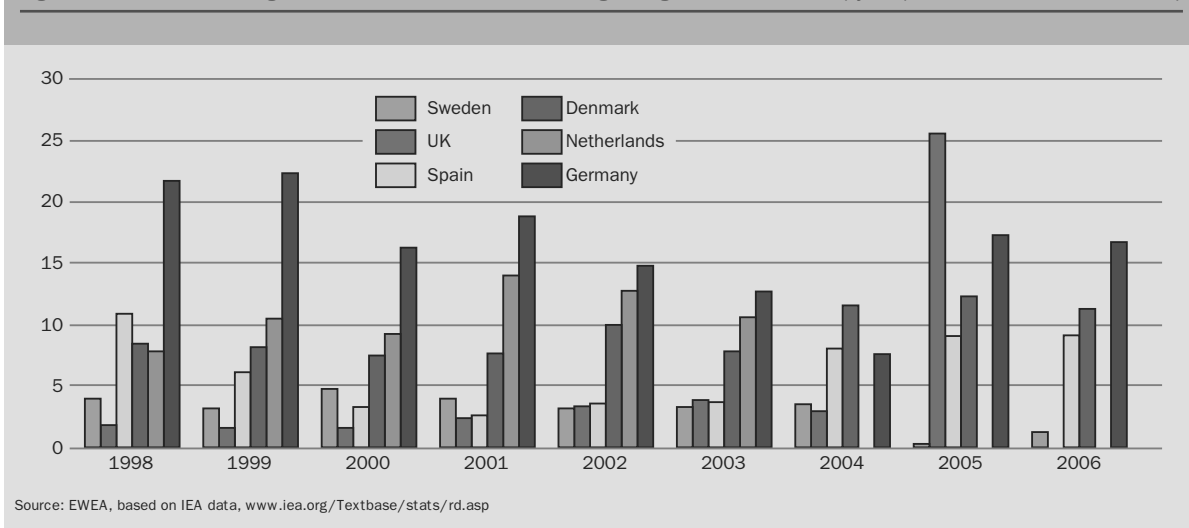

noticed, with the R&D budget in the UK increasing by a factor of 10. In 2006, the total available budget for wind R&D was 41 per cent of the 1985 maximum and 60 per cent of TPWind's requirements.

For the period 1998–2006, these budget variations are highlighted in Figure I.7.4 for the six main contributing countries. Germany was the main contributor to R&D funding for wind energy, which is consistent with its world-leading position in installed wind power capacity and world manufacturing capacity. After a decrease in funding by a third in 2004, Germany made a significant effort in 2005 and 2006. For 2005, the budget contribution of the UK, however, far exceeded any other.

These strong budget variations prevent the sector from relying on the material research support scheme. Ambitious long-term research programmes, involving heavy research facilities, are therefore risky.

Figure I.7.5 shows the average R&D budget for the period 1998–2006 for countries with a significant budget (the seven countries above €1 million on average). Only six of these countries had an average budget that exceeded €3 million a year and only these six main contributors were able to set up research laboratories

and test facilities that were recognised worldwide and/or had world-leading turbine or component manufacturers. These figures clearly demonstrate that a high-quality research structure is built on long-term, high-level R&D budgets.

## CURRENT EFFORT FROM THE PRIVATE SECTOR

Collecting and analysing the available information on R&D investment from wind turbine and component manufacturers is far from straightforward. Some manufacturers merge figures for wind into their overall R&D investment data, while data from other manufacturers is not available for public consultation.

Figures for 2006 are available for some wind turbine manufacturers,<sup>3</sup> making a total of €186 million – 65 per cent of TPWind requirements. This figure does not, however, include all manufacturers or sub-suppliers. The ratio of R&D expenditure to net sales varies significantly, from 0.4 to 3.1 per cent. Clipper Windpower (89 per cent) is an exception, as the manufacturing capacity is located in the US.

## 150 WIND ENERGY - THE FACTS - TECHNOLOGY

Figure I.7.5: Average funding, 1998–2006, for countries with an average budget above €1 million/year (in € million-2006)

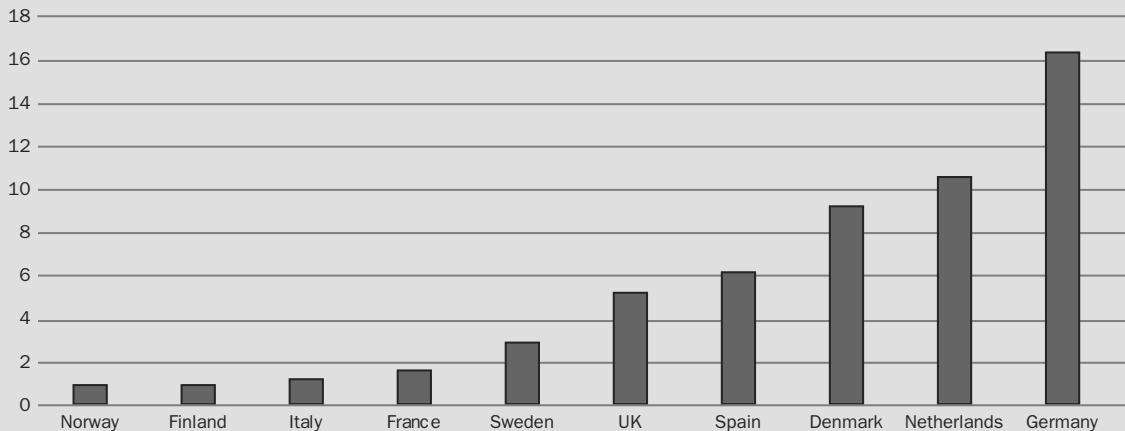

Source: EWEA, based on IEA data, [www.iea.org/Textbase/stats/rd.asp](http://www.iea.org/Textbase/stats/rd.asp) in *Strategic Research Agenda Market Deployment Strategy from 2008 to 2030*, European Wind Energy Technology Programme, July 2008

Table I.7.2: R&D investment by the private sector

Company	Country	R&D Investment	Net Sales	R&D/net Ratio	Sales
		2006 €m	2006 €m	2006 %	2005 %
Acciona	Spain	22.60	6272	0.4	0.1
Gamesa	Spain	33.12	2391	1.4	1.6
Nordex	Germany	11.25	514	2.2	2.9
REpower Systems	Germany	14.02	459	3.1	3.1
Vestas Wind Systems	Denmark	88.60	3854	2.3	2.4
Nordex	Germany	11.25	514	2.2	2.9
Clipper Windpower	UK	5.33	6	88.8	193.0

Source: *Strategic Research Agenda Market Deployment Strategy from 2008 to 2030*, European Wind Energy Technology Programme, July 2008

## CONCLUSION

Wind energy will be a main contributor to the implementation of the EU objectives on renewable energy production. However, the current R&D efforts for wind energy are insufficient – at all levels – to respond to the energy challenges faced by the EU. The risk is therefore of failure in reaching the EU objectives for energy production from renewable sources

(and therefore on reduction of CO<sub>2</sub> emissions) and in implementing the European strategy for growth and jobs.

A critical component is the contribution of the EU, which, in order to achieve the objectives of the Lisbon Strategy, should lead by example. A strong and clear signal from the EU would act as catalyst at Member State level in strongly supporting renewables and wind in particular.

The problem Europe faces is not a lack of technical solutions but a lack of time. 2020 is tomorrow. The longer it takes to adapt the EU energy system, the more difficult and costly it will be, with an unknown impact on the environment.

In 2007, the Strategic Energy Technology Plan set a new agenda for energy research and innovation in Europe, with the core aim of speeding up the deployment progress of energy technologies. One of the proposed key areas of action is that of industrial initiatives, among which is the European Wind Initiative. This initiative should be a major part of European research and innovation in wind energy technology. It should lead to an adapted European energy mix that is less reliant on imports, is based on zero CO<sub>2</sub> emissions and creates employment opportunities.

## Part I Notes

- <sup>1</sup> For more information on this, please visit the TPWind website: [www.windplatform.eu](http://www.windplatform.eu)
- <sup>2</sup> European Commission (2005) *Towards the European Energy Research Area: Recommendations by the ERA Working Group of the Advisory Group on Energy*, 2005, Directorate General for Research, Luxembourg
- <sup>3</sup> European Commission (2007b). *Monitoring Industrial Research: The 2007 EU Industrial R&D Investment Scoreboard*.



