

Television Production Handbook

By
Roger Inman
Greg Smith

Television Production Handbook

**By
Roger Inman
Greg Smith**

©1981-2006 Roger Inman & Greg Smith. All rights reserved.

Television Production Manual

INTRODUCTION

There are essentially two ways of doing television. Programs are shot either in a specially designed television studio using several cameras which are fed into a control room and assembled in "real time," or they are shot using a single camera on location and assembled later in an editing room or on a computer. Obviously, almost all non-professional video is shot using a single camera. That makes it what the pros call "electronic field production," or EFP.

In electronic field production, the director is like a composer of music, creating and assembling images and impressions, fitting them together carefully, weighing the quality and importance of each as he goes. He works much as a film director would, in a linear fashion from one shot to the next, one scene to the next. He is dealing with only one picture and one situation at a time. Since the program will be edited later, he can shoot out of sequence, repeat shots, and record extra shots to be included later. Electronic field production allows for a richness of scene and artistic creativity born sometimes out of necessity and sometimes out of opportunities suggested by the location itself.

Professionals spend most of their time planning, scripting, and organizing their productions. The amount of time spent actually recording the program is surprisingly short compared to the time spent preparing for it. Each program goes through several important stages, from development of the concept through planning and scripting, then on to set design or location scouting, acquisition of performers and rehearsal. Along the way, the producer schedules his equipment, finds a competent crew, and brings all of the necessary elements together for actual production of the program.

Television is an amalgam of many diverse disciplines. Professional productions often depend on the skill and cooperation of many people, as well as the ability of the producer and director to bring these people together in a cooperative effort. On the other hand, with digital technology, it is also possible to be a "one man band," performing all of the various functions yourself, and produce a "broadcast quality" program. While this book will deal with many of the techniques of production, it doesn't pretend to tell you how to

Television Production Manual

do anything. After all, rules are made to be broken. Or ignored. Still, picking the mind of a professional television producer will help you get better results every time you pick up a camera.

Television Production Manual

Contents

THE CAMERA	1
LENS CONTROLS 1	
<i>Iris</i>	2
<i>Zoom</i>	2
<i>Focus</i>	3
ELECTRONIC CONTROLS 4	
<i>Pedestal</i>	4
<i>Gain</i>	4
<i>White Balance</i>	4
<i>Viewfinder</i>	4
TELEVISION LIGHTING	5
LEVEL 5	
ABSOLUTE ROCK BOTTOM 5	
CONTRAST 6	
COLOR TEMPERATURE 7	
LIGHTING TECHNIQUES.....	11
<i>Key Light</i>	11
<i>Back Light</i>	12
<i>Fill Light</i>	12
<i>Background</i>	12
MOVEMENT 13	
CROSS LIGHTING 13	
LIGHTING FOR DANCE 14	
HIGH CONTRAST 14	
LIMBO 14	
BACK LIGHTING 15	
APPLICATION 15	
LIGHTING AND IMAGE RESOLUTION 16	
THAT “HOMEY LOOK” 16	
COMPOSITION AND CAMERA MOVEMENT	19
COMPOSITION 19	
CAMERA MOVEMENT 27	
BASIC AUDIO	31
TECHNICAL TERMINOLOGY 31	
EQUIPMENT 33	
PRODUCTION TIPS 38	
BASIC VIDEO	41
NTSC VIDEO 41	

Television Production Manual

DIGITAL VIDEO	47
VIDEO SOURCES	48
MONITORING	53
<i>Vectorscope</i>	54
<i>Meters</i>	54
<i>Switching</i>	55
ORGANIZATION OF MATERIALS	57
ADDITIONAL VIDEO	61
TITLES AND ARTWORK	61
<i>Character Generator</i>	62
<i>Live Cards</i>	62
<i>Slides</i>	63
<i>Film</i>	64
<i>Computers</i>	64
RIGHTS AND RESPONSIBILITIES	67
PEOPLE ON CAMERA	67
COPYRIGHT	70
EDITING AND PROGRAM CONTINUITY	73
WS - MS - CU SEQUENCES; USING CLOSE-UPS	75
JUMP CUTS AND THE THIRTY DEGREE RULE	76
<i>The Thirty-degree Rule</i>	77
DIRECTION OF MOTION AND THE 180 DEGREE RULE	78
CUTAWAYS AND INSERTS	79
SHOT TIMING AND PACING	81
CUTTING SOUND	81
VIDEOTAPE EDITING	82
<i>Tape to tape editing</i>	83
<i>Editing modes:</i>	83
<i>The Control Track:</i>	84
<i>SMPTE Editing:</i>	84
COMPUTER EDITING	85
<i>Analog Video Capture</i>	86
<i>Digital Capture</i>	89
GETTING THE WORD OUT.....	91
VIDEOTAPE	91
CD	91
DVD	92
<i>Making a DVD</i>	93
THE INTERNET	94
ARCHIVING YOUR WORK	96
GLOSSARY	99

Television Production Manual

The Camera

We're well on our way to the world of fully automatic "point and shoot" television cameras. Smart cameras are great most of the time and they certainly cut down on the common mistakes most people (even pros) make from time to time. When automatic operation doesn't work, though, the results can be pretty bad. Knowing what the conditions were that fooled your "smart" camera will help you to know when to turn these features off and do it the old-fashioned way. But before you do, you need to know what cameras do and how they work.

The television camera changes light into an electronic signal that can be stored (using video tape, optical disks, or computer memory, transmitted, and displayed on a television receiver or monitor. Television cameras are probably easier to operate well than film or still cameras because you can watch and control the camera output as you record. There are few electronic controls, and the manual controls on the lens will be familiar to anyone who has used a good still or motion picture camera. Since video cameras can, as a rule, produce sharper, clearer pictures than the recording media they were designed to work with, the quality of your camera is seldom an excuse for fuzzy pictures. Understanding how to use the camera correctly will help you avoid poor results.

Lens Controls

The modern television lens has three controls: iris, focus, and zoom. On a fully automatic camera you may not have to adjust the focus or iris except under unusual conditions, but you should know what's going on so you can use manual settings with confidence.



Iris

The ring closest to the camera body controls the amount of light passing through the lens to the light-sensitive surface of the pickup tube or chip. It is called the iris, aperture, or f-stop control and is marked off in f-numbers. The lowest f-stop lets in the most light, and the highest f-stop lets in the least. Some lenses even have a "C" setting after the highest f-stop which means the lens is completely closed, letting no light through at all.

More light----- Less light
1 1.4 2 2.8 4 5.6 8 11 16 22 32
STANDARD F-NUMBERS

Each standard f-stop lets half as much light through the lens as the f-stop below it.

If the camera gets too little light, the image will look fuzzy and drab, even though it may be in focus. The camera image may lag behind quick changes in the picture and the picture will be grayish, with little contrast.

Too much light will produce too much contrast. Details in both the very bright and the very dark parts of the picture will be lost. Bright spots may grow "halos" or "bloom." So-called "point sources" of light may cause light vertical stripes on CCD cameras.

The correct setting is between these extremes, generally about one f-stop higher than the f-stop at which the bright parts of the picture lose details and grow halos, or "bloom." To find this point, begin with the lens in the closed or highest f-stop position and open it slowly until you start losing details in the brightest parts of the picture. Then reduce the amount of light coming through by going down to the next highest f-stop.

Indoors it's often necessary to add light to get a good picture. Outdoors on bright sunny days it may be necessary to reduce the light reaching the pickup tube even more than the lens will allow. This is done by adding a neutral density filter between the lens and lens hood. A two power (2X) filter has the same effect as using the next highest f-stop, while a four power (4X) filter gives the effect of going up two f-stops.

Zoom

The center ring on most lenses is the zoom control. Most cameras use a rocker switch beside the lens. This allows you to change the focal length of the lens through a range from wide angle (short focal length) to telephoto (long focal length). It's common for inexpensive zoom lenses to have a range of about six to one. That is, the longest focal

Television Production Manual

length is about six times the shortest. Zoom lenses for television cameras with two-thirds inch pickup tubes or chips range from about 12mm to 75mm, with a normal focal length of about 33mm.

A wide-angle setting makes the subject smaller as the angle of view is increased. Distances from the camera are exaggerated, with objects nearer the camera appearing abnormally large. This is especially true of people who are too close to a wide-angle lens. Straight lines near the edges of the picture are often bent with an effect known as barrel distortion.

A telephoto setting makes the subject larger as the angle of view is reduced. Distances from the camera are compressed. More than one feature film director has used this effect to make an action (like running toward the camera) seem to take much longer than it should.

The normal lens settings offer the most natural perspective to the viewer. It's possible to change the focal length of a zoom lens during a shot by "zooming" in or out. Inexperienced camera operators often over-use this capability. The main value of the lens is in controlling the field of view of the camera when it's inconvenient or impossible to change the distance from the subject to the camera.

Focus

The focus control is the ring farthest from the camera body, on the front of the lens. Distance settings are marked in meters and in feet. While a non-zoom (fixed focal length) lens is focused simply by turning the ring until the image is sharp, the zoom lens must be zoomed in to the smallest angle of view and the largest image size to adjust focus. The lens should then be zoomed out to the widest angle of view and the smallest image size to make sure the image stays in focus through the entire zoom range. If the image stays sharp, the lens will remain focused at any focal length as long as the distance from the subject does not change.

Depth of field is the range of distances in front of the lens in which objects appear to be in acceptable focus. It's longer for short (wide-angle) lenses than for long (telephoto) lenses, and it increases as you use higher f-stops. It is often wise to use a higher f-stop when lighting conditions permit, if you expect the distance between the camera and the subject to change often while you're taping, since you'll have less trouble keeping the subject sharply focused with greater depth of field.

While all cameras with zoom lenses must control iris, focal length, and focus, the functions of the three rings described here may be automated or provided by remote control.

Most lenses also have a "macro" setting on the zoom ring. This changes the characteristics of the lens to let you focus on objects right up to the front of the lens.

Electronic Controls

Some or all of the following controls may be automatic or preset and thus not adjustable by the user.

Pedestal

Also called the "set-up" control, sets the level of the darkest parts of the picture. On portable cameras it's generally automatic or totally absent.

Gain

Also called "level," this control sets the level of the brightest parts of the picture. It can be used to reduce the level when too much light is striking the pickup tube, but it will not make the picture brighter without making it grainy or snowy if the pickup tube or chip isn't getting enough light. Automatic gain controls can be extremely sensitive to even small bright parts of the picture, driving medium and darker parts into black. They may also bring dark parts up into the medium range if there's not enough light for a good picture.

White Balance

If you use outdoor film with normal indoor lighting (no flash) everything comes out orange. The color temperature of sunlight is very different from an incandescent light bulb. Most consumer cameras now sense the overall color temperature and adjust color electronically. In older or professional cameras it may be necessary with each change in location or lighting to "tell" the camera how to interpret color. This is done by showing the camera a white card, which represents the total absence of color. Controls on the camera are then used to minimize the color output of the camera.

Viewfinder

There are often controls to adjust a camera viewfinder. To state the obvious, these controls have absolutely nothing to do with the actual output of the camera. It's helpful to adjust the viewfinder under controlled conditions so it shows a faithful representation of actual camera output. Otherwise, if you want viewfinders to tell you the truth, they should never be adjusted just to make a "pretty" picture.

Television Lighting

Television is a means of changing patterns of light into electrical signals for storage or transmission and then recreating those patterns on a screen. In order to do this well, the television camera must be presented with properly illuminated scenes. The three important considerations are overall level, contrast range, and color temperature.

Level

Lighting levels for television are generally set by adjusting the incident light, or the light striking the subject. The unit of measure for incident light is the foot candle, which is the amount of light produced by a standard candle at a distance of one foot. Lighting measurements are made using an incident light meter, which has a white plastic cover over the sensing element and a logarithmic scale calibrated in foot candles. To measure the useful incident light for television, the meter is held near the subject and pointed toward the camera.

The minimum acceptable level for color television depends on the ability of the lens to transmit light to the camera, the sensitivity of the pickup tube or chip, and the amount of depth of field you need. For high-quality pictures you need something between fifty and two hundred foot candles. Most cameras can be operated in light ranging from the minimum up to ten thousand foot candles, or fairly bright sunlight. Where lighting conditions fall outside this range, steps must be taken to bring the lighting level into line with the capabilities of the camera. With too little light, additional lighting must be added. With too much, special neutral density filters must be used on the camera.

Absolute rock bottom

You'll see cameras advertised as 2 LUX or 4 LUX cameras. 2 LUX is equal to .19 foot candles. 4 LUX is about .37 foot candles. I was suspicious, so a number of years ago I set up an ordinary candle one foot away from a white square on a black background. I tested two cameras. The first was a popular CCD camera requiring four LUX for minimum illumination. The second was a broadcast camera using Saticon pickup tubes. At a nominal one foot candle the CCD camera produced 40 IRE units of video, but the amount of noise in

the picture was very objectionable. At four foot candles the CCD camera produced 100 IRE units with an acceptable noise level. The broadcast camera produced 20 IRE units at one foot candle with the "boost" set at 18 dB. At four foot candles, it produced 46 dB at 0 boost and 95 dB at 9dB boost. At four foot candles the broadcast picture was obviously superior to the picture from the consumer camera.

The difference at one foot candle is essentially the willingness to tolerate more noise in the CCD camera, giving it more apparent sensitivity under extremely low light situations. To mask some of the noise at low light levels, consumer cameras often use a setup, or black level, of zero IRE, rather than the 7.5 IRE broadcast standard. Some cameras that automatically boost the signal in low light situations can also be run in manual mode where you can control how much boost you want to use.

Lighting levels of five to fifteen foot candles are common in homes, while office settings tend to range from fifty to sixty foot candles. Keeping the reservations in the preceding paragraph in mind, consumer camcorders should have plenty of light for acceptable pictures in either setting.

Contrast

Contrast refers to the difference in brightness from the darkest parts of a scene to the brightest.

Useful contrast for NTSC television is determined by the amplitude of the video signal. The NTSC standard calls for a "peak to peak" amplitude of one volt at 75 ohms impedance. Only seven tenths of a volt is used for the luminance, or black and white part of the signal.

Common digital video signals are 24 bit color, with eight bits each for red, green, and blue. This scheme allows for 256 individual shades from dark to light for each color. Since 24 bit color allows for over sixteen million colors, the limited number of shades available for each color aren't usually a problem, although the luminance steps may be visible in monochromatic scenes.

If there's too little contrast many receivers will produce a flat, grayish picture. If there's too much contrast, details in the brightest and darkest parts of the picture will be lost and the picture will look too harsh.

Since contrast is actually light reflected from the subject, it's measured using a reflectance light meter. The meter is held near a variety of very light and very dark parts of the subject and pointed toward each part of the subject to be measured. The ideal contrast range for NTSC television is about twenty to

one. This corresponds to a difference of about four and one half f-numbers between the darkest and brightest parts of the picture on a reflectance light meter. In practice, actual contrast ranges are rarely measured using a meter. A subjective analysis based on camera output is generally sufficient.

Color Temperature

The third consideration is color temperature. Every source of light has a characteristic color. This color is related to its "temperature." Lower color temperatures tend to be red or orange while higher temperatures tend to be green or blue. Color temperatures are measured in degrees Kelvin. Some examples:

Color Temperature

<u>Temperature</u>	<u>Source</u>	<u>Color</u>
1950	Candlelight	Orange
2870	Normal Incandescent	Orange
3200	Most Photo or TV Lights	Orange
3400	Some Photo Lamps	Orange
3500-4000	Fluorescent Lamps	Green
5500	Midday Sunlight	Blue

The eye "remembers" how things are supposed to look and interprets color accordingly, regardless of the color temperature of lighting sources. A white sheet of paper seems white whether viewed under an incandescent lamp or sunlight. The eye can even adjust for "correct color" when two light sources of different colors are present in the same scene. Sunlight streaming into a room which is also lit by incandescent lamps doesn't make objects it strikes appear bluish.

Television cameras aren't so versatile. They must be set up to render color in a way that's pleasing to the eye. They can do this only if all of the important lighting sources within a scene have the same color temperature. A combination of filters and electronic adjustments is used to adapt color cameras to each new lighting situation. Most cameras can adjust automatically to typical color temperatures. They cannot resolve conflicts when major picture elements are lit at different color temperatures.

Lighting Instruments

There are four basic kinds of lights used in television. They are the spot, the broad, the flood, and the soft light.



The spot has a narrow beam that casts well-defined shadows.



The broad is a rectangular light that has a somewhat wider beam and casts softer shadows.



The flood light throws a broad, even illumination in a circular pattern with diffuse shadows.

The soft light (also called a "bathtub") is a array of lights reflected by the white interior of a large box. Used for general background illumination, the bathtub creates shadows that are barely noticeable.

The intensity and beam spread of spots and some other lights may be adjusted by moving the lamp forward or back in the lamp housing. When the beam is narrow and intense the lamp is "spotted down." When the beam is wide and more diffuse the lamp is "flooded out." Not all lamps have this adjustment.



Most lamps can be fitted with "barn doors," which are black metal flaps fastened to the front of the lamp housing. These flaps are used to keep light from falling where it's not wanted. Use of barn doors is most important on backlights, which can cause objectionable lens flare if their light is allowed to strike the camera lens directly.

Scrims are special disks of screen wire which can be used to soften lights and reduce their intensity slightly. Not only can two or more scrims be used in the same lamp to increase the effect, but half scrims or variable density scrims can be used for selective softening of lights. Scrims can also be used in lamps which don't already have protective covers or lenses to contain debris in the event the bulb explodes. Explosions, while rare, are not unknown.

Tungsten-Halogen bulbs are generally used for television lamps. These bulbs retain their brightness and correct color temperature throughout their lives. Unlike household bulbs, however, they can be damaged if touched with fingers (depositing oil on the glass) and are more susceptible to damage by shock. Barring accidents, halogen lamps last from 100 to 300 hours.

Housings may generally be fitted with several different bulbs of different wattages. Acceptable bulb substitutions are often listed on the housing. Bulbs are identified by a three-letter code. Only those bulbs listed should be used in a housing.

Lamps and housing become extremely hot when they're in use. Hot lamps should be handled only with protective gloves to prevent burns.

Power Consumption

Television lights are much more powerful than normal incandescent lights. They range from 25 watts for DC camera lights up to as high as 5000 watts. Lights used for electronic news gathering (ENG) or electronic field production (EFP) normally range from 500 to 1000 watts each. This presents problems whenever they're used in locations that weren't intended for television recordings.

The normal utility electrical circuit has a maximum capacity of 15 or 20 amps at approximately 120 volts. One 500 watt lamp uses about 4.55 amps. A 650 watt lamp uses 5.10 amps, and a 1000 watt lamp uses 9.09 amps. To be safe, no circuit should be loaded to more than two thirds of its capacity to prevent overloads from power surges and to allow for possible weaknesses in the circuit. In other words, a maximum of two 500 or 650 watt television lights should be used on a 15 amp circuit.

The above implies that you know which outlets are connected to each circuit, what the rated amperage for each circuit is, and what else is plugged into each circuit.

The formula for finding the amperage for a specific power consumption is:

$$\text{Amperage} = \text{Wattage} / \text{Voltage}$$

For example, a 500 watt lamp at on a 110 volt circuit will consume about 4.5 amps. To be safe, divide the total wattage by 100. The 500 watt lamp using 100 volts uses five amps. This will provide a margin of safety and makes the arithmetic easier.

Any extension cords used with lights should be heavy enough to carry the load. For short distances, number 14 AWG with rubber insulation will carry 15 amps safely. For long runs, it is advisable to use number 12 AWG, which is the same size wire used in household wiring. In addition, grounding wire and circuits should be used where possible.

The formula above has a second use in calculating battery life. If you have a camera light it's most likely a 25 watt quartz light. At twelve volts, a typical one amp hour battery could operate the light for half an hour.

Lighting Techniques

In lighting there are two goals: get enough light; use the light you have to shape and define objects in the scene. Lighting is often tried out "on paper" by using a lighting diagram before it's actually set. Many potential problems can be spotted in the process of constructing a lighting diagram. The most common of these is to light for a theoretical "stage front" instead of lighting for specific camera positions. It's also useful in anticipating problems with shadows falling where they're not wanted. Every light casts a shadow. The lighting diagram will make it easier to see where those shadows might fall.

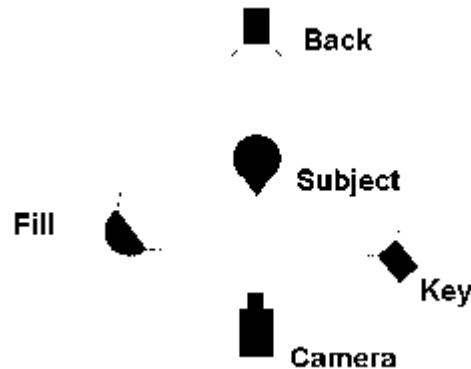

One man, One camera

The simplest type of lighting involves one camera shooting one subject. The subject is placed in the setting far enough away from any walls or backdrops to avoid casting shadows on the background near the subject. The camera is set up placing the subject in front of the backdrop.

Key Light

The first light set is usually the key light. It's positioned thirty to forty-five degrees to the side of the camera and should strike the subject at an angle of about forty-five degrees from vertical. This lighting angle is best for people with normal features. People with short noses or weak chins should be lit from a steeper angle to increase the length of the shadows cast under the nose or chin. Those with long noses should be lit with less angle to produce shorter shadows. Moving the light closer to the camera will reduce the amount of modeling in the face and make the subject appear heavier than he is. Conversely, moving the light farther from the camera will throw more of the face in shadow, making it appear narrower. The key light is focused on

the subject by putting the bulb in the "full spot" position and centering the beam on the subject. The light is then flooded out until a reasonable overall level is reached. "Reasonable" means you can generate sixty to seventy IRE units of video on faces with minimal video noise in the picture and enough depth of field for your purposes.

Back Light

The back light is placed directly behind the subject, in line with the camera. It, too, is set at a forty-five degree angle from vertical. The back light is spotted down and aimed at the subject's neck. It is then flooded until it has about the same intensity as the key light. The back light should be adjusted to produce a crisp but subtle border around the subject. People with blonde (or missing) hair require less intensity. People with very dark hair require more. When the back light is still too bright in the full flood position, a scrim can be fitted in front of the housing to soften and reduce the light.

Fill Light

Fill light is added on the side of the camera opposite the key light. Fill light should be about half the intensity of the key and back lights. It should also be softer, producing no harsh shadows. Often a broad, scoop, or soft light is used instead of a spotlight to provide fill. Fill lights are also frequently scrimmed to soften them and reduce their intensity.

Background

Finally, background light is added to bring the background up to a level in the middle of the overall gray scale of the subject. Background lighting should be even and unobtrusive. The background shouldn't be made the center of attention with harsh or uneven lighting.

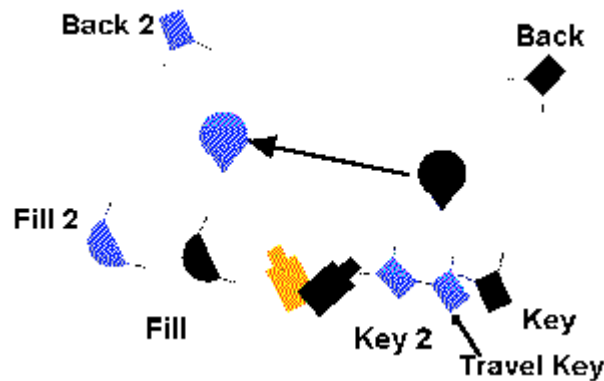

Movement

But what if the subject moves? Depending on the movement, there are two ways of handling this problem. Suppose the subject moves from one important area to another along a pre-determined path. It is neither necessary nor desirable to provide full key, back, and fill along the entire path. It is necessary only to provide about the same overall illumination along the path of travel. This may be accomplished either by making sure the lighted areas overlap sufficiently that no drop in level will be detected by the viewer, or, where distances are greater, by adding sufficient fill along the path to keep the level reasonably constant. In general, back light for a movement from one lit area to another isn't necessary.

When movement of the subject is likely to be random or to cover too large an area of the set, it is possible to provide a diffuse fill lighting to the entire area. This is commonly called "base light" and is designed to keep all shadows within acceptable contrast range. Key and back lights are then added for specific areas and camera positions as necessary. While this kind of lighting might be helpful in certain situations, it generally results in a flat and dull overall appearance. Since every light used creates its own shadows, this technique can also result in multiple shadows detracting from the modeling effects rendered by a more orthodox application of key, back, and fill techniques.

Cross Lighting

When a quick and simple lighting plan is needed, cross-lighting is usually the best approach. Adjustable spotlights are placed in the corners of a room, flanking the intended camera position. Because they must "throw" their light some distance, they should be adjusted for a narrow beam (spotted down) and aimed in a crossing pattern at the opposite corners. Unfocused light loses its power with the square of the distance from the light. Normally this would make foreground subjects too bright and background subjects too dark. By

spotting the lights and aiming them at the corners, the loss of light with distance is minimized and the narrow spread of the beam reduces the amount of light striking foreground subjects.

Lighting for Dance

In some cases, even the standard television lighting is too flat for the desired effect. The most prominent example of this situation is in dance. While dance suggests an even illumination of the entire set, it is usually desirable to create shadows that show off the dancers' form. This is done by lighting from greater angles than normal. There is often little or no light from the direction of the camera. Instead, lights are placed at from about seventy to ninety degrees from the camera position. Back light, too, is steeper than normal.

Of course, the mood and artistic objectives of the dance have to be considered. It's possible that standard television lighting would be appropriate for some dances, especially those involving elaborate costumes or an emphasis on story or drama. More radical lighting might be suggested by dance emphasizing the form and movement of the human body. Steeper lighting does create larger areas of shadow, and widening the difference in intensity between key and fill lighting, even eliminating fill lighting entirely, does heighten the sense of energy and tension important to some ballet and modern dance.

High Contrast

The technique of eliminating fill lighting, leaving only key and back light, is called "high contrast" lighting. While it may be appropriate for some forms of dance, its use in other contexts should be sparing. Not only can it easily be overdone, but it also tends to aggravate some technical shortcomings in low-cost cameras and recorders. Any tendency for the picture to "lag" will be made unbearably obvious and areas of the picture left too dark will show video noise generated by cameras and recorders with limited signal-to-noise and noise reduction characteristics.

Limbo

Limbo lighting, like high contrast lighting, poses technical problems for less sophisticated equipment. In limbo lighting normal key, back, and fill lighting or high contrast lighting is used, but great care is taken to eliminate any light from the background or floor behind the subject. The intended effect is to leave the subject without any visual context. The more likely effect in analog recordings is a context of video noise, especially if recording or editing for later distribution is intended.

Back lighting

Back lighting is generally used in the attempt to conceal the identity of people on camera or to provide an "interesting" background for program titles and credits. Key and fill lights are eliminated, leaving only back and background lights. Because of the large amount of stray light bounced off of floors and walls, back lighting doesn't completely eliminate "fill" light on the subject and may not therefore provide sufficient anonymity for the subject.

Application

Standard television lighting is basically key, back, and fill. As you look around the real world, you would be hard pressed to find a single example of this rather artificial scheme. So how does this technique apply to you? I remember still photographers on a trip to Panama years ago saying "I hate this light." or "The light isn't right yet." What they hated was the high angle of the tropical sun at midday. They wouldn't like the light until the sun fell to about a forty-five degree angle, or the proper angle for a key light. Outdoors the sun is the key light. North of the tropics, the sun is at a good angle in mid morning and mid afternoon. I've often taken one look at a building and decided whether to record it in the morning or afternoon. I've also selected the camera position to put the sun in the right place in relation to the camera.

Outdoors, the content of the sky is very important. Obviously, dark clouds and rain don't do much for a positive image. But even a light cloud cover or haze can make a profound difference in your pictures. On a clear day, a sunlit structure will be brighter than the sky. You can throw a couple of nice clouds into the background for effect, but basically the blue background is darker than the sunlit subject. Light haze and clouds will almost always be brighter than the subject. They could make the White House look like a medieval dungeon.

Striking pictures, whether still, film, or video can be made using the sun as a back light, or by playing with the angle between the camera, subject, and sun. If you remember where the key light is in conventional lighting, you can use it as a guide to shooting outdoors, both by following and by breaking the rules.

Office lighting generally runs from fifty to one hundred foot candles. Obviously plenty for good pictures. Unfortunately, all of those fluorescent lights point straight down. Eye sockets are turned into black holes. Lights in the background are brighter than the subject. I've found that the cross lighting technique we mentioned can provide key and fill lighting in the

typical office environment. It throws enough light on the back walls or other distant objects, and provides the modeling that would otherwise be missing. The fact that the background light is at 4500 degrees Kelvin while the key and fill lights are at 3200 degrees Kelvin doesn't seem to cause a problem, as long as the camera is white balanced for 3200 degrees Kelvin.

Lighting and Image Resolution

In creating video images we want to produce pictures that appear sharp and clear without being harsh. Spotlights have traditionally been used as key lights to provide clear, crisp images with video formats that lacked resolution. Although industrial and broadcast cameras have generally had resolution superior to the broadcast signal, the same cannot be said for videotape. While the calculated resolution of broadcast television is around 330 horizontal lines, VHS tape has a resolution of about 230 to 240 lines. Betamax and $\frac{3}{4}$ inch U-Matic tapes were 240 to 260 lines. With the advent of S-Video both consumers and professionals could record at a better-than-broadcast 480 lines of resolution. Now DV (digital video) offers a calculated 530 lines of horizontal resolution and high definition television can deliver more than twice that.

As resolution improves, traditional television lighting tends to be harsh and unflattering. To adjust to this change in technology, some broadcast news sets are now lit by banks of soft lights. Others still use spotlights, which tend to exaggerate facial creases and wrinkles. This is especially unfortunate for people with thin faces. With the increased sensitivity and resolution, we can sometimes employ techniques more common to still photography. Bouncing a spotlight off of a silvered umbrella, for example, will create a much softer light that is more flattering to people. We will have to work with additional changes to both lighting and makeup as we move to high definition video.

That "Homey Look"

Homes are comfortable, friendly places. They are warm and nurturing. Broadcast television spends a lot of time and energy trying to mimic the "homey" look, whether in daytime dramas or situation comedies or talk shows. As you look around your own living room, here are some of the concerns the network producer might have in reproducing "the look."

The most important means of avoiding the "studio look" is to simulate more conventional room lighting. That is not to say that normal room lighting should be imitated. Rather, the effects of room lighting should be examined and recreated for the camera. These effects fall into two broad categories. The basic area illuminated by room light is normally at the level of table lamps and below. Light normally falls off toward the ceiling. By aiming lights and using barn doors to reduce the amount of light near the top of the set, this effect can be imitated. Even though lighting angles are those of conventional television, the viewer will associate lighting with those lamps found in his normal environment, provided reasonable diffuse fill light is

combined with key and back light that doesn't create hard and distracting shadows.

Next, key light positions may be modified and adapted to represent visible or implied lighting sources. Again, it's neither possible nor desirable to use the lighting angles and positions that might be found in a home. Instead, key lights might be placed to strike the subject from the same general angle to the camera as the visible or implied source. There might be key light from more than one general direction, casting shadows representing several sources. Lighting angles from the vertical, however, shouldn't be modified, since lowering key lights will cause unacceptable shadows on backgrounds (or subjects) and extremely steep angles will create dark shadows in eye sockets, as well as long nose and chin shadows. Where the implied lighting source gives off little or no light itself, the most distracting shadow of all is that of the implied source cast on the background by the key light. When this happens it's painfully obvious that the light in the picture is not a practical source of illumination.

As a rule, it's better not to use visible implied light sources, since it's difficult to protect the camera from them without destroying the intended effect. Even an extremely low-wattage bulb in a table lamp will exceed the contrast range a camera can accommodate, since it's a source for direct, rather than reflected, light. Such apparently innocent light sources as candles and lanterns give off more light than many cameras can handle. The resulting effect is anything but "natural." If some means of screening the camera from direct light from an on-camera source can be found and if the appearance of the source is reasonable natural, the effect of such implied lighting can be very effective.

It's possible to suggest a light source through the use of distinctive shadows. Special focused spot lights can be used to project patterns onto the set. The pattern of a window might be used to suggest sunlight streaming into a room, for example. With low light CCD cameras, even normal slide projectors can be used to throw suggestive shadows.

Regardless of the light sources you use, the concepts of key, back, and fill lighting are important to making your subjects as attractive and dynamic as possible. Often in the real world you have to place the camera and subject in such a way that existing light does this job for you. In some circumstances (such as office-style fluorescent lighting) there may be no alternative to bringing in additional lights for modeling purposes. It's not important whether you use existing light or normal tungsten lights or quartz-halogen television lights. The relationship between the subject and the key light and

Television Production Manual

the relationship between key, back, and fill light sources is important to creating effective images on tape.

Composition and Camera Movement

Composition

Composition exists in a context. That context is the frame, which is itself an element of picture composition. In 1894 Thomas Edison introduced the Kinetoscope motion picture format, with an aspect ratio (ratio of picture width to height) of four units wide to three units high, or 1.33 to 1. For the next fifty years most film used the 1.33 aspect ratio. Sixteen millimeter, eight and “super eight” millimeter film formats and NTSC, PAL, and SECAM television standards all share the 1.33 ratio.



4 x 3 or 1.33 Aspect Ratio

From an optical standpoint, the most efficient rectangular format would be square, since it would use as much of the lens area as possible. So why don't we have square pictures?

Artists and mathematicians from the ancient Greeks and Egyptians have focused on the “golden rectangle” as the perfect shape. The aspect ratio of the golden rectangle is 1.618. One might presume (although I've found no evidence so far) that the 1.33 aspect ratio is a compromise between the most efficient ratio and the most esthetically pleasing.

Television Production Manual

Over the years a number of standard sizes with different aspect ratios became popular. The 8x10 photograph (1.25), the 4x6 photograph (1.5), and the 35mm slide (1.5) are a few examples. Film evolved, too. Cinerama (2.5 - 3.0), Cinemascope (2.55), and Panavision (1.78 – 2.4) are a few standards among many. High definition television has an aspect ratio of 16 by 9, or 1.78. The shape of the frame is the first consideration in composition.



16 x 9 or 1.78 Aspect Ratio

Ideally, every shot in a television program should be composed as carefully as a still photograph. While this is not often possible, some general rules of composition should be kept in mind.

Television Production Manual

The face of the typical television screen has been surrounded by a frame called a shadow mask, which hides about five per cent of the picture.. The composition of the same image will be different with and without the shadow mask. The presence of the shadow mask has always caused a problem for films transferred to video because they were generally composed to be shown “edge to edge.” Now the same problem occurs when images are composed using a digital (LCD) monitor without taking the shadow mask into consideration.



The red border around the frame represents the shadow mask. It is unlikely the viewer will see anything in this area. The gold and green areas combined are referred to as the safe action area. Anything that takes place here is likely to be visible to the viewer. The green area is known as the safe title area. It is virtually certain that any text in the green area will be visible to the viewer.

Television Production Manual

Notice the difference in "head room" in the pictures below this text. If you are using a camera with a monitor that shows the entire picture, be sure to allow for the shadow mask when you are composing your shots. Some viewfinders have "safe area" masks or lines to help you.



Television Production Manual

Unless your subject is perfectly symmetrical, the screen should never be divided exactly in half by strong horizontal or vertical lines. Instead, it should be divided approximately into thirds. For example, the horizon (if you're shooting a corn field) should be either a third of the way from the bottom of the screen or a third of the way from the top. With the exception of titles, composition should not be perfectly symmetrical, but should rather balance positive and negative (filled and empty) space.

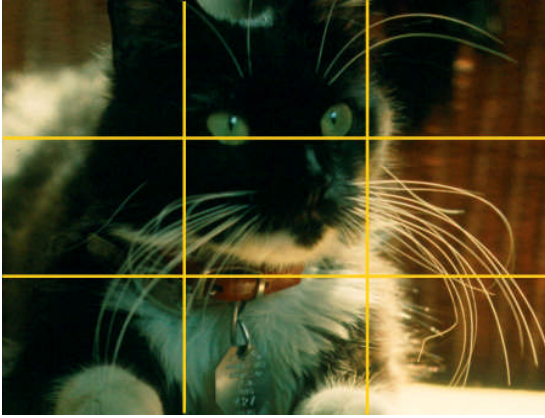

Intelligent use of composition can be used to draw the viewer's eye to important parts of the picture.

Too High



Too Low

Television Production Manual

When framing people, there are several additional concerns. By placing someone too high or too low in the frame, the individual can be made to seem taller or shorter than he actually is. The tendency is to place people too low.



When the screen is filled with a face, the critical part of the face includes the eyes, mouth, and chin. The picture should be framed to include those, allowing hair or ears to fall outside the frame.

When shooting a profile (side view) of a person, it's important to allow empty space in the direction the subject is looking. This extra space is called "nose room."



Insufficient Nose Room



Good Nose Room

Nose room applies not only to people, but to anyone or anything pointing or moving. There should be relatively more empty space in the direction of the pointing or movement.

The kind of framing a writer or director wants is usually described in terms of wide, medium, or close-up.

Television Production Manual



A wide shot includes the entire subject and important objects in the immediate surroundings. It's used to show where he is in his environment. If it's used at the beginning of a scene it's often called an "establishing" shot.



A medium shot shows most of the subject, including all parts of the subject that are important to understanding what the subject is doing. A medium shot of a person sitting still might show his body from the waist up, letting hands and the lower half of his body fall outside the frame.

A medium shot of a person dancing or performing Tai Chi, on the other hand, would have to include his arms and hands, since these are generally important to understanding what he's doing.



A close-up is used to isolate the most important part of the subject. For a speaker, this is generally the head. For an entire football team, a close-up might be a shot of the quarterback only.

An extreme close-up focuses on one important detail of the subject, perhaps the mouth alone, or just the eyes, if the

subject is a person. The object is to focus on important detail either to increase the drama or impact on a situation or to allow the viewer to see necessary picture information more clearly.

In shooting a group of people, we have a few special terms. A "one shot" is a medium shot of a single person. A "two shot," would still be a medium shot, but the "subject" is made up of two people and the shot is framed tightly around those two. We also use terms such as "head shot," "head and shoulders shot," and "waist-up shot."

Camera Movement

In the age of hand-held camcorders it must seem odd that there's an elaborate vocabulary describing how a camera can be moved. If you can do it, the industry has a technical term for it.



Pan



Tilt

The two camera movements you use routinely are the "pan" and "tilt." A pan is a turning of the camera to the left or right. A tilt involves tilting the camera up or down.

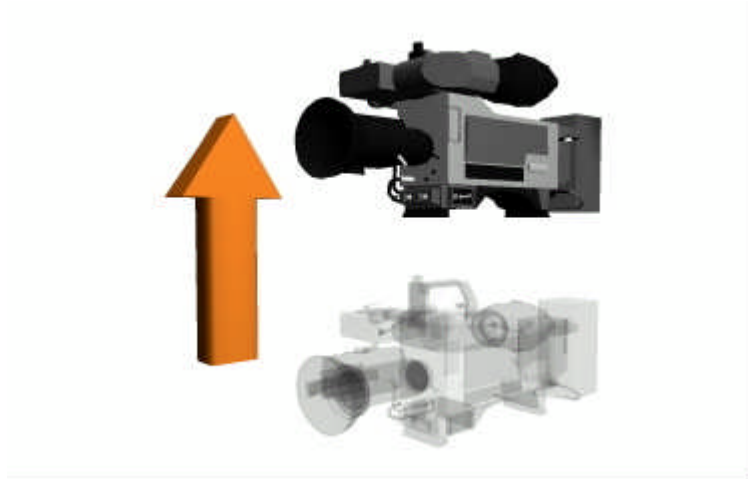

Pedestal Up

The stand for a heavy studio television or film camera is called a "pedestal." That's why the term for raising the camera is "pedestal up," and the term for lowering the camera is "pedestal down." These terms have nothing to do with adjustments to the "pedestal," or setup of the black level of the picture, which is an electronic adjustment, not a camera movement.

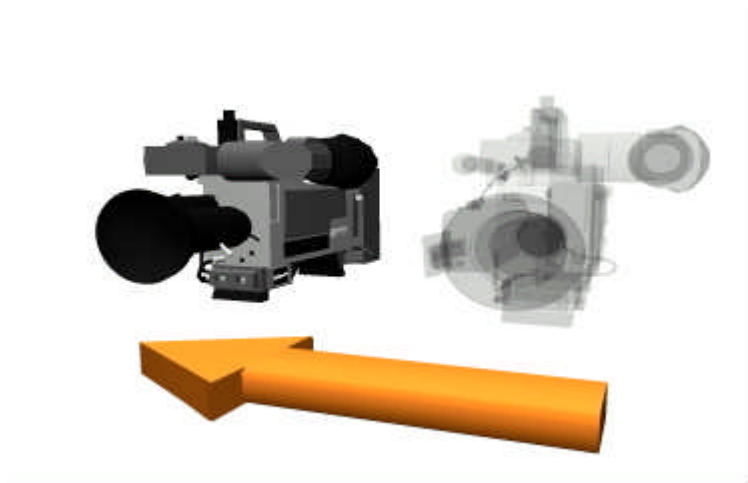

Truck Right

In moving a camera from side to side you "truck right" or "truck left." To move the camera closer to the subject, you "dolly in." To move it farther away you "dolly out." Of course, whenever the camera-to-subject distance changes, the focus must be adjusted.



Dolly In

Purists will point out that dolly shots (in or out) are fundamentally different in effect from zooming in or out. They're right. But professionals will go to extreme lengths to get a smooth dolly shot, to the point of laying special tracks to roll the dolly on. People with more modest means have mounted cameras on bicycles, shopping carts and, of course, cars to get their dolly shots.

Finally, in situations where important parts of a scene are not the same distance from the camera, it's possible to change the emphasis of a shot from one part of the scene to another by changing focus alone. The instruction to do this is "rack" focus "in" or "out" for a particular object in a scene. "Rack focus into the cup on the table," would be an example. Such instructions are rarely used and are generally given for artistic effect.

Television Production Manual

Basic Audio

In most video programs it's the audio portion that organizes and makes the visual intelligible. For some types of programs the absence of sound would make the production completely useless even with the best visuals. Ideally, though, if attention is given to high values in both audio and video, each serves to compliment the other. The result is a program that communicates powerfully and effectively.

In some ways, the general lack of good audio values in video might be attributed to the design of the video recorder. With most small, portable video units, a microphone is built into the camera, and sound synchronized to the action in the scene is automatically recorded along with the video. It's so easy that people tend to forget about the limitations in this setup and alternative techniques that are available.

Connections for composite video are pretty straightforward. If it says "video" then it's one volt peak to peak with an impedance of 75 ohms. Period. Audio connections are not so simple. To make connections from one piece of equipment to another with confidence, you need to know some basic audio terminology, and a little theory.

Technical Terminology



Unbalanced Audio Cable

Unbalanced lines are cables with only a single conductor and a grounded shield. They're used for "mic in" jacks rated at 600 ohms impedance and "line" or "auxiliary" in jacks rated at 10,000 ohms or higher. Unbalanced lines are subject to interference, especially in runs of twenty feet or longer. Unbalanced lines can usually be identified if they end in "RCA" jacks, mini-plugs or phone jacks.

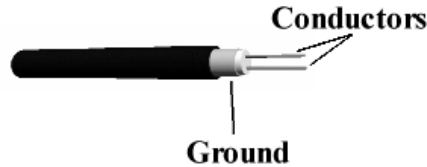

Balanced Audio Cable

Balanced lines are those with two conductors and a grounded shield. The two conductors are used to carry signals which are identical except that one is inverted and is opposite in polarity from the other. Any interference picked up on the two conductors will have the same polarity on both. When the two signals are recombined in a transformer, the interference cancels itself out. This makes balanced lines the best choice for long cable runs. Balanced lines are generally used for 600 ohm "line" or 50-250 ohm microphone inputs. Generally, if the cable ends in a cannon (XL) connector it's balanced.

NOTE: Coupling a balanced line to an unbalanced line directly without using a transformer unbalances the entire length of the balanced line and defeats the purpose of using it.

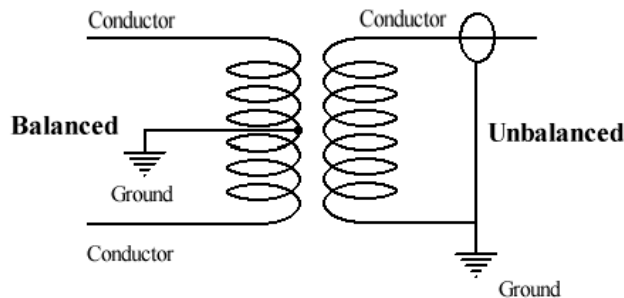

Transformer

Impedance is a technical term that refers to the apparent resistance a circuit presents to an alternating current. This apparent resistance is measured in units called ohms. The maximum signal transmission between devices with the lowest distortion occurs when the input and output impedances are the same. Most audio devices fall into one of three categories; microphones generally have low impedance (50 to 250 ohms), balanced lines are rated at a nominal 600 ohms, and unbalanced lines (used in consumer stereo equipment) have high impedance (10,000 ohms and higher). Don't worry about an exact match. Simply connecting outputs to inputs in the same impedance range is sufficient.

Cables connecting high impedance devices are more susceptible to losses and interference as the length of cable increases. Cables connecting low impedance devices are less likely to have problems. Low impedance balanced cables can be run hundreds of feet with minimal problems.

Level - The sensitivity of audio inputs is another important variable. The standard line level is one volt peak-to-peak (.775 volts RMS) at 600 ohms. Microphone outputs and inputs vary. Specifications are given either in millivolts or in decibels. Using established convention, two typical microphone outputs are 1 millivolt (-60dB) and 100 millivolts (-20dB).

Signal to Noise Ratio is the difference in amplitude between unintelligible noise generated within the device and the maximum signal output of the device, again expressed in decibels. Most video recorders should be capable of an audio signal to noise ratio of forty to fifty dB. (Digital audio devices are capable of more than 100dB.) You may have noticed that the range of output signal levels exceeds the signal to noise ratio of video recorders. If you put a mic level signal into a line level input, the signal is so low that it falls in the range of noise. You won't even hear it.

Equipment

Microphones

Microphones capture sound and transform it into electrical impulses that are sent to the video recorder. Although there are a number of different microphone designs, only two are used with most video equipment. From the user's point of view, the main difference is that condenser microphones need a power source (battery or external) and dynamic microphones don't.

Dynamic microphones are generally less expensive than condenser mics. Both are fine for general use. It's hard to find a quality microphone for less than a hundred dollars. Audio purists will spend hundreds of dollars on a microphone.

Microphones are also classified according to the shape of the area of sensitivity around the microphone.

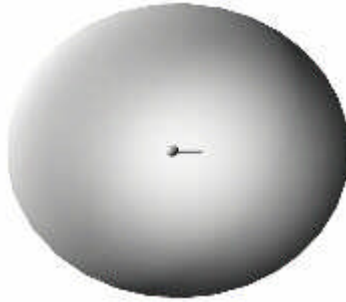

Omnidirectional Pattern

An omnidirectional microphone picks up sound equally well from all directions. It's very flexible in that you can place an omni almost anywhere in most situations and pick up usable sound. Omnis are made for various purposes. One kind of omni is the microphone built into the camera. This microphone allows one person to handle both the audio and video. Another kind is called the lavalier, a small mic that clips to a lapel or other part of the wearer's clothing. It can be hidden and leaves the performer's hands free.



Cardioid Pattern

Directional microphones are designed to be more sensitive in some directions than others. One example of a directional microphone is the cardioid. Think of looking down over a microphone. A cardioid picks up the best sound in an area in front of the microphone. The shape of its coverage is like a heart. It's great for recording events on a stage where you don't want audience noise to be picked up. Bi-directional mics pick up sound on either side, but not in front or back.



Shotgun Pattern

Shotgun mics have a narrow range that can pull in sound from a distance in one direction.



Parabolic Dish Pattern

An omni can be used with a special parabolic dish to pick up sounds from great distances. You've seen them on the sideline at football games.

Boom

A boom is a long pole to which a microphone is attached. Usually there's a special rubber or foam shock absorber between the pole and the microphone so vibrations in the pole can't be picked up by the mic.

Windscreen

A windscreen is a small cover, usually of foam rubber, that fits over the top of the microphone. The wind screen is used outside and reduces (but doesn't eliminate) the sound of the wind. The windscreen doesn't cut down on the sensitivity of the mic very much. There's no need to remove it if you're working where it isn't needed.

Mixer

In some situations you'll find that certain sound sources will be louder than others. Some sources may be farther away from you than others and so they may not be picked up as clearly. Or, some sounds may be emitted in the presence of and overshadowed by other sounds. In these cases, the use of one omnidirectional mic won't let you record all the sounds you want to capture clearly. To resolve this problem you'll need more than one microphone. This is where you use a mixer, a device that takes the inputs of a number of

microphones and combines them into one output for the recorder. The advantage of this technique is that a microphone can be placed in the optimum position to capture the sound of each source. In addition, the mixer enables you to adjust sound levels from each microphone. If, for example, you were recording a man explaining the skill involved in playing a tuba while the tuba was playing in the background, you might use a mixer to make sure that the speaker's words weren't drowned out.

On the front panel of the mixer are gain controls that adjust the sound level for each microphone. By turning some down and others up, you can get the right "mix" of sounds. After the sounds are mixed, the level of the combined sounds can be controlled by a master gain control so that the sound that goes on your videotape can be adjusted.

Transmitter Mics

Where you can't have microphone cables lying around, but you still need to mic specific sound sources, many people are using radio or transmitter mics. Actually, this involves a microphone plugged into a radio transmitter that sends the signal to a receiver, which is attached to the recorder. While it's a good idea, problems with interference, reflections, and obstacles can turn a good idea into a nightmare. The better systems operate in the VHF band, from 150 to 170 MHz.

Receivers for wireless microphones come in two basic types. Non diversity receivers have a single antenna and single receiver for each microphone. There is no protection against reflection or obstacles. Diversity receivers use multiple (2) antennas and may use one or two receivers for each microphone. The received signals are compared hundreds of times each second and the better signal is used. While diversity systems will help with reflections and obstacles, radio frequency interference will still cause problems.

The VU Meter

Audio recording systems have built-in limitations. When sounds are below a certain level, they're masked by noise. When sounds are too loud, the system can't handle the level and distortion results. If you're in charge of audio during a production, you want to make sure that the sound fed into the recorder falls in an acceptable range. In some instances, with some equipment, there is almost nothing you can do. With some mixers and some audio recorders equipped with VU meters, though, you can control the sound levels. A VU meter shows you a visual representation of the strength of the audio signal expressed in volume units. The maximum allowable sustained level is zero. Most VU meters range from -20 VU to +3 or +5 VU. Although

digital recorders have considerably more range, any sound much below -20 VU will be masked by the inherent noise in an analog recording system. It is good practice to keep important audio between -10 VU and 0 VU.

Monitoring the sound using this meter is fairly easy. Set the audio level so that the loudest sound of any duration just hits zero VU. Occasional peaks may go into the red. If you are recording to analog audio tape you can ignore these fluctuations when setting the levels. When recording digital audio you have a signal to noise ratio of up to 100 dB, but you should never exceed 0 dB, since there is no way to capture audio levels that exceed 100% amplitude. Now you're all set and should leave the controls alone unless the sound levels change. For instance, suppose you're using a fixed position microphone and the speaker suddenly moves away from it after you set the levels. If the needle on the meter only moves a little at the lower end of the scale, you'll have to use the gain controls to boost the level of sound back into the acceptable range. If the speaker comes close to the microphone and starts to scream, and the needle on the meter goes consistently into the red, you'll have to reduce the sound level. Voice should be kept mostly between -7 and 0 VU.

Automatic Gain Control

Automatic Gain Control (AGC) is built into most consumer audio equipment to make the taping of sound easier. It boosts the sound signal automatically when the level gets too low and compresses the sound when it gets too loud. This feature allows one person to handle both video and audio without having to worry about monitoring the sound level. In many situations you'll get usable sound with AGC. Unfortunately, certain characteristics of AGC circuits cause problems in some situations.

Those problems are sensitivity to background (ambient) noise and the reaction time of the system. Most AGC circuits won't boost a sound until it reaches a certain threshold level. The circuit makes an arbitrary decision as to what is noise and what is signal. In a noisy environment (such as a room with a window air conditioner) the ambient sound will be boosted to an unacceptable level. AGC may boost the hum from an amplifier, turning it into a dull roar. Some mixers can emit a low level buzz that may also be boosted by AGC.

The other side of the coin is the problem of reaction time. If during a normal recording there's a sudden loud noise, the AGC circuit often will drive the recorded audio down below audible levels for three to four seconds. If you can take control over your audio levels and operate manually, do it.

Production Tips

- 1) Scout the area where you want to tape before the actual recording. Try to visualize the kinds of recording situations that you'll encounter. If you're alone or short-handed, you might have to settle for the built-in microphone on the camera and hope for the best. If you have many sound sources and you can round up someone to handle the audio, use a mixer and multiple microphones where they're required. If you don't want the microphones to show in a scene, mount them on booms or hide them. Lavalier mics provide excellent pickup and can be hidden easily, but they restrict movement. Where movement is important, booms, sound parabolas, or transmitter mics might be appropriate.
- 2) Make sure all plugs and connectors on cables and equipment fit. Make sure the impedances and levels on all connected devices match. Do not assume that all microphones, mixers, and recorders are designed for compatible impedances or levels. Use adapters only where you are sure devices are compatible.
- 3) Try to visualize where the equipment and microphones will be placed and the dimensions of the area that will be used for taping. Use this information to estimate the amount of audio cable you will need. Again, it is better to take too much than too little.
- 4) Once on location, if you are using fixed microphones, set them at their positions. The optimum placement for a mic is six to twelve inches from and below the speaker's mouth. If it's too close you'll get too much bass response and not enough treble. If it's too far away, the level of the voice in relation to the noise in the surroundings may not be high enough. If the mic is directly in the speaker's wind stream, you may get popping and hissing when he pronounces certain consonants.
- 5) Lay out the cables and attach them either to a mixer or video recorder, then use gaffer's tape (or duct tape, if gaffer's tape is not available) to tape the cable to the ground every six to twelve feet. In high-traffic areas either cover the cable with a rubber mat or tape all along the cable so it's impossible to trip over. This will reduce the chances of someone hurting himself or damaging equipment.
- 6) Whenever possible, set sound levels using a VU meter.

Television Production Manual

- 7) Whenever possible, monitor the sound going to the recorder. Listen for high levels of background noise from the location, hum and other interference in the lines, and distortion, as well as a good sound mix. When a problem is discovered, it's generally better to correct it, even if it means delaying taping.
- 8) Watch for idiosyncrasies in the performers that might affect the sound. Tapping fingers or banging fists near table-mounted microphones are annoying. Some people are nervous on camera and rub their hands over hand-held mics or microphone cables, causing a distracting scraping sound. People who tap or scratch their chests while wearing lavalier mics also can be a problem. Lavalier mics may click against buttons or jewelry if they're not carefully placed.
- 9) When using a sound mixer, use tape or a china marker (grease pencil) to label each control to indicate the source. You don't want to turn the wrong control at a critical moment.

If you are recording a live event it is important to be flexible and to be prepared. You probably will not have the only audio system on location. Musical groups are using sound reinforcement and so are most public speakers.

This raises an important question. What audio are you there to record? That answer may change with the nature of the event and your audience.

If, for example, you are recording a public speaker your interest is in getting the cleanest possible recording of the speaker. Any ambient sound is your enemy, particularly the public address system. You want your microphone as close to the speaker as you can get it. If there is only one speaker a lavalier microphone is the best solution. If there will be multiple speakers, a microphone on the podium is the best solution. If there are multiple speakers at multiple locations you will need an audio mixer and an audio operator to keep the active mike up and all of the others down.

If you are recording a musical performance there is more to consider. For acoustic (unamplified) performances you could mic each instrument or group of instruments, mic the audience for applause and reactions, and manage it all with a mixing console. You might not be satisfied with the result if you don't get enough of the reverberation in the venue. You could place a couple of microphones above the front of the stage or performance area. The individual instruments will not be as clean, but your recording will be much closer to the experience in the audience. In well-designed concert halls you

can actually get good results placing your microphones in the middle of the audience seating.

For electronic or amplified performances you will want to place your mics in the audience seating or at the front of the stage.

There are two problems you should consider in advance. First, what if the sound reinforcement is actually louder than the source when the two sounds reach your microphone? And what if the sound reinforcement is so loud that you literally cannot hear the sound in your headphones to judge the audio quality? If you anticipate this sort of problem, your best solution is to isolate your audio console and operator in an adjacent room or at least use a good headset designed to reduce unwanted ambient sound.

EQUALIZATION

Generally speaking, equalization is a tool which is used to correct deficiencies in sound. It involves changing the amplitude of narrow bands within the audio spectrum. It is (and this is important) a form of audio distortion. In other words, if something sounds all right to you, don't waste your time trying to improve it through equalization. To put it another way, any change you make in the audio system is by definition distortion.

The simplest equalizers are the bass, treble, and loudness controls on consumer receivers. Graphic equalizers slice the audio spectrum into a series of narrow bands, while parametric equalizers let you set the target frequency, the width of spectrum, and the amount of boost or attenuation you want. While graphic equalizers have a wide variety of uses, from matching sounds recorded with different microphones or under varying conditions, Parametric equalizers are better at isolating and reducing the impact of undesirable background sounds.

Sound is a more important part of most television programs than the viewers ever realize. Unless you do an adequate job of treating the acoustical and aesthetic problems involved, the entire meaning of your program can be distorted or obscured. As in any other area of television production, experience and common sense prove to be your most valuable tools.

Basic Video

Nothing could be simpler than picking up your camcorder and shooting a little videotape out in the back yard. At least on the surface. It's useful to remember that television itself was only a laboratory curiosity in 1940. In the 1950's you could make black and white television images in a studio, but you couldn't record them on videotape until 1956 when Ampex introduced the first commercial videotape recorder at the modest cost of \$75,000 per machine. In the 1960's color television became common, and in the late 1970's videotape recorders found their way into businesses and schools. Cameras and recorders intended for individual use first hit the scene in the 1980's.

NTSC Video

Actually, there are three distinct analog television formats in use around the world today, with a number of variations. The American system (NTSC) was the first. The color signal was designed to work with the pre-existing black and white standard. The same broadcast bandwidth that was designed for high-quality monochrome signals was made to accommodate the far more demanding color signal. At the same time, color transmissions had to be compatible with existing monochrome receivers. Compromise was the word for the day, and quality suffered as a result. The PAL system was designed for color from the ground up, as was the SECAM system. PAL is used in England, Germany, and most countries having ties those two. The SECAM system is used in France, the Soviet Union, and countries associated with them.

There's no need to get into specific differences between standards. Since virtually all television in North America conforms to the NTSC standard, that's what we'll deal with.

The television picture is generated by a complicated combination of signals. It's useful to look at these signals, collectively called composite video, from two different perspectives. First, we'll look at the mechanics of displaying, or

writing, the television picture in terms of time. Then we'll see how the parts of the video waveform are combined to make a picture appear on the screen.

Writing on the Screen

In non-electronic visual media (photography and film), each complete picture is displayed or seen in its entirety instantly. The television image, like a wire photo, must be "written" onto the screen dot by dot and line by line. This done in the United States according to standards set by the NTSC (National Television Systems Committee). Like film, television consists of a series of pictures. While film pictures are presented at a rate of twenty-four frames per second, television pictures are displayed at a rate of thirty frames per second.

The Television Scan

The picture is actually created by a stream of electrons striking a phosphor screen on the face of a CRT (Cathode Ray Tube). When a phosphor dot is hit by this electron beam, it glows for a fraction of a second. To aim the electron beam, two control systems are used. The vertical circuits move the electron beam from the top of the screen to the bottom, while the horizontal circuits move the beam from left to right. This movement from top to bottom and left to right is called the trace. The return path (bottom to top and right to left) is called the retrace. The electron beam is turned off during the retrace. The NTSC picture consists of 525 horizontal lines displayed every thirtieth of a second. Instead of writing all 525 lines with each vertical trace, however, only every other line is written, odd numbered lines on one vertical trace and even numbered lines on the next. Each half of the picture is called a "field" and consists of 262 1/2 lines (half of 525). In order to write all 525 lines every thirtieth of a second, there must be two completed vertical traces for each picture. Thus, the field rate is sixty fields per second while the frame rate is half that, or thirty frames per second. A special series of signals, called equalizing pulses, is provided to make sure the two fields of video fit together, or interlace, properly.

Both PAL and SECAM signals have 625 horizontal lines, with a frame rate of 25 frames per second. Because of the slower frame rate both are able to display more picture detail than the NTSC system in the same bandwidth.

Composite Video

The portion of the waveform that causes the picture to be displayed on the screen in the right place at the correct rate is called "sync." The waveform that controls the brightness of the screen (by varying the strength of the

electron beam) is called "video." Combined with the luminance signal is the signal that controls the hue and saturation of color in the picture. The three signals combined are called "composite video."

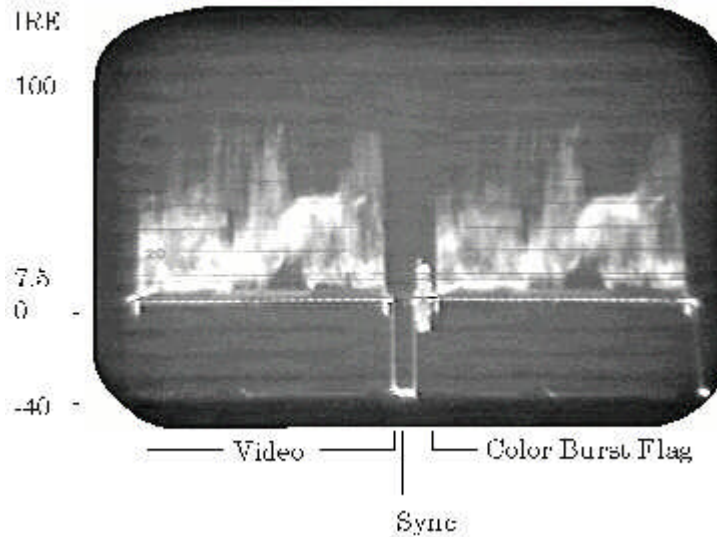

Two Horizontal Fields

Composite video is distributed through television systems through cable at a level of one volt peak to peak with an impedance of 75 ohms. The scale used to measure the amplitude of the video signal is divided into IRE (Institute of Radio Engineers) units. The picture part of the signal (disregarding the chroma portion) should lie in the area above zero up to 100 IRE units. The sync portion of the signal should be a series of pulses going from zero IRE units down to -40 IRE units.

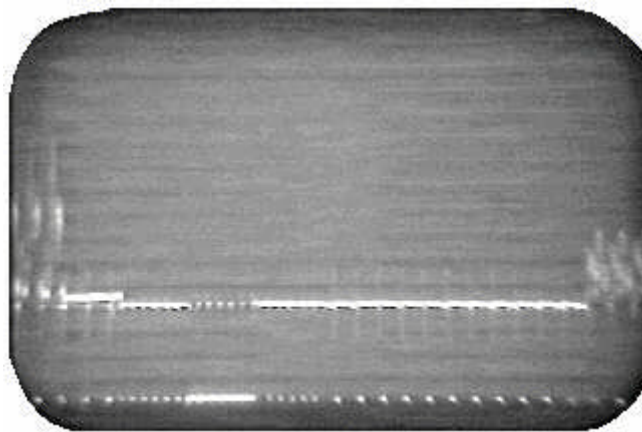

The Vertical Interval, with Equalizing Pulses

Sync consists of horizontal pulses, vertical pulses, and equalizing pulses. The total amplitude of the signal, from the bottom tip of the sync pulses to the brightest part of the picture, is 140 IRE units. At a standard impedance of 75 ohms, the correct amplitude of the composite video signal is one volt, peak to peak, so one IRE unit is equal to 1/140 volt peak to peak. Picture sources are set up with "black" at about 7.5 to 10 IRE and maximum brightness for all but brief transient spikes just below 100 IRE units.

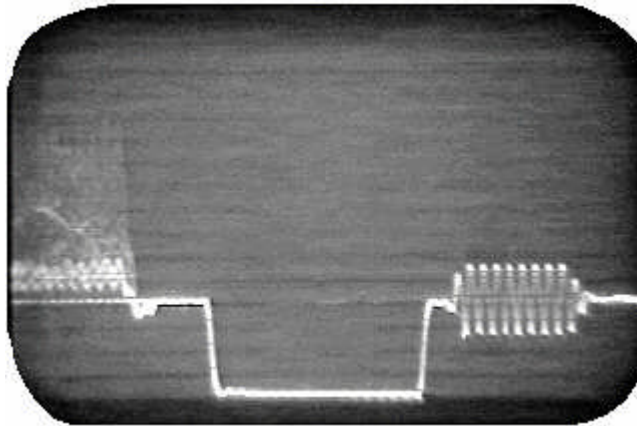

The Horizontal Interval, with Burst Flag

A third signal, neither sync nor video, is always present in color pictures just after each horizontal sync pulse. This signal, called "burst," is a short sample of the color subcarrier frequency and is used as a reference to control the colors displayed on the screen. The burst signal goes from +20 to -20 IRE units. Chroma is not considered in setting black level (pedestal) and level (gain). However, if the video signal including chroma goes below -20IRE, the picture will interfere with the sync signal, which controls how the picture is displayed.

Before the advent of color television, the vertical and horizontal rates for NTSC television were actually 60 Hz and 15,750 Hz, respectively. In color television the rates had to be altered slightly to 59.94 Hz and 15,734 Hz, respectively, to prevent interference with the color subcarrier, which has a frequency of 3.58 MHz.

Component Video

The color NTSC signal is a clever interweaving of different elements. The color portion in broadcast cameras is actually generated by three pickup tubes or chips. The colors are red, green, and blue. There are some pieces of equipment that actually use four independent signals; red, green, blue, and sync. Some combine sync with one of the color signals.

These systems are simply called "RGB systems."

It's also common to combine the three color signals into two, called color difference signals. In fact, the color part of the broadcast television signal is a pair of color difference sidebands.

One of the most common "component" strategies comes from the way the signal is recorded on most VCR's. The color and luminance parts of the signal are recorded separately in a scheme called "color under." Every time the composite video signal is divided into luminance and chroma, and every time it's put back together into a composite signal, there is inevitable loss and distortion. Some systems can keep the luminance and chroma signals separate. The Sony Type V "RF Dub" edit mode is one example. "S Video" is another.

In the end, "component video" is not one standardized system, but rather any scheme that keeps parts of the total video signal separate in order to maintain higher quality. The problem is that these various formats are not directly compatible and the only universal NTSC standard for moving pictures from one machine to another is composite video.

Writing the television signal on videotape

Almost all videotape recorders on the market today are "helical" recorders. All machines record from one to four audio signals on tape just as they would be on an audio tape recorder. Some are recorded by fixed heads in a linear fashion along the length of the tape, while others are recorded by the video heads.

The video signal contains enormous amounts of information. Just as the amount of detail in a photograph is dependent on the fineness of the grain structure of the film, the amount of information you can record on tape is dependent on the oxide structure on the tape. To record enough information for a full broadcast television signal using a fixed video head, the tape would have to be moving at over five hundred inches per second. Instead, two (or more) video heads are mounted on a drum rotating at 1800 rpm. Each head writes a diagonal stripe on the tape representing one field of video. A pair of heads, working together writes two stripes, representing one full frame of video. As the tape moves over the rotating video head drum, a series of diagonal stripes are written onto the tape.

Finding these stripes of video is the job of the last recorded signal, the control track. This signal is nothing more than a 60 Hz pulse recorded on the edge of the tape. Since the physical relationship between the diagonal video tracks

and the individual control track pulses is fixed during recording, it's possible to use these pulses to find the video tracks on playback. The process of finding and reading the video tracks during playback is called "tracking." Failure to find the video tracks causes "snow" or noise in the video, or even complete picture loss.

Compromises

To record the full broadcast spectrum on tape, the original tape format was two inches wide and moved laterally at 15 inches per second. The Ampex videotape recorder had an effective head speed of 1500 inches of tape per second. Making the tape smaller and slowing it down required three key compromises.

The first was a reduction in signal-to-noise ratio. Even tapes recorded on one inch VTR's can be re-recorded up to five or six generations before there's noticeable noise in the picture. On the other hand, VHS tapes have noticeable noise in the first generation and objectionable noise by the third.

The second compromise was in resolution, or frequency response. The luminance bandwidth in broadcast television is 4.2 Megahertz, with a horizontal resolution of 336 lines. The luminance bandwidth of VHS tape is about 3 Megahertz, allowing a resolution of 230 to 240 horizontal lines.

The third compromise involves using the "color under" technique to record a very low resolution version of the color signal at a frequency below the luminance signal, on the assumption that a relatively sharper monochrome signal will mask the fuzzy color signal. It works, to a point. In fact, first generation VHS or 8mm tape looks reasonable.

You can extend the resolution of a recorder if you're willing to accept more noise. Noise becomes objectionable at about three IRE units, or an overall signal to noise ratio of about 35dB. You can fake resolution by using "image enhancement," which is a process that amplifies transitions between light and dark parts of the picture. Too much "enhancement" gives the overall picture a pasty look, especially in areas of fine detail.

While these tricks might make a first generation recording look somewhat better, as you copy a tape from one generation to the next the effects of all of your compromises and tricks are compounded. In the end, you can't beat the laws of physics. In the analog world, there are really only three ways to get better pictures on tape. The first is the traditional solution of moving the head over more tape by making the tape wider or by increasing the linear tape speed. The second is to improve the tape by reducing the size of the

magnetic particles. This is the route taken by moving from metal oxide tapes to metal tapes. The third is to keep the luminance and chroma signals separate in some sort of "Y/C" scheme.

Digital Video

The first digital video format, D1, was introduced in 1986. Unfortunately there were no personal computers with enough storage, memory, or processor speed to use it. Within four years Newtek had a viable add-on for the Amiga computer that could function as a video switcher, graphics generator, and 3D modeler. Still, there was no practical way to capture or store digital video. By the mid 1990's we were using video capture cards to convert the NTSC video signal to digital computer files and using nonlinear editing software. Digital video has no need for synchronizing signals, so only the picture content of the NTSC signal was digitized as a 640 x 480 pixel frame, the same as a VGA computer image, and maintaining the 1.33 aspect ratio.

By the year 2000 the DV (digital video) standard allowed direct digital recording on videotape. Unlike the NTSC standard, the digital video recording consists of 24 bit color images, 720 pixels wide by 480 pixels high, that can be sent directly to disk as a computer file. DV is also referred to as SD, or Standard Definition, as opposed to HD, or High Definition. SD digital video does not have square pixels. To improve resolution over a standard 640x480 pixel VGA display, digital video pixels are nine tenths as wide as they are high, allowing for 720 horizontal pixels by 480 vertical pixels with the same 1.33 aspect ratio.

There is a second version of SD digital video, which has pixels that are 1.2 times as wide as they are high. The same 720 x 480 picture in this format yields an aspect ratio of 1.78, or 16 x 9. It is not advisable to shoot in 16x9 SD unless you are sure that your software and hardware will recognize this format and play it back correctly at each stage of post production, including nonlinear editors, conversion programs for MPEG2, Windows Media Files, Real Player, or Quicktime, DVD authoring software, and playback equipment. Compression schemes that look good with .9 to 1 pixels may not work as well with 1.2 to 1 pixels, especially where fast cameral movement is involved. Before shooting 16x9 SD, test every link in your production chain.

The 24 bit color scheme allows for eight bits each to represent red, green, and blue. In effect, digital video is component video in digital form. Each eight bit color can have 256 distinct steps from darkest to brightest. The total number of possible colors is 256 cubed, or 16,777,216. Any device or system that has "16 million colors" is 24 bit color.

Unlike the original D1 digital standard, the DV standard is compressed to about one fifth the size of an uncompressed file. The data rate is about four megabytes per second. The way in which the data is compressed can vary from one manufacturer to the next. Even though audio/video files for Windows generally have the .avi extension (.mov for Apple), the ability to read (or decompress) these files resides in the hardware or software used for the original compression. The method of compression and subsequent decompression is called a codec. Literally dozens of codecs have been used by various capture card and video editing companies. Microsoft supplies most of the popular codecs, while others can be downloaded from sites on the internet. Still, always keep the original raw videotape if you can. As we move to digital broadcasting, we will be using a new collection of standards. While NTSC stands for the National Television Standards Committee, ATSC stands for Advanced Television Standards Committee. There are many different ATSC standards, all dealing with digital broadcasting. The three basic video formats are SD (1.33 aspect ratio with 720 x 480 non-square pixels and HD, either 720P or 1080i. 720P has 1280 x 720 pixels, while 1080I has 1080x 1920 pixels. HD pixels are square. The aspect ratio is 1.78, or 16 x 9.

Video Sources

Although there are many sources of video, all fall into two categories: electronically generated sources and optical sources. Electronic sources include all of the standard test signals, character generators, computers, and background generators. Optically generated video is produced by television cameras, either directly or prerecorded on videotape.

The electronic test signals are used primarily to set up monitoring equipment and are rarely included in program content. They include color bars, gray scale, dots, crosshatch, and multiburst.



Color Bars

While color bars have several formats, all share a sequence of colors and gray scale values that are fixed and can be used as a standard reference in adjusting equipment. The color sequence is always white, yellow, cyan, green, magenta, red, blue, and black, reading left to right. Each color, going from left to right, has ten per cent less luminance than the preceding color. Using this signal it's possible to set a monitor for the correct contrast and brightness, as well as for the correct color saturation and hue, guaranteeing an optimum picture display. Color bars are often used at the beginning of a program to allow setup of tape processing equipment and playback receivers and monitors.



Gray Scale

Television Production Manual

Gray scale is either a five or a ten step scale plus black used to set up monitors for proper brightness and contrast range.

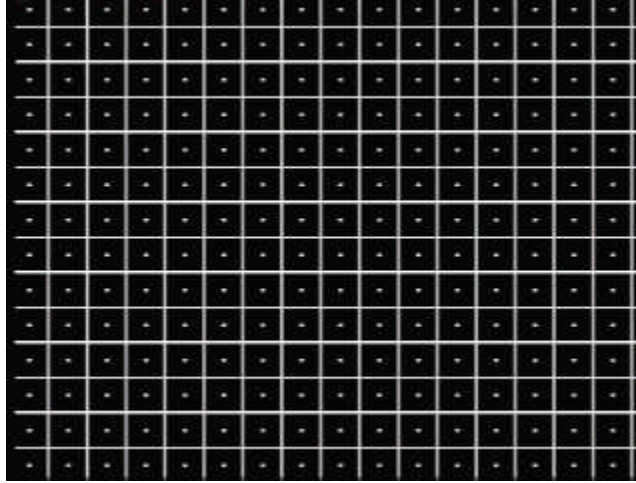

Dots and Crosshatch

Dots is a matrix of white dots on a black background. Crosshatch may be shown as a series of vertical or horizontal lines or as a combination of both. Dots and crosshatch are used to adjust the electron beams in color monitors so that the red, green, and blue signals overlap properly. Neither signal has any burst or chroma content. Crosshatch can also be used to make sure graphics shown by cameras are straight.

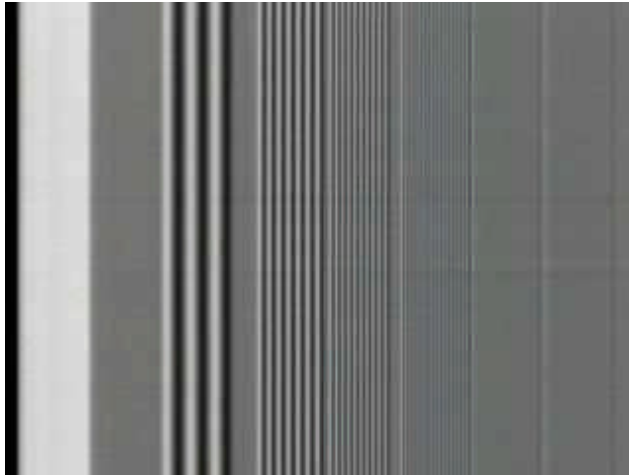

Multiburst

Multiburst is a series of square waves with increasing frequency from left to right. It's used to check the overall frequency response of various pieces of video equipment and is used primarily as an engineering tool. The remaining electronically generated signals are used in the actual production of programs.

Color Black

The most basic is called "color black." This signal has a luminance value of 7.5 IRE and no chroma in the picture. It does have sync and color burst. It's the signal used every time the picture "fades to black."

Color Background

The color background generator provides a solid color background in which the luminance, chroma, and hue can be adjusted. It's normally used as a background for text or graphics displayed on the screen. It's possible to adjust the background generator to create color fields that exceed the technical specifications for video. This results in improper operation of home receivers and should be avoided if at all possible.

Character Generator

The character generator is used to write and display text on the screen. It's actually a microcomputer with the ability to store and display text in a video format compatible with NTSC color signals. Some models provide for the ability to move text horizontally across the bottom of the screen or to roll text from bottom to top. Many character generators also may have the ability to store material on magnetic disks.

Computer

The computer is the tool of choice for artists working on television art and graphics. The ability to capture and digitize live or videotaped images, manipulate them, and store them for later use is essential to almost every television producer. Very few computers produce standard color television signals out of the box. Most common desktop computers can be made to output NTSC-compatible graphics with the addition of a board here and a black box there. The quality of the output is generally proportional to the cost, but effective work can be done with equipment costing only a few thousand dollars.

Artwork done for SD (Standard Definition) television should have an aspect ratio of 1.33. In graphics systems using square pixels the image should be 640 x 480 pixels. In systems using .9 x 1 pixels, the image should be 720 x 480 pixels.

Film Chain

The film chain, for broadcast purposes, is obsolete. A specialized camera is incorporated into the "film chain," a device used to show 35mm slides and motion picture film. This camera is locked in a fixed location. Often it looks at a device called a "multiplexer," which sends one of three optical picture sources to the camera. A mirror is positioned by remote control to select the picture source. Slide projectors normally have two drums or carousels and can "dissolve" from one slide to the next. The film projectors have special shutter systems to adjust the normal film speed of 24 frames per second to the television frame rate of 30 frames per second.

Videotape

Video recorded on tape can be played back through a special computer called a "time base corrector." The signal from a videotape is not very stable compared to live sources, nor is it "locked" to the signal generator which drives all live sources. The time base corrector has the ability to take the picture from a videotape recorder, store it for a very short time, and send it on after adjusting the timing of the signal to conform to other video sources. Time base correctors usually have controls to adjust pedestal (black level), amplitude (gain), chroma amplitude, and chroma shift for color correction, in addition to controls to shift horizontal and vertical timing and the width of the horizontal interval. Tapes played through a time base corrector do, however, have to conform to reasonable technical standards and must have proper sync signals. Many monochrome cameras are incompatible with time base correctors because they lack essential sync signals or process sync in a way that is incompatible with the NTSC color system used in production studios for American television. The most common problems are lack of 2:1 interlace of video fields and lack of equalizing pulses.

Computer Disks

Both CD's and DVD's can be used as data disks with video content. Both can be used in live environments as video sources when connected to a computer with the proper video output. DVD players can be used to play back DVD's or (in some cases) CD's. It is hard to imagine a situation, however, in which it would not be better to introduce the content from a CD or DVD during editing, rather than during the recording of a live event.

Synchronization

Because of the complexity and the technical requirements of the video signal, pictures from different sources can't be combined without first making sure that all sources are synchronized. The biggest challenge in wiring a television control room or edit suite is to make sure that each signal reaching the special effects generator begins a new frame of video at the same time as every other incoming signal. To accomplish this, every color television facility

Television Production Manual

uses a signal generator which provides timing signals to all video equipment which must interact. In addition, all signals must arrive with the color reference, or burst, at the same phase angle as all other signals.

Some cameras and recorders can't be locked to an external sync source. Those that can use either video or three discrete synchronizing signals. Those that use video have a "genloc" input which is used to lock an internal sync generator to the incoming signal. Those requiring discrete synchronizing signals use vertical drive, horizontal drive, subcarrier, and perhaps composite sync, produced by a special signal generator.

Timing and phase errors between sources are potential causes of bad pictures. If a picture problem is unique to a dissolve, wipe, or key situation, timing and color phase are possible causes.

There are a number of issues related to signal timing that keep television engineers busy. Just knowing that timing is important any time you connect or mix the outputs of two video devices should be enough to alert you to the cause of many otherwise mysterious problems.

Monitoring

Waveform Monitor

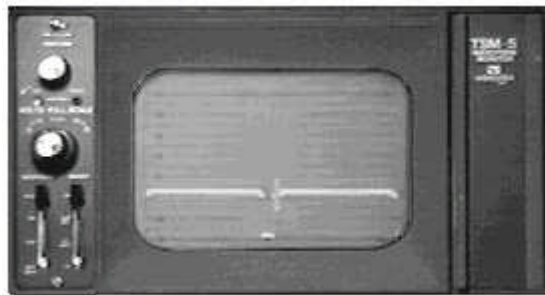

In judging pedestal and gain, and technical signal quality, a special oscilloscope called a waveform monitor is used. This monitor has a number of operating modes, but the most commonly used gives a display of two horizontal lines of picture, showing the combined effect of both the luminance and chroma portions of the picture. It's calibrated in IRE units, from -40 IRE to 100, so precise measurement of the amplitude of both sync and picture is possible. It's also possible to isolate either the luminance portion or the chroma portion of the picture and to look at the horizontal sync portion alone, the vertical sync portion alone, or at two fields of video. Waveform monitors are valuable tools in evaluating the timing and technical quality of video

sources and are therefore useful as trouble-shooting tools as well as production aids.

As you know, the amplitude of the video signal is set at one volt peak-to-peak into an impedance of 75 ohms. A glance at the waveform monitor can reveal one of the most common technical problems in television. Many devices allow you to "loop" an input through one device to another. Picture monitors generally allow you to do this. They also have a termination switch next to the looped input. Along the line from your picture source only one device should be terminated. A second termination will cut the signal amplitude in half. Lack of any termination will double the amplitude. If the sync portion of the composite signal on the waveform monitor is either much larger or much smaller than -40 IRE, the problem is almost always improper termination.

Vectorscope

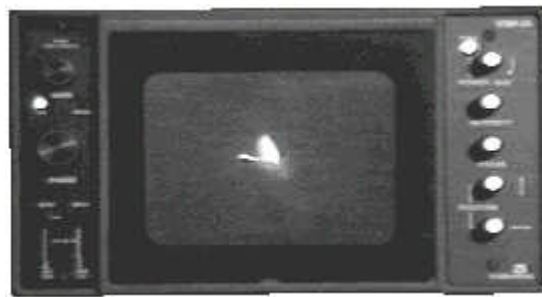

The vectorscope is used in analyzing the color content of the video signal. It's set up like a polar graph, showing hue as a phase angle with reference to the "burst" signal, which should always be at zero degrees. Amplitude (distance from the center) of a color indicates the saturation of the color. One of the main functions of the vectorscope is the adjustment of color phase of all color video sources in the system. Using a standard reference signal, usually the color subcarrier or color black, each color source is examined and the phase angle of its "burst" signal adjusted to zero degrees with reference to the standard signal. Only if all sources are "in phase" can they be used in special effects such as wipes and dissolves without objectionable color shifts. The vectorscope is also useful in evaluating the accuracy of color rendition of cameras and in setting up color background fields.

Meters

Finally, videotape recorders and some other devices have video meters. These are not nearly as precise as the waveform monitor, but can be used to confirm

the presence of a video signal and whether that signal is in a reasonable range. Although these meters may not have any calibration scale indicated, they do have a colored section which conforms to a reasonable video level for most color signals. The most obvious exception to this is color black which gives a meter reading well below the "optimum" level. Video meters have only limited usefulness.

Switching

The heart of any video control room is the special effects generator, or video switcher. This is the device used to select pictures from the various video sources and to create the effects which are the "language" of television. While the average video switcher offers a bewildering number of possible effects, it's usually laid out in a logical and functional manner easily mastered if it's taken one step at a time.

The most common special effect is the "take." It's the instantaneous change from one picture source to another. The reason it's the most common is that it's almost always the most appropriate way to change picture content in the course of a program. It may seem strange to use such an imposing piece of equipment as a video switcher for such a simple task, but it's crucial for any director to remember that all of the equipment around him serves only one central purpose: to transmit information to his audience cleanly and without confusion or distraction. The program content must carry and maintain the interest of his audience. Any attempt to "dress up" a program with unnecessary effects will simply distract or confuse the audience and will, therefore, be self-defeating. There is a video "language," just as there is a film language and just as there are spoken and written languages. In all of these it's the ability to communicate clearly that is the mark of the literate person.

The next commonly used effect is the dissolve. This is a gradual cross-fade from one picture to another during which one picture is superimposed on the other. The speed of the dissolve should be determined by the pace and mood of the program material. The dissolve can be used to establish or enhance a lyrical mood. But it can also be used for major transitions in program content that need to be softened; that is, where a take would be too jarring. Often a dissolve is used to indicate the passage of time or a change of location in dramatic programs. In other contexts, it might be used in transition from a wide shot to a close-up to emphasize continuity.

The wipe has less ambiguous uses. When a complete wipe occurs, one picture is replaced by another as though it were pushing the other off of the screen. Most switchers offer a number of wipe patterns, including horizontal, vertical, various corners, circles, and perhaps some others of limited usefulness. The wipe is used in two ways. First, it's used to insert a portion of

one picture into another, allowing the viewer to see two scenes at the same time. The wipe is sometimes used in the same way as the dissolve to indicate a change in time or location.

Keys and mattes are used to insert one picture into another. Luminance keys use the monochrome signal as a switching device. Any portion of the keyed signal reaching a specific video level replaces the video content of the background signal. The amount of luminance necessary to effect this replacement is adjusted to achieve the desired effect. A matte is similar to a key, except that a solid color from the background generator is inserted into the background video in place of the video from the key source. Chroma keys work on the same principle, but use the color saturation of a specific hue as the keying signal rather than the luminance level.

Luminance keys and mattes are used almost exclusively to superimpose text or graphics on the screen. A character generator, for example, uses a luminance key to put text over normal video. Chroma keys are used to insert more complicated video into the background. Because of the wide range of luminance values in video containing people or objects, a clean luminance key is often impossible. By carefully controlling the hues in a scene, though, it's often possible to generate a clean chroma key. The most common color used in chroma keys is deep blue. The most common use of chroma keys is the insertion of video tape or computer graphics into newscasts.

Organization of Materials

The materials needed to produce a television program fall into two broad categories. The first consists of the material itself, including the script, on-camera talent, sets, and props. The second consists of the videotape, equipment, and crew which will be involved in production. It's the job of the producer to see to it that both come together at the time of production. Even if you're just shooting home movies, you can appreciate the difficulty in getting the "cast" and your equipment together and ready all at the same time. In the world of professional film and video the problems are the same, only bigger.

Planning and pre-production

The first step in planning a production is usually called a "treatment." This is nothing more than a brief description of the way the material is to be organized and the programmatic goals of the production. For example:

This program is designed to present the services provided by Moving Pictures, including program production, tape duplication, and computer graphics and animation.

This might be followed by an outline showing sequences in the order in which they will appear in the final program and detailing the objectives for each sequence.

- I. Open with variety of location shots.
- II. Brief description of range of services.
- III. POC explains advantages of television over other media.
- IV. Examples of too small - too large - too far away - too dangerous concepts.
- V. Examples of narrations in different languages.
- VI. Computer animation and graphics examples
- VIII. Closing statement

Television Production Manual

The next step is a shot sheet, or storyboard. While a shot sheet describes each shot in writing, a storyboard does the same thing using pictures.



1. Aerial WS of Champaign-Urbana



2. Key "Moving Pictures " over aerial shot



3. MWS POC in Vesuvius shop



4. WS Antique fire

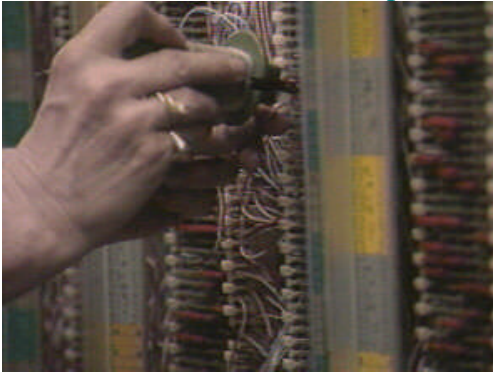

5. CU wiring installation



6. WS of special "easy to ride"



7. "Time Pinnacle" laser light show

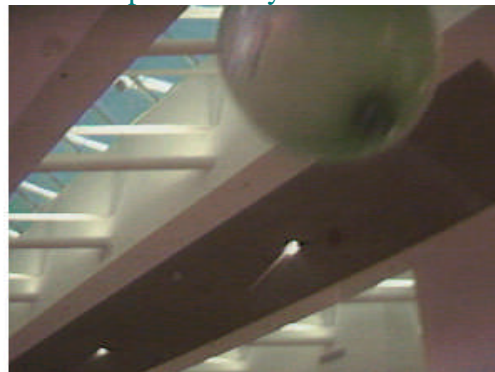

8. WS Skylights in Danville Village Mall.

Television Production Manual

While these storyboard frames were taken from actual video, pictures can be stick figures, cartoons, or (in some cases) professionally painted panels. If it works, it's just fine.

Finally, a full script may be written, containing all of the audio and video information to be presented in the program.

TITLE:	DRAFT NO:	PAGE NO:
PRODUCER:	VIDEO	AUDIO
Copyright Warning		
CU aerial shot		MUSIC UP
Key MP Production & Services Music. over CU aerial shot		
POC at Vesuvius intro		
Fire truck in parade		
Wiring, Ill Bell Champaign office		MUSIC UNDER
WS of special "easy to ride" bicycle at Parkland College		
"Time Pinnacle" laser show		
WS Skylights in Danville Village Mall.		NARRATOR: MOVING PICTURES is a television production company. We make television programs for business and government. We also provide a full range of services related to making and showing television programs, from tape duplication to consulting to designing and building both production and playback facilities.
MP at Business Expo		
Danville Village Mall		
Key over stack of labeled tapes		
Tape Duplication		
Facilities Design for Production Playback		
POC in edit suite		POC: At MOVING PICTURES we make pictures that move; images on videotape that move in the literal sense, but also move your audience to understanding or to action. You have a number of ways to communicate with your various audiences;

Television Production Manual

Not all of these steps are appropriate to every production. In electronic field production the producer will scout each location involved to determine whether lights will be needed, whether sufficient power is available, how any lights will be placed, where the camera will be set up, and how sound recording will be handled. He should visualize each shot, making sure any problems can be overcome and ensuring that the shot will fit into the program without breaking any of the rules of continuity.

For any production that might be shown to the public, the producer should get permission to use each location and make sure that he has a release form for each person he intends to use as on-camera talent at each location. People appearing incidentally in a shot need not sign release forms, provided the taping is done openly in a public place. Even when taping in public places it is a good idea to inform concerned authorities of your intentions to avoid any misunderstandings or problems such as crowd control or interference with other activities at the same location.

If the script calls for the use of any potentially copyrighted materials, it is the responsibility of the producer to acquire the right to use the material, or, failing that, find substitute material for which he can acquire rights. It's important for the producer to anticipate his distribution needs when buying rights, since he could find he has the rights to distribute in one way and needs to distribute in another. For example, having performance rights for a play is not the same as having recording rights to turn it into a television program. And owning a recording of a song in no way gives you the right to use that recording as a part of a program. Special rights called "synchronization rights" are needed to do that.

Additional Video

***NOTE:** Of all the chapters in this handbook, this is most subject to change as television production moves from the use of tangible forms of image storage, such as slides or prints, to electronic storage. While slides and prints are still important sources of pictorial images, in the generation and use of titles and text, I have not used or even seen anything other than computer-generated text since the mid nineteen eighties.*

RJI

Titles and Artwork

Graphic material is very important in many types of programs. Certainly almost any sort of show looks more polished and professional if it has, at least, opening titles, and credits for the major members of the production crew at the end. Other types of written and graphic material may also be needed.

There are four main ways to incorporate graphic information into a television program.

The **CHARACTER GENERATOR** is a computer that produces printed material digitally and converts it into a form which is directly usable as a video source.

Graphics can also be produced on **LIVE CARDS**, usually cardboard sheets about 11 x 14 inches, which are shot by a camera.

SLIDES can be produced photographically in a variety of ways from the same sort of originals used for live cards and can then be projected into a special camera using a device called a film chain or projected onto a white surface and shot by a camera.

COMPUTERs are used to generate most of the graphics now used in television at all levels.

Character Generator

Character generators differ significantly in their versatility and ease of use, but mostly tend to look the same, consisting of a console with a typewriter-style keyboard and, usually, a dedicated video monitor. There are a number of special keys on the keyboard which control specific functions of the character generator, such as page advance, character size and type style, automatic centering, and perhaps other options. There is always a set of keys to position (up, down, left, right) a cursor which appears on the character generator's own monitor (but not in the signal sent to the switcher) and indicates exactly where on the screen the next letter will appear.

Most character generators allow for only a small number of characters on the screen at once; ten lines of thirty figures each is typical. Actually, this isn't a disadvantage. Small characters are difficult to see given the limited resolution and large viewing distances of TV sets in the home. This general principle applies to all graphics work for television: keep it simple, make all important elements large, and try to present complicated graphics in several pages, if needed, instead of all at once. The output of a character generator is usually inserted over other video by means of a key or matte.

As character generators become more sophisticated (and expensive), they may offer some of these additional features: Most units can store more than one "page" of graphics and allow you to recall them in order, or randomly, by pressing keys. The ability to roll (vertically) or crawl (horizontally) lettering across the screen is useful; rolling credits are common at the ends of programs, and crawls are often used to make announcements during a program at the bottom of the screen. Some machines offer a disk or tape cassette storage system which allows pages of characters to be stored for recall at any time, also extending the page-storage capability of the character generator enormously. Finally, more sophisticated character generators offer a wide variety of sizes and styles (and sometimes colors) of characters, variable italicization, outlines, shadows, and even the ability to create custom characters or logos for regeneration later. Less expensive machines may offer only one or two sizes of a single type font; the very cheapest don't even have lower-case letters.

The major disadvantage in the use of character generators for television graphics is that they are at their best only when presenting rather simple textual information. If you have in mind any kind of charts or graphs, or the use of some special type style, you'll have to use something else.

Live Cards

Television Production Manual

Before computer graphics we used live artwork cards in front of a camera to present graphics and photographs. Modestly stiff multi-ply cardboard in cards about 11 by 14 inches were the most common background material for live cards. This material is available at art supply houses in a variety of colors and textures.

Lettering on live cards can be done with dry transfer letters, again available at art and school supply stores. This material is provided in large sheets containing several complete alphabets of a particular type font. There are other lettering systems too, sometimes faster or cheaper but seldom as good-looking as well done dry transfer work.

In making up live cards, it's important to assure that everything you need will be seen on the television screen and that no extraneous material gets in. Always allow a 1-1/2 to 2 inch border on all sides of a live card to give some leeway in camera positioning and framing. This area should be completely clear of dirt, pencil marks and other distractions, as should, of course, the main picture area itself. Also, remember that the dimensions of the television screen are four units wide by three units high. A six by eight inch area in the center of an 11 by 14 card would be a very safe one in which to compose your graphics. Usually type no smaller than 24 point (1/3 inch high) would be used in a space of that size.

Slides

Any 35 mm still camera can be used to generate slides for use in television. In any photographic work for television, remember that the television system always crops the image slightly, so you'll see less on the TV screen than appears in the original slide or film. The 35 mm slide format also has a slightly different aspect ratio than the TV screen; the pictures are wider. Thus, anything at the extreme edges of the picture will not be reproduced.

Digital still cameras normally have a 1.33 aspect ratio and almost all have more than the 640 x 480 pixels used in SD television graphics.

It's wise to allow a border of about 20% of the picture area on each side when framing in the still camera's viewfinder to allow for this image cutoff. This same precaution applies when shooting live-action photographs for use in television. Some very expensive 35 mm cameras have interchangeable focusing screens and make available a screen marked with the appropriate television "safety" areas.

Television Production Manual

Here are the most important restrictions on the use of still photographs in television:

1. Observe the safe action area. As mentioned above, a border of about 20 percent is needed. For a quick and conservative approach, turn a 35 mm camera on its side, as if shooting a vertical-format picture. The area seen from right to left in the viewfinder can be reasonably expected to be seen in the video image after you turn the camera back for the horizontally-framed shot.
2. Shoot only in horizontal format. Vertical slides appear on TV with severe cutoff at top and bottom and with a black border on each edge.
3. Keep contrast low. Pictures taken in bright sunlight without additional fill light, or indoors with a single flash unit, are often too high in contrast to reproduce properly on television (although they may look fine when projected on a screen). You should try to follow the same rules for lighting still photographs taken for television that you would in lighting for a video camera itself.

Film

It's not as easy to use film in television as it seems it ought to be. Two problems arise. First, film is usually shot without any regard for the television safe action and title areas. The outside 20% or so of the film image is lost in the transfer process. Second, film is shot at 16, 18 or 24 frames per second. Broadcast film chains use special shutters in their projectors to repeat every fourth frame, bringing the frame rate up from twenty-four to the thirty frames per second required for television. Film shot at sixteen or eighteen frames per second can't be synchronized to television without special projection equipment.

Not so long ago virtually every television station had a film chain, both for news film and for theatrical films. Now they are rare indeed. To use film in a video production you will almost certainly have to convert it to video at a photo store or duplicator that has the necessary equipment. The transfer should be made to digital video if possible.

Computers

Computers can be used to generate television graphics in live productions if their output signals are adapted to the NTSC standard. Most often computer

graphics are integrated into programs during editing using nonlinear editing programs.

Computer screen outputs differ from standard NTSC video in several ways. First, most are "non-interlace." That is, there is no division of the picture into alternating odd-line and even-line fields. Second, the rate at which frames are displayed is usually much faster than the nominal thirty frames per second used in television. And third, many computer graphics displays leave a fairly large border, or "safe area," around the active graphics area. The television video area fills the entire screen. Although a variety of add-on products might allow recording of computer images on videotape, conversion to actual broadcast television standards requires a special video card. Even still images on computer take up a lot of space. Each true broadcast-quality image requires about one million bytes to display. To make transfer and storage of video images more practical, two basic compression techniques have been developed, with more on the way.

JPEG compression deals with discrete images, one at a time. Typical video frames can be compressed to one seventh of their original size with no discernable reduction in quality. It is usually possible in using JPEG compression to specify the degree of compression desired, so noticeable image degradation can be avoided.

MPEG compression works on the assumption that much of the image from one frame to the next in film or video remains the same. Except for key frames, no single MPEG frame is complete and each has meaning only with reference to the frame that preceded it.

Some additional observations on computer-based video can be found in the Editing section.

Rights and Responsibilities

Television, more than any other medium, by nature can invade the privacy and trample on the rights of the people it uses. The television producer makes himself responsible to the people shown on camera and to the creators of materials he might use. He must also guarantee that he will use his medium responsibly and fairly. The ability to make and distribute television programs depends largely on the continuing trust these people have for the producer and his crew.

Rights can be divided broadly into those involving people who actually appear on camera and those involving the acquisition and use of the creative works of others. The two sometimes overlap when musical or dramatic performances are involved. Both need to be given careful attention.

People on camera

In certain kinds of programs everyone who appears on camera does so by choice. This doesn't necessarily give the producer the free and clear right to use recordings made under these circumstances in any way he pleases. First, those appearing should be informed of the intended use of the recording and its potential distribution. Understanding the producer's intentions, they should then give the producer permission to carry out those intentions by signing a "release form" stating the intent of the producer and any compensation to be received by the performer.

In other programs, people may be videotaped without permission. This may be done if the following conditions are met:

1. The taping is done in a public place.
2. No attempt is made to hide the fact that a recording is being made.

In any case, a person appearing on camera is in the hands of the producer, who has certain responsibilities toward him:

1. To respect any verbal promises or understandings made at the time the recording was made.
2. To refrain from using or editing the material in a way that alters the meaning of any statements made by the person appearing.

Television Production Manual

2. To refrain from editing the material in such a way as to misrepresent the circumstances of the recording in a way detrimental to the person appearing.
3. To refrain from distributing the material beyond the distribution agreed to and stated in the release form.

A talent release can be anything from the simple form below to a contract running hundreds of pages. It all depends on the complexity of the issues and the need to guard against unforeseen circumstances. This sample is a simple expression of good faith by both parties.

Television Production Manual

Sample release form:

General Release

In consideration of the payment to me of the sum of \$_____, receipt whereof is hereby acknowledged, I hereby agree as follows:

1. I give and grant for a period of_____years (hereinafter referred to as the "Term") to MOVING PICTURES, its successors and assigns, the right to use, publish, and copyright my name, picture, portrait and likeness in a television program produced by MOVING PICTURES_____and in all media and types of advertising and promotion of the above program.
2. I agree that all videotape of me used and taken by MOVING PICTURES is owned by them and that they may copyright material containing same. If I should receive any copy thereof, I shall not authorize its use by anyone else.
3. I agree that no material need be submitted to me for any further approval and that MOVING PICTURES shall be without liability to me resulting from the publication of my likeness.
4. I warrant and represent that this license does not in any way conflict with any existing commitment on my part.
5. Nothing herein will constitute any obligation of MOVING PICTURES to make any use of any of the rights set forth herein.

(Signature) (Date)

(Printed Full Name)

(Address)

If releasor is not yet 21 years old, complete the following form:

I, the undersigned, hereby warrant that I am_____ *of_____, a minor, and have full authority to authorize the above release which I have read and approved. I hereby release and agree to indemnify MOVING PICTURES and their successors and assigns, from and against any and all liability arising out of the exercise of the rights granted by the above release.

(Signature of Parent or Guardian) (Date)

*Insert the word "parent" or "guardian," as appropriate.

In addition, it's important to respect the wishes of people who appear on camera. It's possible, for example, that a person recorded during a traumatic event might later decide to ask that he not be used in your program. Unless you can make a good case for the importance of that person's appearance, it would be wise to accede to his wishes. It's also a common courtesy to allow people appearing in your programs to preview material before it's shown in public. While this does not suggest that they have any right to edit or control your product, they may be able to make suggestions for changes that would improve the accuracy or impact of a program.

You also have an obligation to be fair in your treatment of issues. The composition of every shot, as well as its duration, is an editorial judgment. The process of selecting and rejecting sequences for inclusion, too, implies editorial judgments. If you have a bias or an axe to grind, get it out front both in dealing with those who appear in your program and in presenting it to your audience. No one is free of all bias, but in the communications media you have a special responsibility to the public to deal honestly and fairly with facts and with issues, as well as with people.

Copyright

Copyright is the great two-edged sword everyone in the media must face sooner or later. In copyright, as in most areas of law, the more you know the more confusing it can become. Far from being legal advice, what follows is intended to let you know when to start asking the hard questions and not to lull you into a false sense of security.

Copyright is designed to foster the creation and publication of ideas by allowing the author to sell his ideas on the open market. It's thought that only if the creative process can provide economic rewards to creative people can the maximum flow of ideas be promoted. Thus, to deprive an author of his right to earn money by selling his product, whether a photograph, book, song, or videotape, harms us all by discouraging him from publishing his work.

Any use of a copyrighted work without the copyright holder's permission is an infringement of his rights. In certain cases, however, such use can be defended using the principles of "fair use." This basically means that the use will not cause financial injury to the author and that the need of the public to have use of the material can be demonstrated to be more important than the author's right to protect his creative work. Except in broadcast news and educational situations there is little point in considering "fair use" further.

The proliferation of home recorders (both video and audio) has created a right to record materials for personal, private use. You do not have the right to

Television Production Manual

"distribute, duplicate, or perform (present to an audience)" your home recordings except under very limited fair use guidelines. There are limited exceptions for educational use, but whether you make a profit violating someone else's copyright is irrelevant. The mere fact that you're not making any money does not give you permission to break the law.

A perfect (and common) technical violation of copyright takes place when you videotape your child's performance in a school concert or play. As long as the recording is for personal use only this kind of taping is permissible. If the recording will be used by the participants as part of their training it's okay. Again, any public performance, distribution, or duplication of your private copy (outside your immediate family) creates a real copyright violation.

The number one copyright rule is not to step on someone else's toes. It must be assumed that anything printed or published or shown is protected by copyright. This isn't literally true, but it's better to assume a work is protected until you can prove otherwise than to infringe on someone's copyright. Virtually everything in print is copyrighted. Most music, whether in sheet form or recorded is also protected. Broadcast radio and television stations pay a licensing fee to ASCAP and BMI for the right to use music on the air. Since you don't have a license to use copyrighted music, you'll have to resort to one of three alternatives: write and perform your own, buy limited rights for a specific recording or song, or buy a record library which you can use without restriction.

Dramatic works are a problem in that there are two considerations beyond merely purchasing rights. Not only will the licensing agent make sure your "performance" of a work won't conflict with any theatrical production in the same region of the country, but the agent may feel that a videotape recording of a work might, by virtue of its amateurish performance, actually harm the reputation of the work and deny permission on that ground alone. This is also true of short stories and novels, where the author has a legitimate right to impose conditions on adaptations of his work. Regardless of the type of work involved, the best way to find out who has the rights and how to acquire them is to write to the publisher of the work.

On the brighter side, as a creator of television programs, you are also protected from copyright infringement. In order to obtain protection, you should place a copyright notice prominently on your work. On a script or book it should appear on or near the title page. On a film or videotape the notice may appear at the beginning or end, as long as a viewer is likely to see it. Although an explicit copyright notice is no longer required by law, if you publish or distribute a work without a copyright notice you may give the

Television Production Manual

impression you do not intend to protect your rights and are implicitly placing the work in the public domain.

You can register your copyright with the Register of Copyrights, Library of Congress. In practice this is rarely done. You can file your copyright at any time. Usually actual applications are made only if the copyright holder intends to sue someone for infringement. Obviously, the copyright has to be registered before such a suit can be brought.

In summary, a reasonable respect for the rights of people you deal with in the production of television programs is perhaps the most important single responsibility you have as a television producer. Respect for the rights of others will pave the way for your own work and the work of those who follow you. On the other hand, a disregard for the rights of others will make people reluctant to work with you, on or off camera, and close doors for everyone who depends on the good will of the public.

Taking it to the next level

If you intend to distribute your work commercially or have large quantities made by a commercial replicator you will want to take special care in documenting your rights. Many replicators are members of the International Recording Media Association. As one of the conditions of membership, these companies will require you to fill out a form supplied by the association (and available on their web site at www.recordingmedia.org) and to provide documentation of the rights and permissions related to your project. If you are using pre-recorded music you must be able to produce proof that you have the right to use the music. This could take the form of a copy of your original contract with the music distributor, such as a “buy out” license or a letter from the distributor verifying your rights. If your audio is licensed separately you will need proof of audio/video synchronization licensing. For CD's containing special software to make them play back like DVD's you will need distribution licensing documentation for the software. You should be able to affirm that you have all of the releases necessary for your talent and permission to use any other copyrighted materials. Needless to say, it is much easier to keep track of all of your paperwork as you go along than it is to assemble it after the fact.

Editing and Program Continuity

Editing a television program is much more than just putting shots together on a single piece of tape so they can be viewed as a whole. It is in the editing phase that a production is finally made to conform to the producer's vision of it. Editing is both the last and one of the most powerful opportunities the producer has to influence whether a program will communicate the information it was meant to convey successfully, and whether it will affect the emotions and moods of the audience as the producer wished. The editing process is also a difficult and demanding craft, and presents many opportunities for the unprepared to go astray. Indeed, the failure to communicate effectively in many beginners' television programs is much more often a failure of the editor to develop a coherent conception of the flow of the program than of any problem with other technical aspects of the art of television, such as camera work or sound recording.

Conversely, it is possible for a skilled editor to take even seriously flawed original footage and produce a program which still manages to say what the writer and director had in mind - but we certainly hope you will never be forced to work that way.

In commercial television and film production, the "shooting ratio," or amount of film or tape shot divided by the length of the finished program, averages about 10:1. In other words, for every minute of edited program you see, ten minutes or more of tape was recorded by the camera crew. In some specialized and difficult programs the ratio routinely climbs above 100:1. On the other hand, in live television production in the relatively comfortable atmosphere of a studio, it is often possible to use every second of the original recording with a shooting ratio of 1:1.

Actually both of these represent extremes which you will not ordinarily encounter. Ways to reduce editing time include keeping the overall shooting ratio as low as practical, grouping scenes shot in the same place or time together on the original tape, and, when possible, "slating" shots by holding up a card in front of the camera showing the place, time, date, and crew members present and any other information you think may be helpful in identifying material later.

Television Production Manual

You may have inferred from the above that the process of editing in a sense begins long before any tape is recorded. In those productions which are scripted in detail before shooting, the script may in fact dictate almost exactly how the finished program will be edited. So a knowledge of some of the rules of visual and aural continuity is as essential for the script writer, director, and camera operator as for the editor. Again, the more planning and preparation before entering the editing room, the less time and money spent there. Even if your program doesn't lend itself well to detailed scripting in advance, it is usually possible to write up an outline, or perhaps even an exact "editing script," based on several viewings of the original footage, which can guide the editor in putting things together properly in the minimum amount of time. This is not to imply that many decisions won't have to be made during the process of editing - especially the specifics of exactly on which frame to make cuts - but good planning can make the actual work with the editing machines much quicker and more pleasant.

There are basically three purposes in editing a program. They are:

1. To eliminate material which is unusable because it is technically flawed;
2. To remove footage which is irrelevant to the information to be presented in the program;
3. To assemble what is left in a way which communicates the important information in the program and, at worst, the editing isn't distracting to viewers and, at best, the program is both interesting and entertaining.

There is almost never a justifiable reason for making a program longer than the absolute minimum necessary to cover the topic adequately. If in doubt about the relevance of a particular shot or sequence, it is almost always better to leave it out. Keep cutting away at what you have available (while watching the shooting ratio soar) until every frame of the remaining tape has something valuable to say. Your audience will be grateful for it, and may reward you by staying awake through the whole program.

What follows is a selection of various rules and concepts of editing which have been developed through experience over the last century of editing motion pictures and, more recently, television programs. The rules are, to some degree, flexible, but they should be violated blatantly only with great trepidation and after carefully considering all of the alternate ways of editing the sequence. However, if you have something important to say, and only unconventional editing will communicate it effectively, then the content should take precedence over any editing rules. Remember, your final consideration is your audience and their reactions.

WS - MS - CU sequences; using close-ups

Beginning television news camera people are always taught to take three shots of each subject, using different distances, angles, or lens settings to yield a long shot, medium shot, and close-up of the subject. Then these three pieces of tape are edited together in that order to give the viewer an impression of moving in on the action from the outside, finally becoming involved (through the close-ups) in the action itself. Watch television news coverage of a fire or similar event the next time you can. Typically, you'll see something like:

LONG SHOT, the burning building;

MEDIUM SHOT, firefighters pulling hoses off the truck and carrying them toward the fire;

CLOSE-UP, firefighter's face or hands as he wrestles with the hose.

Additional shots would tend to be more close-ups: equipment on the truck, hands holding the hose, the faces of spectators, etc. At some time, determined by the pacing of the editing and, in this case, the severity of the fire, there might be a return to the long shot to reestablish the overall layout of the scene in the viewer's mind.

Notice the emphasis on close-ups. Television is a relatively low-definition medium, and subjects seen in medium shots or wider just don't come across powerfully on a television screen. It is details, sometimes shot at very close distances, which are most effective in adding visual interest to a story. Use close shots - details of objects, a person's surroundings, or especially of the human face - whenever it is possible and meaningful to do so. They do more than anything else to add excitement and interest to your program.

As the amount of information on the screen decreases, so does the viewer's ability to watch it for a long time. This implies that close-ups, which contain relatively little visual information but spread it over the entire area of the screen, shouldn't be held on the screen for a very long time. When presented with a single detail of something, an audience can look at it for no more than three or four seconds before it becomes bored and turns away. Exceptions to this rule occur when there is something going on to maintain interest. For example, moving objects can be held longer than totally inanimate ones. A narrator heard in a voice over may point out interesting details in what is shown so that the audience is continually discovering new aspects of the picture. In these cases, even extreme close-ups can remain on the screen for a relatively long time.

Close-ups of faces, on the other hand, can be held for along time, as we seem to find endless fascination in that particular subject. Close-ups are very powerful and revealing for interviews and tend to give at least the illusion of great insight into the speaker.

By contrast, long and medium shots are used less in television, although they certainly have a very important place in most programs. The audience can become disoriented if they are not occasionally reminded of where they are, the overall arrangement of objects and people in the location and the relationships between them. This is the purpose of the long shot. Medium shots reveal more about a single subject, without the emotional commitment of a close-up and they are also most often used for showing the progress of action, as in our fire example above. Of course, there are an infinite number of possible variations. It is the subject matter and overall mood and structure of your program which determine in the end how sequences of different angles views will fit together.

Jump cuts and the thirty degree rule

One of the most distracting mistakes it is possible to make in editing is called a "jump cut." If you've watched commercial television all you life, you may in fact never have seen a jump cut. They are so visually distracting, and such pains are taken to avoid them, that this particular error almost never makes it to your home screen.

A jump cut happens when you attempt to edit together two shots which are too similar in visual content. The most obvious example might occur if you remove a single sentence from an interview shot while the camera (which recorded the interview originally as a single shot) remained static. What would happen is that the background would remain still, while the subject's head might "jump" a bit to one side, or lips which were closed might appear instantly to open.

The result is a very jarring interruption in the otherwise smooth flow of action. There are several solutions to this problem. In the case of the interview, an appropriate response would be a cutaway shot - about which more will be said later. In other situations application of the "rule of thirty degrees" can help.



The Thirty-degree Rule

The thirty degree rule states that if you make sure that the angle of view of the camera to the subject changes by thirty degrees or more between two shots cut together, the background will move enough that the shots will cut together well without any apparent visual discontinuity. The diagram below illustrates the rule. Failure to move the camera at least thirty degrees between shots almost invariably leads to a jump cut. There are exceptions, of course. Cutting from a medium shot to a close-up, for example, can be done even if the camera is not moved an inch. The point is to make each shot as visually different from the one preceding it as possible, so that the viewer's point of view of the scene appears to change in a natural manner. Notice that if you invariably follow the long shot - medium shot - close-up sequence suggested earlier, the problem of jump cuts caused by violations of the thirty degree rule never develops. And cutting from one subject to an entirely different one, or from one location to another, rarely presents any problems. There are other types of visual discontinuities you must guard against. Most of these are essentially the responsibility of the camera crew at the time of shooting, and the editor's only involvement is to try to cover them up when they occur.

Errors of this sort usually creep in when shooting is spread out over several hours, days, or months. A typical problem might be shooting part of an interview one day, then coming back a few days later to get additional material and finding the subject dressed in different clothing. (Invariably the clothes the subject wore the first time will be in the laundry and totally unavailable.) You can't cut together parts of the two interviews without making it look as though the subject instantly changed clothes. Errors like these can only be avoided if you are aware of them and plan around their occurrence. It is also among the editor's responsibilities to point out continuity problems when they occur, so that a way can be found to avoid them or minimize their effects. (For example, in this case, it might be possible to group the footage in such a way that the clothing appears to change during

a long interlude while other subjects are being shown. When the action returns to the interview the change won't be obvious.)

Direction of motion and the 180 degree rule

By this time you may think that editors and directors have to be experts in geometry. Not so! There is really only one other "angle rule," which is designed to keep people facing and moving in the same direction on the screen. One of the more distressing visual discontinuities is reversal in direction of motion, or in screen position of people. An example:

Someone walks out of one room and into another. In the first shot, you set up the camera in the middle of the first room and the subject walks from the left side of the screen and exits through a door on the right. Now on entering the second room, into which the subject is to walk, you find a large expanse of windows on one wall, with the door on the left as you face them. You don't want to shoot into those bright windows, as the camera will give you a poor picture, so you set up the camera on the window side of the room looking toward the middle. Now the subject walks in, but this time **WILL BE ENTERING FROM THE RIGHT SIDE OF THE SCREEN**. When this is edited together with the previous shot, it will look like the subject changed direction in mid-stride.

The solution is to keep the camera always on the same side of the moving subject. If something is traveling from left to right, it should continue to go in the same direction in every shot you think might be edited into the same sequence. Sometimes, as in our window example, this takes considerable pre-planning and can be something of a headache if there are many locations involved. But it is necessary if the audience is to be able to follow the action without confusion. Again, if you just can't think of any other way, a cutaway may be used between two shots where the action reverses direction. But this technique is all too obvious to the viewer much of the time.

A somewhat related situation arises when you are dealing with multiple subjects, perhaps in a discussion situation. It is necessary to arrange your shots, and their editing, so that subjects don't appear to be moving from one side of the screen to the other, or looking in different directions at different times.

Study the diagram below, which represents a simple situation with two people seated at a table. If the camera always stays in the area indicated by the number "1" no matter what two shots you cut together, subject "A" will be looking toward the right side of the screen at subject "B," who faces left. This will result in proper visual continuity.

The 180 Degree Rule

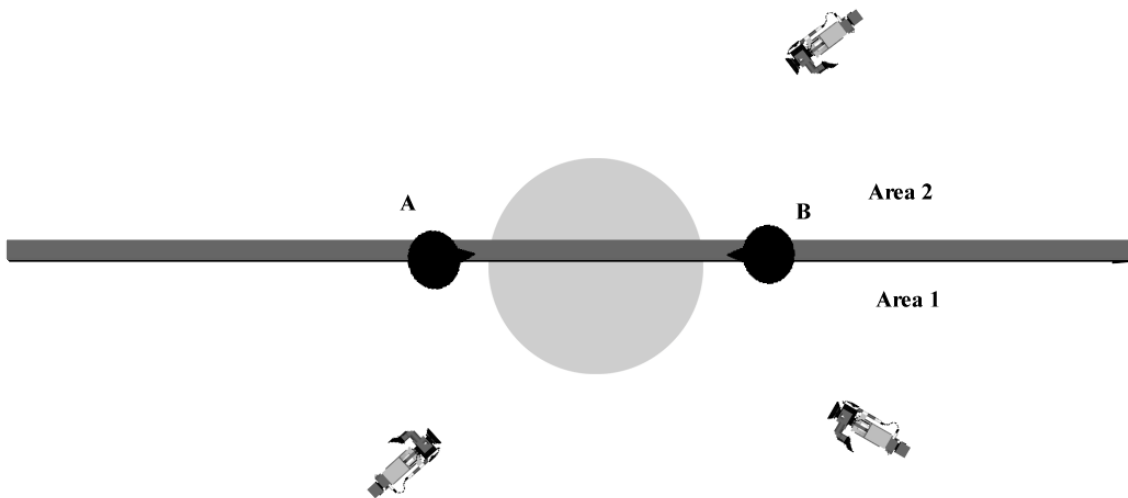

If, however, the camera crosses over to the other side of the table, the apparent positions of the two subjects will be reversed. If you cut two shots of "B" together in succession, "B" will suddenly appear to be looking at himself, but from opposite directions.

This is called the 180 degree rule. When dealing with two or more subjects, visualize a straight line drawn through both of them. As long as the camera always stays on one side or the other of this line, apparent visual continuity can be maintained. The name derives from the fact that the camera can move through an arc of 180 degrees relative to the center point between the subjects.

Now remember the thirty degree rule. We have set up a situation in which, in order to maintain effective visual continuity, the camera has to move at least thirty degrees between shots but has an overall field of only 180 degrees to work in. It can be frustrating, to say the least, to the editor who has to work with material shot without regard for these two rules. Yet the editor, too, has the responsibility of putting shots together in such a sequence that these rules are observed, while still trying to make sense out of the overall meaning of the program. Good luck!

Cutaways and inserts

Often the availability of proper cutaway or insert shots is the only thing which saves the editor from, at best, profound frustration, or possible even insanity.

You see cutaways frequently in television news interviews. These are the shots of the interviewer looking at his notes, or nodding at what the subject is saying. Usually the cutaway shot has been used to cover up an edit in a continuous shot of the interview subject when removing a few words or sentences would otherwise have produced an unacceptable jump cut. As such, the cutaway is a valuable device, but it should be used with great discretion, as it looks rather contrived. (Often these shots are done after the interview is completed, and the interviewer isn't really reacting to anything - which often shows.) Over-the-shoulder shots are common too - and also often don't work because the sound is noticeably out of sync with the subject's body or facial movements.

It is also possible to cut away to other subjects, like the crowd reacting to a speaker's words, or a close-up of the subject's hands. These sometimes work well and can cover many otherwise embarrassing gaps in visual continuity. Insert shots have another function in that they actually contribute to the meaning of the program. Inserts are shots, or sequences, which usually show something that a speaker is talking about. While an interview subject describes a process, an insert sequence can be designed to show that process actually taking place. While these segments can be used to cover continuity difficulties they also tend to make a program more interesting and meaningful.

Achieving the proper balance between "people" footage (interviews and speakers) and "process" material is difficult, and of course depends on the nature of the specific program you are making. In general, though, it is better to show something than to talk about it; television is a visual medium and only by making use of its ability to show things as they actually happen can it truly be distinguished from radio or audio tape. Of course, there are programs where the emphasis is on the people involved as much as the things they are doing, and in these cases there is nothing more beautiful or interesting than the human face. So keep your purpose in mind when deciding on an overall plan for the editing of your programs.

Insert and cutaway footage is so important in editing that it is essential to be aware of the need to produce this type of material at the time of shooting. Many discontinuities are not the result of ignorance of the rules on the part of the editor, but happen simply because the required quantity or quality of insert material was never shot. Much of a good camera person's time is spent looking for and recording reaction shots and various close-ups and cutaways which can be used by the editor to cover any difficulties later. It is definitely something to keep in mind when you start to shoot tape.

Shot timing and pacing

The need to keep certain shots fairly short was discussed earlier. In general, close-ups do not hold interest as long as medium shots and it is uncommon to see any shot that lasts longer than about ten seconds, but certain types of action can be held longer if it seems appropriate. It is a good idea to vary the length of shots, particularly if many of your shots are fairly short, unless the building of a definite and predictable rhythm is what you have in mind.

One final note. Changes in shots that are too frequent and done for no apparent reason can be worse than long static shots. Editing should never be allowed to interfere with or distract from program content.

Cutting sound

In professional film editing, it is not considered much of a problem at all to restructure sentences or even words by precise editing to change the meaning of what someone says. Digital audio files and the audio portion of digital video files can be processed using computers to change not only the sequence of sounds, but volume, pitch, and other characteristics. Even so, most audio editing for video is restricted to making cuts between phrases or sentences, trying to fit together the sometimes random-sounding ramblings of your subjects into a smooth whole.

It is beyond the scope of this chapter to try to dictate how your subjects' thoughts should be fitted together, so we will concentrate on a few rules and suggestions as to how the continuity of sound fits into the overall production of a program.

Most programs of the informational or educational genre have their continuity dictated almost entirely by the content of the sound track. In fact, the spoken word probably conveys most of the actual information in most of the television programs you have seen.

This is a difficult problem, because errors in visual continuity (which is what most of this chapter has been about) are usually much more obvious and distracting to the viewer than a more abstract lack of logic or coherence in what the interview subjects or narrator say. So in many cases the content will have to be adapted to the needs of maintaining a smooth VISUAL flow. Cutting within interview footage, which is often necessary from a content perspective, almost always generates a visually offensive jump cut which requires a cutaway or something similar to reduce the distraction. Sometimes a dissolve or wipe can be used to soften a jump cut.

The use of sound other than voices should be considered. The natural sounds of many settings - chirping crickets or the cacophony of a factory - can be used to make some kinds of points more effectively than any narration. The use of music in setting moods is fairly obvious; indeed it is possible, and often very powerful, to edit the visual portion of a program to fit, in both rhythm and content, a prerecorded piece of music.

One technical detail about editing sound which seems relevant here involves the timing of different spoken segments to be edited together. In average conversation, most people pause about half a second between sentences. If you are trying to edit dialogue together so that it still sounds natural and flowing, you should try to maintain the time between utterances at about this figure. Most people do not pause noticeably between individual words, although a gap of a tenth of a second or so will go unnoticed if it doesn't occur too often. Naturally, these times have to be adjusted somewhat to fit the specific speech patterns of the individuals involved, so they are only a guide.

A second consideration in sound editing might be thought of as an audio jump cut. Every recording location has a characteristic sound, or presence which may even change slightly during different times of the day. People, too, vary the quality of their voices according to many conditions from stuffy noses to fatigue or emotion. Very few narrators can duplicate the sound of their own voices from one day to the next. Even though two sequences might be recorded using the same equipment in the same location, the quality of the audio may well be so different that a noticeable and objectionable change in sound occurs at an edit point. In editing narrative sequences, the speaking pace must also be fairly constant if the edit is to be "believable."

This barely begins to scratch the surface of the field of editing, yet the rules and ideas presented here are basic ones you will have to keep in mind while shooting and editing videotape. Watching television critically, with an eye toward the contribution of the editor to the finished program, then editing your own work, will teach you more about the craft than any stack of books could. Don't be afraid of all those buttons!

Videotape Editing

Video editing is the selective copying of material from one videotape (or computer file) to another. The process is entirely electronic. Nothing is cut, glued, or pasted. The original is not altered in any way by the editing process. Successful and efficient editing requires some specialized equipment, some knowledge of how the equipment works, and a great deal of planning and preparation both in shooting original footage and in editing itself.

Tape to tape editing

The necessary editing equipment includes two videotape recorders, two television monitors, and an edit controller. The original tape is played back on the source recorder, which is sometimes called the master recorder. This recorder must be designed to be run by remote control. The audio and video outputs of the source recorder are connected to the inputs on the editing recorder, sometimes called the slave recorder. The editing recorder, in addition to being operated by remote control, also needs some features not found on most videotape recorders. First, it must operate in sync with the playback recorder. That is, its internal timing circuits have to lock to the sync portion of the incoming composite video signal. Second, to make clean edits between old and new video, it must be able to go from the playback mode to the record mode and back only in the vertical interval, or the brief time between pictures. Finally, to accomplish this, it must have special erase heads, called "flying" erase heads, actually mounted on the video head assembly. Most videotape recorders have erase heads that are fixed and erase the entire width of the tape. Because the video signal is laid down on tape in long diagonal passes across the tape, the conventional erase head would erase portions of many frames of video. The erase heads mounted on the video drum can erase video one field at a time, allowing very clean transitions between old and new video.

The audio and video signals from each recorder are also connected to television monitors. This allows the operator to see and hear what is on either tape at any time. Finally, both recorders are connected to a compatible edit controller. The controller includes the basic transport controls for both recorders, such as fast forward, rewind, play, pause, and stop, plus special editing functions.

Editing modes:

In the ASSEMBLE mode it is assumed that there is nothing recorded on the edited videotape after the selected edit point. Each new sequence is edited onto the end of the previous sequence until the tape is completed. No picture or sound which might already have been on the tape is used.

In the INSERT mode, it is assumed that material already on the tape is to be retained. New material is inserted into old. Not all of the signals during the edit need to be replaced. The operator sets the editing machine to change the picture or either of the sound channels or any combination of the three. At the end of the edit, the recorder will return from the record mode to the playback mode.

The Control Track:

Almost all videotape recorders record and play back a special sixty hertz pulse called the control track. This track is used in playback to make sure the video heads are positioned correctly to read video information recorded on the tape. Any break in the control track, or sudden shift in phase, or loss of signal level will cause a videotape recorder to vary its speed until it returns to lock. This in turn usually causes the picture to break up or disappear entirely. The essential difference between the assemble and insert edit modes is that in the assemble mode new control track is recorded from the edit point on, while in the insert mode prerecorded control track is used and no new control track is generated. Therefore, the picture will always break up at the end of an assemble edit and, conversely, there must always be good continuous control track already on the tape throughout an insert edit or the picture will break up on later playback wherever the control track was flawed, even though no trouble was observed during the actual insert edit.

Many editors commonly in use are called control track editors because they use the control track as a reference for all of the editing functions. It is critical to know and understand this. Without a good and continuous control track from at least six seconds prior to an edit point to at least two or three seconds after an edit point it may be impossible to make an edit at all. Actual requirements vary from machine to machine, so it is advisable to make sure there is always at least ten seconds of control track in front of and behind every shot recorded.

SMPTE Editing:

The Society of Motion Picture and Television Engineers devised a special audio signal that can be recorded on tape and used to identify the location of each frame of video precisely. This SMPTE code is used in many edit suites for three reasons. First, edits using SMPTE code are frame-accurate and repeatable. Second, the code can be used to trigger events in other equipment, such as special effects generators, computers, and audio recorders. Third, preview copies of raw tapes can be made with the frame numbers showing on the screen, so you can make editing decisions "off-line." Most SMPTE code is recorded on a linear audio channel. That means you have to have two audio channels to use it. Three are better. Most one inch and many 3/4 inch VTR's have three audio channels, leaving two for program content.

SMPTE is not the only time code in use today. A number of companies have their own proprietary codes. They all serve the same purpose - allowing precise control over editing equipment.

Computer Editing

The rules for editing are the same for film, videotape, and computer editing. The medium changes, not the message.

In addition to playback and record VCR's, video monitors and audio gear, computer editing requires a computer that is fast enough and has enough memory to process video, a device to capture video and audio and turn them into computer files, and hard drives that are big enough and fast enough to handle all of the video and audio you will need to store. On Windows computers you want to make sure your capture drive uses the NTFS file format.

Editing video on a computer offers several advantages over using videotape. The first is the ability to change the content or length of any part of a program without having to re-edit everything from that point to the end. In computer editing you are constructing a list of instructions, describing how the program is to be assembled by the computer. Because you can work on any part of the program without adversely affecting subsequent parts, computer editing is commonly referred to as "non-linear editing."

A second advantage of computer-based editing is the ability to use more audio and video tracks. Tape-to-tape editing allows for only one or two video tracks and (for most systems) two monaural audio tracks. In theory, computer-based editors could have virtually unlimited audio and video tracks available. In practice, four or five video tracks and the same number stereo audio tracks are usually sufficient. On the video side, this allows the usual "A" and "B" video rolls, the transitions between the A and B rolls, a track for titles and other luminance or chroma keys, and even enough tracks to do a "quad split." Audio would generally consist of the location sound (two tracks to cross fade with the video transitions), the narration, and two music tracks (to cross fade between cuts).

A third advantage of computer editing lies in the ability to duplicate files without loss. As you move files from memory to a hard drive or to tape backup or to a CD or DVD-ROM and back again, there is no loss of quality. On the "down" side, video has to be "captured," or transferred from tape into the computer. Capturing is in itself an editing process. Clips have to be identified and transferred in real time. You might expect capturing to take up to twice as long as the total length of the video you are transferring even if the process is automated.

The way video is captured and stored in one editing system may not be compatible with another. In other words, while you can be sure that an NTSC VHS videocassette can be played back on any NTSC VHS machine, a

video computer file may not be readable by any software other than the software used to create it.

Almost all video on computers is "compressed." Uncompressed video is equivalent, more or less, to a 20 Megabytes per second data stream. The fastest "safe" video data rate for most hard drives is half of the tested sustained speed, or between two and eight Megabytes per second. Compression schemes that reduce the effective data rate to three to six Megabytes per second produce excellent video and manageable file sizes. For example, one hour of video at four Megabytes per second would fit on a fifteen gigabyte hard drive.

Depending on the sophistication of your editing hardware, some, most, or all, of the transitions, keys, and other effects you apply to clips in your editing program have to be created and saved on disk by the program before they can be viewed or played back. This process is called "rendering." It can be quite time-consuming, especially in low-end editing systems.

As far as creating a "first draft" is concerned, non-linear, or computer editing is not really any faster than tape-to-tape editing, especially when the time required to digitize clips is considered. It is much more powerful and more flexible.

The first step in nonlinear editing is capturing the source video and audio. There are, broadly speaking, two types of video; analog and digital.

Analog Video Capture

To capture analog video you will need a video capture card that can convert composite video or S-video to digital video. High-end cards may also be able to convert component video to digital. Some capture cards convert both audio and video and some rely on your sound card to handle the audio.

The conversion process may be carried out entirely by the hardware on the card, or by software running on your computer, or by some combination of both. In general, hardware conversion is more reliable than software conversion. On windows computers the digital conversion product is generally an AVI file. An AVI (Audio Video Interleaved) file is a sound and motion picture file that conforms to the Microsoft Windows Resource Interchange File Format (RIFF) specification. MacIntosh files conform to their Quicktime format. In either case, the converted file is almost always compressed. That is, much of the picture information is truncated or discarded according to a compression scheme called a codec. If the file format is dependent on hardware on the capture card or deviates from one of the generally accepted codecs your ability to play back files will be limited. Do not assume that all AVI files are alike in the way that all VHS tapes are alike. They aren't.

Most capture cards do not compress audio. In fact, rather than using the 44100 Hz sample rate found on commercial CD audio disks, audio for video is sampled at 48000 Hz. That equates to 1.536 Mbps.

You probably will not be able to monitor audio or video levels on the computer as your video is captured. If possible, you should use a time base corrector and waveform monitor to make sure the signal going to the computer meets broadcast standards. Although some capture cards have time base correctors built in, most do not.

It is not sufficient to monitor the audio input, since the computer has software audio level and balance controls.

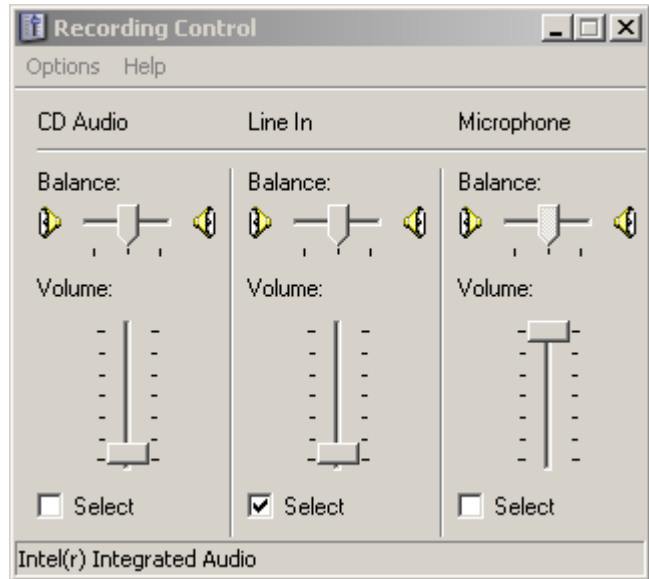

Audio Recording Control

In general, the audio signal can be recorded only if “line in” is selected in the audio recording window. This is true whether or not playback of “line in” is muted. Use an audio recording program to verify the presence of the signal and to check the loudest part of your program.



These programs will show you a graphic representation of audio amplitude in real time. Set the incoming audio at zero VU if you can, then adjust the line in record level to make sure the loudest audio on your tape is not “clipped.” The dynamic range from noise to clipping is so great in digital audio that there is no excuse for clipping a digital audio signal. Only when you are satisfied that the record audio level is correct should you begin the capture process.

Among the options you can select in most capture programs is the division of the source video into discrete clips. When capturing composite or S-Video, the capture program attempts to detect scene changes by measuring the difference between frames. You may also be able to set an arbitrary interval and create a new clip, for example, every ten or twenty seconds. There are two types of clips. In some programs each clip is a separate file. In others the captured video is a single file with software-defined clips. You should consider your application before using video clip detection. If, for example, you are going to be making minor changes to an event video you would not want to have to re-assemble the event from a large number of discreet clips. On the other hand, if you are looking for short segments from your tape to be used in another program or you need to alter the sequence of events, clip detection can be very helpful.

Your digital recording will never be better than the tape you digitize. Because of the rapid degradation of the quality of the tape signal from one generation to the next you should make every reasonable effort to digitize the original raw video and audio.

Except in rare cases you will not have computer control over your video playback machine. You will have to start the tape machine and the digitizing process separately. Some capture programs will detect absence of video. Some will wait to begin digitizing until the video signal amplitude is greater than color black. Your goal should be to start digitizing before any useful

video or audio begins and, obviously, to stop within five or ten seconds of the end of your material. You are going to be consuming enormous chunks of hard drive. You don't want to waste it with color black or snow.

You can estimate the amount of disk space you will need. At 4.5 MBps for audio and video you will use 270 MB per minute and 16 GB per hour of recording. Your digital file may hang around on your hard drive for weeks or months.

Digital Capture

Digital capture is a much simpler process than analog capture. The most common digital recording format is "DV." This format is already digital and already compressed to about 4 MB/sec and already compatible with the Microsoft AVI format. To move it to your computer you need to connect your camcorder or DV recorder to your computer using the IEEE-1394 Interface, also called "FireWire." There is no loss of audio or video quality in the transfer. That is the good news. The bad news is that there is no way to adjust the video (level, setup, chroma, hue) or audio (level, balance, equalization).

Capture software for digital transfer generally offers the additional advantage of "machine control." The playback device can be controlled by the computer. DV tapes can have two different times embedded in the video signal. One is zeroed at the beginning of the recording and shows the time on tape. It can be displayed on the camcorder monitor in the upper right hand corner. Your capture software depends on the tape time recorded on your DV tape. If that signal is not continuous it will zero itself and start over. This is confusing for people. It is fatal for some digital capture software, since tape times are not unique and the software uses the machine control interface to search the tape for specific time points on the tape.

DV tapes can also have a digital time stamp that records the actual date and time each frame is recorded. Clip detection can be based on the digital time stamp on the tape. A discontinuity in the time stamp indicates the tape was stopped and restarted, ending one clip and beginning a new one. It may also be possible to detect clips by looking for sudden changes in video content. Whether you want to detect clips depends on how your software treats clips and the nature of your project.

With the exception of very high-end systems, nonlinear editing systems use AVI or Quicktime files that are compressed from 20 MegaBytes per second down to around 4 MB/sec. One CDR will hold about three minutes. One DVD-R will hold about 16 minutes per layer.

Television Production Manual

Getting the word out

Videotape

VHS videotape is still a viable distribution option preferred for audiences that are resistant to change.

CD

There are several ways to distribute video on CD's. They have been especially popular as a medium for motion pictures using the MPEG 1 standard. The quality of these "video CD's" is about the same as VHS. Some DVD authoring software can be used to make CD's that behave like DVD's. The total run time for these disks is about fifteen minutes. The special software needed to play back the CD content is included on the disk. These CD's are for computer CD/DVD drives only and are generally programmed to run the software automatically when the disk is inserted. While this is a viable way of distributing DVD-quality video to computer users, its usefulness diminishes as new computers are delivered with DVD drives as standard equipment.

It is also possible to make CD data disks that contain MPEG 2 or Windows Media Format files. Most computers now have the codecs needed to play MPEG 2 or WMF files. Again, at about four Mb/Sec a CD can hold about fifteen minutes of video. The increased compression of the WMF format allows more than sixty minutes on one CD. The WMF format fits the specifications for MPEG 4, the compression regimen designed to accommodate high definition television. Both Quicktime and Real Player also offer compressed video formats that can be included on data CD's. The appropriate players will have to be downloaded by your viewers.

Finally, there is software available for authoring data CD's, or CD-ROM's. These software packages allow the integration of files on the disk with files on the internet in addition to many of the navigation features common to DVD's.

DVD

One popular way to distribute video is the DVD. A DVD is an optical disk, actually a reflective film sandwiched between two protective acrylic layers, like a CD, but with some differences. The most important difference is that a typical DVD can hold up to 4.7 GB of data, including formatting information on a single layer disk and twice that on a dual layer disk. You have roughly four gigabytes of space available for project on a single layer disk.

There are two ways of using DVD technology to distribute video. The traditional method is to use DVD authoring software to create a DVD that can be played on a stand-alone DVD player, typically called a “set top” player. Set top players require a specific MPEG 2 format which makes it nearly impossible to reverse-engineer the video for editing. This DVD format is ideal for distribution. In small quantities you can make your own DVD’s with relatively inexpensive software and hardware. Color printers capable of printing directly on the DVD face are very affordable as well. It should be noted that from the beginning there have been problems with compatibility between DVD-R and DVD+R disks and some set top DVD players, especially models made before 2001.

For large quantities you’ll want to use a commercial disk replicator. Replication is a two step process. First a glass master disk is made. Then the master disk is used to press or stamp a reflective disk, which is then sandwiched between two acrylic layers for protection. The minimum cost for replication is usually the same as the cost of making 800 to 1000 copies. In other words, whether you ask for one hundred, two hundred, or a thousand copies of your masterpiece, the total cost of replication (not including album cases or other packaging) will be about the same.

Most commercial disk replicators will now accept a DVD-R as a master, although the preferred medium for mastering DVD’s is DLT, or digital linear tape. DLT was developed to backup or archive computer networks and servers. If you want digital copy protection for your DVD’s you will have to submit your masters on DLT.

When dealing with a commercial replicator, be prepared to be able to prove you have the right to use all of the audio and video on your disk. Replicators do not like to be sued.

Making a DVD

A DVD can be as straightforward as a videotape. Pop it in the player and the program runs from start to finish with no embellishments. Or it can have a complex system of menus allowing the viewer to select various programs or go to specific points within programs. Menus can allow viewers to select different audio channels or call up subtitles.

The first step in making a DVD is to assemble all of your finished media as digital files. There are only limited opportunities to edit materials in DVD authoring software. It is best if all of your materials are in final form before you go any further. Audio files should be in the .wav format. Your video files are probably either Quicktime or .avi files. They must be converted to MPEG 2. This option should be available in your video editing software. If you have optional audio tracks you can convert your video using your primary mix of audio tracks, then save your secondary mix of audio tracks separately as a .wav file. You can do this by turning the appropriate tracks on or off before exporting the file. In addition, you may have still images you want to use in your DVD, perhaps as menu backgrounds or buttons. Full frame stills should be 640x480 pixels for NTSC or 640x576 for PAL. Your DVD authoring program will change these stills, which have square pixels, to 720x480 or 720x576 pixels where the width of each pixel is nine tenths of the height. The difference is pixel aspect between digital stills and digital video affects all of your still images, whether full frame or smaller.

Your authoring software will allow you to import video, audio, and still image files. The categories may be straightforward or have more imaginative names, such as “Media,” “Backgrounds,” and “Buttons.”

At this point it may or may not tell you if your project will fit on a DVD. You have about four gigabytes available. If your project is too large you can go back to your video editing software and change the MPEG 2 conversion settings to increase the compression and decrease the file size of each MPEG 2 file. While the DV files you generally work with in your editing software are compressed to about four Megabytes per second, MPEG 2 files are generally compressed to from 3.5 to 8 Megabits per second. At the lowest compression you have a little over an hour of video on a DVD. At the highest compression you can get about two hours on a disk. As you increase the compression of your video files you also increase the chance that you will lose detail in your video during quick movements. The loss of detail will take the form of pixilation. Your video will be reduced to a jumble of blocks until the

rate of video change returns to a more normal rate. You should probably keep your data rate at four megabits per second or higher.

There is actually more to the MPEG 2 format than the data rate. While in the DV format compression is achieved frame by frame, MPEG 2 is divided into groups of pictures (GOP's) usually twelve to fifteen frames long. The first frame (I) of each GOP has all of the information necessary to reconstruct the frame. The remaining eleven to fourteen frames (P and B frames) contain only enough information to reconstruct the video by combining information from previous frames (P frames) or by combining information from both previous and following frames (B frames).

The best consumer authoring programs will allow you to import your video and use it to create all of your menus and buttons in a very straightforward and intuitive way. Typically, once you've imported your video clips you can select one of several menu styles. If you have more than one video clip, you can assign each clip to a button on the menu. You may even be able to create intermediate menus and use the time line of your video you can select chapter points and drag those points to menu buttons. In some cases the video from the clip will form a still image in the button automatically. When you're done you usually have at least two options: burn one or more DVD's using the current project settings, or create a file that is an exact image of the contents of the DVD. When you burn your DVD's from the current project your program will create a temporary file on your hard drive in which all of your materials are converted into the required DVD format. Your disks are burned from the temporary file, which is deleted as soon as the disks are done. When you elect to create an image file, the file is created on your hard drive but no disks are burned. You can use the image file to burn your disks later as you need them.

Professional software will allow you to do anything you'll see on a commercial DVD. Professional software is not, as a rule, either user-friendly or intuitive. It is more powerful and flexible.

The Internet

Using video on the internet creates a set of considerations and problems that should be part of the video planning process before any video is shot. The basic fact about the internet is that it was never designed to transmit video and audio at four megabytes per second or even four megabits per second. To send video over the internet more compression is necessary.

There are several compression schemes for internet video that rely on four ways of reducing picture information.

1. They generally reduce the frame size.

2. They reduce the frame rate.
3. They reduce the amount of information in each frame beyond the compression available in MPEG 2 by sacrificing picture quality when content in moving and maintaining higher resolution when images are relatively still.
4. They “buffer” the bit stream.

Reducing the frame size reduces the amount of picture detail available and should be an important consideration in shooting for the internet.

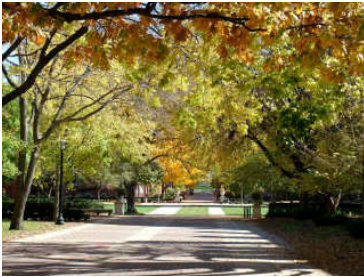

640x480 pixels

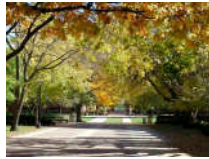

320x240 pixels

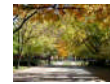

160x120 pixels

Loss of detail can turn excellent images into mud. Just as commercial motion pictures are often shot not for the resolution available with 35mm film, but with the more limited resolution of NTSC video in mind, you should shoot for resolutions much lower than standard video.

After decades of experimentation the film industry settled on a few frame rates. For silent consumer film either sixteen or eighteen frames per second was used. There was a noticeable flicker when films were projected at these rates. Commercial sound motion pictures are projected at twenty-four frames per second. The frame rate for NTSC television is thirty frames per second. Frame rates for streaming video are often below fifteen frames per second. The impact on motion is obvious. At fifteen frames per second, how many frames does it take to swing a baseball bat?

The third method of reducing the data rate, sacrificing detail during motion sequences, further “muddies” the picture. Motion and fine detail are mutually exclusive in the world of streaming video.

Buffering can be as simple as actually downloading the entire video at one rate in order to play it back on a computer at the designed normal rate. More commonly, playback is delayed until enough data has been downloaded to allow playback of a significant part of the video. When the playback catches up with the download (and runs out of data to play) the playback is paused until more data is downloaded. This process often causes awkward pauses during playback, but that’s progress.

Streaming video should accommodate a range of users, from those with 56 Kbps dial-up modems to those with DSL and cable modems receiving in excess of one gigabit per second at the modem (but less than 54 Mbps over their wireless network). When you export video from your editing software you will have the option of two or three streaming formats. Pick the one you believe will offer your viewer the best picture quality, given the content of your video) with the least inconvenience and delay. Each of these will in turn allow you to choose either a single streaming rate or multiple rates dependent on the viewer's reception rate.

All that's left to be done is to move the finished streaming video file onto a web site for downloading.

Archiving your work

Most of the time most artists want their work to last at least as long as they live. Throughout recorded history we have been able to save some pieces of art or literature on cloth, paper, stone, or metal. Each of these has properties that cause the information to degrade, but all have one thing in common: It does not take any equipment beyond the human eye to recognize and read the information, although the eye may need a brain behind it trained in hieroglyphics or ancient Greek.

Times have changed. Your hardware may become obsolete or even incompatible with newer operating systems. Changes in the computer world have given an entirely new meaning to the word "legacy." Until recently the word referred to property inherited or traditions passed down from one generation to the next. In the computer world "legacy" has become an adjective referring to the data in any application that can no longer be used by readily available software or hardware. The 5 ¼ inch floppy disk is a legacy system in that no computers sold today can read those disks. The 3 ½ inch floppy disk is pretty close to legacy status itself. As you move from one operating system to the next or from one capture card to a different brand you risk rendering all of your .avi files unreadable. Keep the tape. And while you are at it, take very good care of your playback equipment, too.

So far we've gone through the following videotape formats: Two-inch quad, one inch helical of various formats up through type C, half-inch EIAJ reel to reel, U-Matic and U-Matic SP, Betamax, VHS, Betacam and Betacam SP, M2, S-VHS, 8 Millimeter, and Hi-8 analog formats; DV, Digital 8, DV Cam, DV Pro, Digital Betacam, a more. If your tape is stored properly at moderate temperature and humidity you are more likely to have trouble finding playback equipment than you are to have trouble with the videotape itself.

Television Production Manual

The best you can do is to make copies of your work in the highest quality digital format you believe has a user base large enough to keep it in use for a long period of time and that you can afford. While many are choosing to “archive” their work on DVD in MPEG 2, that medium is much more highly compressed than the DV format, which is in general use and slowly replacing both VHS and 8mm as the recording format of choice, both by amateurs and many professionals. For works under fifteen minutes DV files can be stored as .avi or .mov files on DVD-R disks without further compression. A dual layer writable disk could hold up to thirty minutes. With the advent of high definition video there is no way to know how long the equipment to play back standard definition tapes will be generally available, while current DVD drives and both blue laser disk formats can play material on existing DVD-R disks. Properly stored DVD-R disks should last at least one hundred years, while rewritable disks can be expected to last at least twenty-five years. Considering the formats and equipment in common use twenty-five years ago, you should be prepared to re-record your work to new formats as it becomes advisable or necessary.

Television Production Manual

Glossary

A.

AC. Alternating Current. Electrical current that changes polarity regularly and continually.

Access Channel. One of the three cable channels designed for use by the public, government, or education.

AGC. Automatic Gain Control.

Ambient sound. Unintelligible background noise found in and generally unique to an audio environment.

Amp. Ampere. Unit of electrical measure equal to one volt sent through a resistance of one ohm. Also one watt divided by one volt.

Amphenol connector. A threaded connector sometimes used for unbalanced microphone lines.

Amplified. Any electronic device used to increase the level or power of signals applied to it.

Aperture. Any electronic device used to increase the level or power of signals applied to it.

Aperture. Opening in camera lens controlling and allowing light to pass through.

ASA. American Standards Association. A unit measuring the sensitivity of photographic emulsions. The higher the ASA number, the more sensitive the emulsion.

ASCAP. American Society of Composers, Authors and Publishers.

Assemble edit. A video editing procedure which records new video, audio, and control track information simultaneously without reference to any signal already on the tape.

Attack time. The response time of an automatic gain control circuit to rapidly increasing signals.

Attack time. The time the rotating video head actually contacts the videotape and begins to write or read video information.

Audio. Sound.

Automatic Gain Control. Electronic circuit designed to keep signals at an acceptable level by amplifying signals that are too low and attenuating or reducing signals that are too high.

Available light. Light from a natural source or commonly used lamp, as opposed to light added to a scene by using special photographic or television lights.

AWG. American Wire Gauge. A unit of measure of the cross sectional diameter of wire. The higher the number, the thinner the wire. Ordinary lamp wire is 18 AWG.

B.

Back focus. The distance from the rear element of a lens to the image plane.

Background light. Any light used to illuminate the background of a set or scene, but not intended to illuminate the subject.

Backlight. Light striking a subject from the direction opposite to the camera. Generally used to highlight the subject and set it apart from the background.

Balanced line. A cable carrying two equal signals of opposite polarity on separate conductors, both surrounded by a grounded shield.

Bandwidth. The amount of audio or radio spectrum required or used by a signal or waveform.

Barn door. A metal flap or group of metal flaps attached to the front of a lamp housing to prevent light from spilling outside a desired area.

Base light. An even, diffuse, light filling a setting with sufficient light to keep shadows from key or back lights from being too dark.

Base video. A video signal that is not combined with a carrier to place it in the radio frequency spectrum. Normally has an amplitude of one volt peak to peak across an impedance of 75 ohms.

Bayonet mount. A lens mount, or electrical connector which engages by means of interlocking fingers and cams and permits attachment with only a relatively small amount of twisting action.

Beta format. A group of videotape formats similar to U-matic used with half inch color videocassette recorders and players.

Betacam. A component broadcast system using half-inch tape and cases similar to those for the Beta format.

Bi-directional microphone. A microphone designed to pick up sound on two sides of the microphone along the same axis, but reject sound from any other direction.

Bloom. A loss of picture detail and increase in size of bright portions of a video picture seen when too much light is allowed to strike a pickup tube or when the signals controlling a tube allow it to be overdriven.

BMI. Broadcast Music, Incorporated. A music licensing service.

BNC connector. A connector with a bayonet lock used with coaxial video cable.

Boom microphone. Any microphone, but usually a unidirectional or shotgun microphone, attached to a pole or boom to keep the microphone near an audio source but outside of the field of view.

Broad. A light with a long bulb perpendicular to the direction in which the light is aimed, designed to throw an even light with an indistinct shadow.

Brightness control. A control used to adjust the illumination of viewfinders, monitors, and receivers, but not affecting signal levels from cameras or other picture sources.

Television Production Manual

Burn. Part of a pickup tubes that has a depletion of charge evidence by a negative image of the picture source causing the depletion. This condition is temporary unless the tube is turned off and allowed to cool before the problem is corrected.

Burst. A gated 3.58 megahertz signal immediately following horizontal sync and used as a reference in controlling the hue, or phase, of color signals.

C.

Cable. The electrical cords used to interconnect pieces of audio and video equipment.

Cable. A term generally referring to a broadband distribution system using wire rather than over-the-air broadcast.

Camera cap. A cap screwed or mounted onto the front of a camera in place of the lens to protect the camera pickup tube from light or dirt when the lens is not in place.

Cannon. A three-pin connector used with balanced audio lines for line and mic level audio signals. Also known as an XL or XLR connector.

Capacitor. An electrical device which stores energy as an electrostatic charge. Often used as a component in filter circuits.

Capstan. The spindle that actually drives tape across head assemblies.

Cardioid microphone. A somewhat unidirectional microphone with a heart-shaped pickup pattern.

Carrier. The RF signal which is modulated by a video or audio signal for broadcast transmission.

CATV. Community Antenna Television. Broadband distribution system using coaxial cable rather than over-the-air broadcast.

CCD. Charge-coupled device. In television, the device that senses light coming through the lens and translates it into electrical impulses (replacing the pickup tube).

CCU. Camera control unit.

CD. Compact disk. Laser disk with five inch diameter, which may contain video, audio, or data in digital format.

CD ROM. Compact disk with digital data used with a computer as "read-only memory."

CG. Character Generator.

Character generator. A small computer used to generate titles and other text electronically without the use of a camera.

Characteristic impedance. The apparent resistance to an alternating current shown by a wire or electronic device.

Chroma. The characteristic of a color which refers to its saturation or intensity. Also the color pattern of the television signal.

Chroma key. A key based on the chroma saturation and hue of portions of a picture, rather than on the luminance, or brightness. A specific hue is replaced by one picture source, while the rest of the picture is replaced by another picture source. A chroma key is an external key.

Television Production Manual

Chrominance. The color portion of the television signal.

C-mount lens. A lens with a standard one-inch threaded mount assembly that is screwed into the camera body, as opposed to a bayonet or "m" mount.

Close-up. A shot emphasizing detailed elements in a scene, as opposed to the more panoramic wide view.

Coaxial cable. A cable having a center conductor surrounded by insulation and a grounded shield.

Codec. Compression/expansion scheme for compressing audio or video files for storage, then expanding to original size for playback.

Color killer. A circuit designed to detect the presence of burst in a television signal and deactivate the color circuits if the burst signal is low or absent.

Compatible. Meeting all of the electronic requirements for signals and levels necessary to interface devices to achieve desired results.

Condenser microphone. A microphone using a power supply (usually a battery) to maintain a charge across two plates which modulate a voltage when the distance between them changes.

Confidence head. A video head separate from the normal record/play head found on some videotape recorders and used to monitor the actual recorded signal on the videotape during recording.

Contrast. The difference in illumination between the brightest and darkest parts of a scene or picture.

Contrast control. A control used to change the amplitude of the video signal in viewfinders receivers, and monitors, but not affecting the output of cameras or other video sources.

Control track. A reference signal recorded on videotape and used to control the path of the video heads across the tape on playback.

Credits. Listings of all those involved in making a program, usually appearing at the end of a television program or film.

Critical focus. The plane in front of a focused lens in which the image will be precisely in focus on the film or pickup tube.

CU. Close-up.

Cume. The total audience size (number of viewers) for a program or series of programs over several showings. Repeat viewers are not counted.

Cut. The instantaneous transition from one picture or audio source to another.

Cutaway. A shot interposed at an edit point to prevent the appearance of a jump cut at the edit point.

Cyclorama. A seamless background, blending into the floor and usually lit from behind. Used to eliminate any background detail from a set.

D.

DA. Distribution Amplifier.

dB. Decibel. A unit used to compare the relative levels of electrical signals on a logarithmic scale. The formula for the calculation is $db=10(\log(P2/P1))$, or $db=20(\log(E2/E1))$.

Television Production Manual

Demodulation. The process of separating a signal from its carrier frequency.

Depth of field. The range of distances in front of the lens in which objects appear to be in acceptable focus.

Depth of focus. The range of distances from the rear of the lens to the face of the pickup tube in which acceptable focus can be achieved.

DIN. A type of multi-pin connector.

DIN. A standard for film sensitivity similar to ASA. Not Direct Current. An electrical current that does not change polarity.

Dissolve. The gradual change from one picture to another, allowing the pictures to be superimposed during the transition.

Distribution amplifier. An amplifier with essentially unity gain used to distribute control and picture signals to equipment in a television system.

Distortion. Any undesirable alteration in an audio or video signal.

Dolly. A wheeled device attached to a tripod to allow smooth movement of a camera.

Dolly. A camera movement toward or away from the subject (dolly forward, dolly back).

Dub. To copy by playing back on one machine and recording on another.

Duct tape. A shiny adhesive tape designed for holding metal heating and cooling ducts, but also commonly used as a substitute for gaffers tape, a general purpose tape used in television and film.

Dynamic microphone. A microphone which uses a magnet moving in a coil of wire to generate an electrical signal.

E.

Edit. In television, to record from any program source altering the duration or temporal sequence of events using a recorder specifically designed to do this efficiently and cleanly, maintaining continuity of sync and proper timing relationships between signals at edit points.

EIA. Electrical Industries Association.

EIAJ. Electrical Industries Association of Japan. Universal standard for video recording in black and white on half inch reel-to-reel videotape recorders. The standard involves a tape speed of 7 1/2 inches per second with a sixty-minute capacity using a seven inch reel. There is only one audio channel.

Eight-pin. A common rectangular connector generally used between television monitors and videotape recorders combining all of the cable connections necessary for record and playback functions into a single connector.

EFP. Electronic Field Production.

Electret. A type of condenser microphone.

Electronic Field Production. (EFP) Production of a television program or program segment by recording material on location with a single camera and editing this material to make the finished product.

Television Production Manual

E to E. Electronics to Electronics. Refers to the normal record mode in a videotape recorder in which the recorder output is connected to the recorder input and cannot show the actual signal recorded on tape. Some videotape recorders have special confidence heads which allow direct tape monitoring during recording. Most do not.

Equalization. Changing the relative balance of frequencies in an audio or video signal.

Equalizing Pulses. A series of sync pulses within the horizontal interval which determine the starting point for the first scan line of each field of video.

Establishing shot. A shot used to introduce a scene, including a relatively wide angle of view and showing the relationships between objects, settings, and people in the scene.

F.

Fade. The gradual change from one picture or sound source to another. Usually to or from black (video) or silence (audio).

F connector. A small threaded connector used with coaxial cable in the RF distribution of television signals.

Fidelity. A subjective appraisal of the amount of distortion in the reproduction and transmission of signals.

Field. One scan from the top to the bottom of the television frame, tracing alternate horizontal lines and taking one sixtieth of a second to complete.

Fill light. Light used to fill in shadows left by key light and keep the contrast range of a scene within the capabilities of the recording medium.

Film chain. An equipment grouping including a dedicated camera, super 8mm and 16mm projectors, dual dissolving 35mm slide projectors, and a special rotating mirror assembly (multiplexer) which transmits the images from one of the projectors to the dedicated camera.

Filter. A flat piece of glass or gelatin with no optical properties other than to control the color or intensity of light.

Filter. An electrical device used to reduce the transmission of signals in some frequency ranges and allow transmission of signals in other frequency ranges.

Flag. Temporary persistence of a bright spot on the pickup tube as the image causing the spot is moved across the face of the tube.

Flag. The horizontal shift observed at the top of the screen when a timing error occurs due either to skew and tension problems on playback or to slight timing errors at an edit point created in the editing process.

Flag. A metal flap used near a lens to keep lights from shining directly into the lens and causing lens flare.

Flare. An undesired image, or overall haziness of an image caused by undesired reflections of light from surfaces within the lens itself.

Flat. A framed upright panel, usually 4 x 8 feet or larger, used to simulate a wall or wall section in a television set.

Flat response. The reproduction or transmission of a signal with very little deviation from the original amplitude of the signal over its entire frequency range. Deviations in amplitude are expressed in db, plus or minus.

Flood light. Any light throwing a broad, even illumination in a circular pattern with diffused shadows.

Flutter. A form of signal distortion caused by rapid fluctuations in the speed of a tape crossing a head assembly.

Flying erase head. An erase head mounted on the rotating video head drum in advance of the record/playback head.

Focal length. The distance from the optical center of a lens to the focal plane.

Focal plane. The plane perpendicular to the lens axis at which parallel rays striking the lens are converged to a point.

Focus. To cause a sharp image from a lens to be projected onto the focal plane (in the case of a camera) or onto a screen (in the case of a projector). Also to adjust the electron beam converging circuits in a television monitor for maximum sharpness as they strike the surface of the picture tube.

Foot candle. The amount of light produced by a standard candle at a distance of one foot. The most common unit of measure for incident light used in film and television work.

Frame. A complete television picture consisting of two interlaced fields of video. The frame rate for NTSC television is thirty frames per second.

Freeze frame. The continuous repetition of a single frame of video. It is technically not possible for helical videotape recorders to display freeze frames, since they read only one field of video on each pass across the videotape.

Frequency. The rate of repetition of an electrical or audio signal, expressed in Hertz (cycles per second).

Fresnel. A special light-weight lens used in focusing beams of light.

Originally used in lighthouses, now also used in high-quality studio and theatrical lights.

f-stop. The size of the aperture in a lens, given in f-numbers. The lower the f-number, the more light passes through the lens. It is the ratio of the lens focal length to the actual diameter of the aperture opening. See T-stop.

Fuse. A device designed to interrupt an electrical circuit in the event of an overload of that circuit.

G.

Gaffer. The crew member principally responsible for transporting, maintaining, and setting up lighting equipment.

Gaffer's tape. A strong adhesive tape used in film and television production.

Gain. Degree of amplification. The difference between the signal level at the input of a device and the level at the output, usually expressed in dB.

Generation. The number of duplication processes by which a videotape is removed from the live source. The original recording is first generation, while a copy of an original recording is second generation, and so on.

Television Production Manual

Genloc. To reference a signal generator to a signal normally external to and separate from the system controlled by the signal generator. The purpose is to bring a system, such as a studio, into proper timing with an external source, such as a live remote camera, so that special effects as wipes, keys, and dissolves can be done using the external source in combination with internal sources.

Grip. The crew member principally responsible for the transportation, maintenance and mounting of the camera.

Ground. A connection to the chassis or a common return path, or an actual connection to the earth in an electrical device.

H.

Head. The camera without lens or viewfinder.

Head. The uppermost portion of a tripod or pedestal which provides for the ability to pan and tilt the camera.

Head. A small electromagnet with a very small air gap between the poles used to record and play back magnetic pulses on audio or video tape.

Head gap. The space between the poles of a head. Good frequency response is dependent on proper width of the head gap. Dirt or oxide particles clogging a head can cause reduced signal level and distortion of the signal.

Head room. The space between the top of a subject's head and the top of the video frame.

Helical. Like a helix. Specifically, the geometric pattern formed by a rotating video head in relation to videotape moving across the rotating head assembly. Thus, referring to any videotape recorder using a rotating head assembly that reads a complete field of video on each pass across the tape. These include all EIAJ, U-matic, Beta, and VHS formats as well as one-inch SMPTE types A, B, and C.

Hertz. Cycle per second.

Heterodyne. A system used for recording color video signals at a reduced frequency.

High level. Audio signal intended to attain a maximum, or peak, level of zero db, or one volt at six hundred ohms impedance. (0.775 volts rms.)

Hiss. The background noise generated in an audio system which is internally generated by microphones, amplifiers, and tape.

Horizontal hold. An adjustment on viewfinders, monitors, and receivers to make the frequency of the horizontal sweep circuits to the horizontal sync pulse from an incoming signal.

Horizontal sync. That portion of the sync signal that controls the horizontal timing (and therefore horizontal location) of each line of picture.

Hue. Shade of color, determined in television by the phase angle between a color and the color subcarrier or color burst reference signal.

Hum. Unwanted low frequency audio noise caused by improperly shielded or improperly grounded audio cables and circuits.

I.

Television Production Manual

Impedance. The apparent resistance to an alternating current shown by a wire or electronic device.

Impedance matching. The use of a transformer or other device to alter the impedance of a device to equal the impedance of another device. Minimum distortion and loss of signal can be achieved only where the output transmitting a signal, the cable carrying the signal, and the input receiving the signal all have the same impedance.

Incident light. Light striking a subject, as opposed to light reflected by a subject. Usually measured in film and television by light meters calibrated in foot candles.

Insert. A shot or sequence inserted into a television program used to illustrate a subject.

Insert edit. A video or audio edit made with reference to pre-recorded control track so synchronization is maintained and the insert can be ended without visible disruption of the picture.

Interlace. The process of combining the two video fields into frames by writing only even-numbered lines in one field and only odd-numbered lines in the other.

Internal sync. Synchronizing signals generated by a camera, recorder, or other picture source without reference to or need of external synchronizing signals.

IRE. Institute of radio engineers. NOW IEEE. Also a unit of measure of video amplitude. One IRE unit is equal to 1/140 volt, peak to peak. The composite video signal is composed of sync, from -40 to 0 IRE and video, from 0 to 100 IRE. Black is normally set at between 7.5 IRE and 10 IRE.

J.

Jump cut. An edit made without regard to the thirty degree rule, which results in a visual discontinuity as subjects appear to "jump" on screen.

K.

Key. A video special effect in which the level of a video signal is used as a switch which allows selective substitution of picture information from one source with picture information from a different source. Luminance keyers use the amplitude of the monochrome portion of the signal, while chroma keyers use the amplitude of a specific color or hue. Most printed material is inserted into video using luminance keys, while picture information is inserted using chroma keys.

Key light. The primary illumination for a scene, generally giving the impression of a natural light source and throwing the darkest and most defined shadows in a scene.

Keystone. The effect of projecting an image onto a surface that is not perpendicular to the axis of the projecting lens. Parallel lines tend to converge in the direction where the surface is closer to the lens.

L.

Television Production Manual

Lag. The tendency in some camera pickup tubes to retain an image after it is no longer presented to the tube. This effect is most evident when a relatively bright image is replaced by a darker field of view and is aggravated when a bright image is stationary in the field of view for an extended period of time before it is replaced.

Latent image. The image retained by a pickup tube after the source of that image is removed. If a latent image is present on a pickup tube when a camera is turned off, the image may be permanently fixed on the tube.

Lavalier. A microphone worn on the body and held in place either with a lanyard worn around the neck or a clip fastened to clothing. The frequency response of a lavalier microphone is skewed toward the higher frequencies to compensate for the low frequency sound transmitted directly to the microphone by contact with the body.

Lens hood. Also lens shade. A cone fastened to the front end of a lens to keep incident light from striking the lens elements and causing lens flare.

Limiter. An amplifier designed to limit or compress signals over a desired level, thus reducing the chances of distortion and keeping the range of signal levels within the range that can be recorded. Unlike an automatic gain control, a limiter does not augment or boost low levels.

Line level. In audio, a signal with a peak power of about one milliwatt at an impedance of 600 ohms, or zero dBm. This is equivalent to a voltage of .775 volts rms. Also known as "high level" or "auxiliary level."

Live. Not prerecorded. Occurring at the same instant as it is seen or recorded.

Live card. A card, usually about 11 x 14, used in television to display text or graphics to a camera.

Live on tape. Unedited. Recorded exactly as occurring with no compression of time or alteration of any sequence of events.

Long shot. A shot including a relatively wide view of an overall scene, often used as an establishing shot.

Low level. Microphone level. An audio signal with a maximum level of about minus fifty dB, relative to line level, or 2.45 millivolts at 600 ohms impedance.

Lux. The amount of light produced by a standard candle at a distance of one meter.

M.

Master. A control uniformly governing the outputs of a number of other controls.

Master. Sometimes in editing, the source, or playback, machine.

Master. The finished copy of a program from which copies are made for distribution.

Matching transformer. A transformer used to alter the impedance of a signal source to match the input impedance of another device. A common use of matching transformers is to change the characteristic impedance of a 75 ohm

coaxial antenna cable to 300 ohms to match the antenna input of a television set.

Medium shot. (MS). A shot showing a single subject, rather than an overall scene, but not in detail. For example, a shot of a person including the body from the waist to slightly above the top of the head.

Mic mouse. A soft foam pad or holder for a microphone which is placed on a stage or studio floor. The mic mouse holds the microphone very near the floor without allowing it to touch. The purpose is to eliminate the effect of sound waves bouncing off the floor and interfering with sound waves transmitted directly to the microphone.

Mixer. An electronic device for combining the outputs of several sound sources, with separate control over the volume or quality of each.

Modulation. The process of varying the instantaneous amplitude, frequency, or phase of a carrier signal in response to the waveform of an information-bearing signal.

Multiplexer. A device which uses a movable mirror to select images from one of several optical sources for transmission to the dedicated camera in a film chain.

N.

Neutral Density Filter. A filter having no effect on color and no optical effect on the lens to which it is attached, but which reduces the overall amount of light reaching the lens. A one power filter reduces transmission by half, or by one f-number. A two power filter reduces transmission by two f-numbers.

Noise. Any unwanted signal interfering with the clarity and intelligibility of desired signals. The background of static inherent in any recording or amplifying device, generally forty to sixty db below the peak output level of the device.

Nose room. The space between the nose of a subject's head in profile and the edge of the video frame the subject is facing.

NTSC. National Television Systems Committee. Referring to any standard for signals devised by that body, such as NTSC color bars or NTSC sync. The television system used in the United States, Canada, Japan, Central America, and a number of other countries. The NTSC system has 525 interlaced horizontal lines and 30 frames per second. [Look for countries using NTSC.](#)

Nuvidicon. A type of video pickup tube used in inexpensive color television cameras.

O.

Octave. A doubling of frequency. Almost all audio devices have a sound frequency range of from four to ten octaves. A piano, with 88 keys, has a range of seven and a third octaves. A video signal has a range of almost twenty octaves.

Omnidirectional microphone. A microphone which picks up sound equally well from all directions.

Television Production Manual

Optical Viewfinder. A camera viewfinder which has no electronics and therefore cannot reflect the actual picture being transmitted from the camera. Optical viewfinders for inexpensive television cameras are rangefinder viewfinders which are separate from the camera lens system and show a picture slightly different from that seen by the camera. The difference is most troublesome for subjects close to the camera where the angle of difference, or parallax, is greatest.

Original. Usually first generation audio or videotape from which a master is made.

One-hundred eighty degree rule. A rule of visual continuity which states that when dealing with two or more subjects, shots may only be cut together if they are taken from the same side of a line drawn through the subjects. Used to maintain proper direction on the screen.

P.

PAL. Phase Alternating Line. The television system used in western Europe, China, and most of the rest of the world. The PAL system has 625 interlaced lines and 25 frames per second. [Look for countries using PAL.](#)

Pan. A camera movement in which the camera is rotated in the horizontal axis. The proper commands are "pan right" and "pan left."

Parabola. A parabolic dish used to reflect sound waves, concentrating them on a microphone, allowing sound to be picked up from greater distances than with even a normal unidirectional or shotgun microphone.

Parallax. The difference in view caused by looking at a scene from two slightly different locations.

Patch bay. Patch panel. A control panel where all the video and audio lines used in a studio are brought together and terminated in connectors allowing any combination of lines to be wired together as desired by patching in short lengths of cable.

Patch cord. A short cable with connectors used to interconnect lines in a patch panel. Any audio or video cable used for temporary connections.

Peak to peak. Literally, encompassing the entire waveform from the most negative part to the most positive. One of two ways to measure signal amplitude, the other being rms (root mean square). Peak to peak measurements are usually more meaningful in video, while rms is more meaningful in audio.

Pedestal. A camera support generally restricted to studio use having a single elevator column mounted on a tricycle base.

Pedestal. Also called setup. The black level in a television picture, 7.5 to 10 IRE units above sync. Per cent modulation. The amount of amplitude of a signal in terms of the maximum amplitude that signal can be allowed to achieve.

Phase. The difference, expressed in degrees, in the instantaneous amplitude of two signals of the same frequency.

Phase. The difference, expressed in degrees, between two signals. In color television, the angle between the burst reference signal and any color or hue.

Phone jack. An audio connector generally used with unbalanced lines and intercom systems. Phone jacks may have a single conductor with ground (unbalanced lines) or two conductors with shield (intercom systems and stereo headphones).

Photoflood. Any of a number of lamps designed for still photography that throw an even, diffuse light. They may be designed to fit into a dish reflector or have internal reflectors. Since they are ordinary tungsten bulbs, they tend to lose output power and change color temperature with age, making them unsuitable for color television.

Pickup tube. A light-sensitive electron tube which is scanned by an electron beam to convert an image focused on the face of the tube into an electronic signal.

Pixel. The smallest indivisible area of a computer display that can be addressed.

Plumbicon. A pickup tube used in almost all tube-type broadcast color cameras.

Pop. Microphone distortion caused by speaking certain consonants (especially "p") into a microphone placed too close to the mouth.

Portapak. A brand name for a battery-operated portable video camera and recorder combination.

Pot. Potentiometer. A variable resistor used to control the level of a signal.

Preamp. An amplifier used to increase signal levels prior to additional processing.

Presence. The ambient sound found in and unique to a recording location.

Proc amp. Processing amplifier. Separates the video signal into sync and picture components to allow limited adjustment of pedestal, gain, and some other aspects of the picture and recombination with internally generated sync signals.

Profile. Side view, especially of a person.

Proximity effect. An overemphasis of low-frequency tones caused by speaking too close to a unidirectional microphone.

Q.

Quad. Broadcast videotape recorder having four rotating video heads, each of which reads only 17 horizontal lines of picture per pass over the tape. Quad recorders use two-inch videotape.

Quartz-halogen. The light of choice in color television, designed to maintain correct color temperature and uniform output throughout its life. Provides much higher output than conventional tungsten light of the same power consumption and has a life up to one hundred times that of common tungsten photographic lights. These lamps are sensitive to shock and handling and should never be touched with bare hands.

R.

Television Production Manual

Radio Frequency. (RF) That part of the frequency spectrum in which it is possible to radiate (transmit) electromagnetic waves. Any part of the broadcast band, including radio and television.

Radio mic. Transmitter mic or wireless mic. A microphone connected to a small radio transmitter, used in situations where cables would be cumbersome or impossible to use. FCC regulations are stringent in the use of transmitter microphones.

Rating. The percentage of the total potential television homes tuned to a specific program. Because the rating is based on total television homes, including those that are not watching any television, the totaling one sixtieth of a second to complete.

RCA pin plug. A small connector used with unbalanced single conductor shielded audio cables to interconnect home entertainment audio products. Also used as high level inputs and outputs on some video recorders and audio mixers. Also called a phone plug.

Receiver. Any device capable of demodulating an RF signal, such as a radio, tuner, or television set.

Recorder. Any device that converts an electronic signal to a magnetic pattern in the oxide coating of a magnetic tape.

Recorder. In editing, the videotape recorder or machine on which the edited tape is compiled.

Reel-to-reel. Any audio or videotape format which uses tape packaged on open reels which must be threaded manually, rather than enclosed in a cassette or cartridge.

Reflected light. Light reaching the camera after being reflected by a subject. Measured in candles per square foot.

Reflector flood. A sealed floodlight with a self-contained reflector.

Reflector spot. A sealed spotlight with a self-contained reflector.

Release time. The response time of an automatic gain control circuit to rapidly decreasing signal levels.

Remote. A production at a location other than a television studio using a special effects generator and other equipment associated with multiple-camera studio facilities.

Resolution. The degree to which fine detail can be recorded or displayed. In film, measured in pairs of light and dark lines per millimeter. In television, measured in lines per scan. Thus, the horizontal resolution of a television camera would be measured by the number of discernible vertical lines that could be displayed across the width of the screen.

RF. Radio frequency.

RF modulator. A device used to convert a signal to a form similar to that transmitted by an over-the-air broadcast so the output can be used by standard receivers.

RF splitter. A passive device used to distribute radio frequency signals to two or more receivers.

Television Production Manual

Riser. A platform on which talent sit or stand, used to raise the talent to a level more suited to coverage by the television camera.

rms. Root mean square. A measure of the effective level of an audio signal or alternating current.

Roll-off. The gradual reduction of frequencies above or below a certain point. Filters which roll off the bass frequencies are often included in unidirectional microphones to compensate for proximity effect.

ROM. Read only memory. Computer memory that can be read, but cannot be overwritten by the host computer.

Rover. A brand name for a battery-operated portable video camera and recorder combination.

rpm. Revolutions per minute.

S.

Safe area. In television graphics or film shot for television, the area which is almost certain to be displayed on any television set. About 80% of the scanned area.

Saticon. A television pickup tube used mostly in industrial television and electronic news gathering.

Scanned area. In television graphics, the area on a slide or live card which is to be scanned by the television camera. This area is about 25% larger than the safe area.

Scrim. A wire mesh used to reduce and soften the light from a light.

SECAM. Sequential Color with Memory. The color television system developed in France using 25 frames per second and 625 horizontal lines.

[Look for countries using SECAM.](#)

SEG. Special Effects Generator. The device in television used to switch between and combine various picture sources. Also called a switcher.

Sensitivity. The ability of a device, such as a camera or microphone, to sense intelligible information and convert it into a usable electronic signal.

Servo. An electronic circuit used to control the speed of a motor which drives a videotape recorder head assembly drum, which must be controlled with great precision.

Share. The percentage of the total television sets in use that are tuned to a specific program.

Shield. The outer metal portion of a shielded or coaxial cable, normally grounded, to protect conductors from interference.

Shock mount. A support for a microphone which used rubber or foam supports to isolate the mic from vibrations which can appear as low frequency rumble in the audio.

Shotgun microphone. A unidirectional microphone with a narrow pickup pattern.

Sibilance. An undesired hissing sound resulting from over emphasis of high-frequency sound in the reproduction of "s" and "z" sounds in speech. Reduced by equalization or use of a windscreen.

Television Production Manual

Signal Generator. A device used to generate electronic test signals and, in television, the drive and synchronizing signals used to control and time components in a television system.

Signal to noise ratio. The difference in amplitude between unintelligible noise and the maximum signal output of a device.

Skew. In television, the tendency of a picture to hook at the top of the television screen and the control found on some videotape recorders which adjusts tape tension in order to correct this picture problem.

Slave. In some editing systems, the record machine, or the machine on which the edited tape is compiled.

Slow motion. Playback of a film or videotape at a speed slower than the speed at which it was recorded. This is impossible to do in all but a few specialized videotape recorders without sacrificing picture stability.

SMPTE. Society of Motion Picture and Television Engineers. An organization devoted to the standardization of equipment and practices.

SMPTE leader. The leader with the eight second count-down commonly used in film.

SMPTE Type A, B, or C. The standards for one inch videotape recorders.

Type C is the preferred standard for broadcast one inch videotape.

Source. Any piece of equipment which transmits information to another piece of equipment. Usually referring to devices attached to the input ports of audio mixing consoles, special effects generators, or recorders.

Special Effects Generator or SEG. The device in television used to switch between and combine various picture sources.

Splitter. A passive device used to distribute RF signals. **Spotlight.** A light having a narrow beam that casts well- defined shadows.

Subcarrier. The 3.58 megahertz signal used in generating and controlling the hue of NTSC color television signals.

Superimposition. The adding or mixing of two video signals to produce an image with two or more pictures visible simultaneously. Used when a keyer is not available to add graphics to video. Sometimes used to refer to a key.

Switcher. Also special effects generator or SEG. The device in television used to switch between and combine various picture sources.

Sync. Any of the signals used to generate and control a television picture, but, specifically, the portion of the composite video signal from zero to minus forty IRE units consisting of vertical and horizontal timing pulses and equalizing signals to maintain the proper relationship of the two fields of video making up each frame.

Sync defeat. A switch on videotape recorders that use the composite video signal at the video input to control the internal timing of the recorder which interrupts that control function, allowing the recorder to control timing functions without reference to the incoming video signal.

Synthesizer. A device used to generate video signals without a camera, used in the production of graphics.

T.

Take. The instantaneous transition from one picture source to another. A cut.
Target Voltage. The voltage applied to the pickup tube which determines the sensitivity of the tube to light.

TBC. Time base corrector.

Telephoto lens. Any lens with a focal length significantly greater than the standard focal length for the format in which it is to be used. The standard length for 35mm still cameras and one inch television cameras is 50mm.

Thirty-degree rule. A principle of visual continuity which states that the relative angle of view of any two similarly framed shots of the same subject which are to be cut together should vary by at least thirty degrees.

Tilt. A camera movement in which the camera is rotated in the vertical axis. The commands are "tilt up" and "tilt down."

Time base corrector. A highly specialized device with the primary function of making the unstable video output of a videotape recorder conform to the rigid timing of a signal generator, allowing videotape to be used as a picture source in combination with other sources driven by the signal generator.

Titles. Graphic information appearing at the beginning of a program, generally including the title, author, producer, writer, director, and major personalities.

Tracking control. The control used to maintain alignment of the video head with the tracks of video information on a tape.

Tracking head. The magnetic head that writes and reads a sixty hertz pulse on videotape. During playback this pulse is used to maintain proper alignment of the video heads with the tracks of video information on a tape.

T-stop. Similar to an f-stop, this is a number which indicates the effective aperture opening of a lens after compensation is made for the amount of light lost due to internal absorption and reflection. The T-number is always larger than the corresponding f-number.

Tuner. The demodulator section of a radio, television set, or videotape recorder.

U.

UHF. Ultra High Frequency. Radio frequencies from 300 to 3,000 megahertz.

UHF. A television broadcast band consisting of channels 14 through 83.

UHF connector. A threaded video connector used with coaxial cable.

U-matic. The standard format for 3/4 inch videocassette recorders. This format has a maximum record/play time of one hour and two discrete audio channels.

Unbalanced line. A cable with a single signal-carrying conductor and a grounded shield.

V.

Vectorscope. A special type of oscilloscope designed to display the saturation and hue of chroma signals in a polar pattern. This device is essential in the

Television Production Manual

evaluation of color signals when aligning color picture sources or matching and timing color sources in a television system.

Vertical hold. A control on television monitors, viewfinders, and receivers used to control the frequency of the vertical oscillator and allow the vertical sweep circuits to lock to the vertical sync component of an incoming video signal.

Vertical interval. The period of time between the last line of a field and the first line of the next field.

Vertical interval switching. Switching based on circuits that delay switching from one picture source to another until the picture source being switched to is between fields, or in the vertical interval.

Vertical interval editing. Use of a videotape recorder which is capable of recording and erasing video field by field (has a "flying" erase head) and employs vertical interval switching at the edit point.

VHF. Very high frequency. Radio frequencies from 30 to 300 megahertz.

VHF. The television broadcast band having television channels 2 through 13.

VHS. A half inch videocassette format using the "M" wrap tape path. Not compatible with the BETA format.

Video. The picture portion of a television signal, sometimes referred to as "composite video" when both picture and sync signals are present.

Videocassette. A container holding both the feed and take-up reels which is inserted into a videotape recorder and threaded automatically.

Vidicon. A type of television pickup tube common in inexpensive cameras and still used to some extent in broadcast cameras.

Volt. The standard unit for measuring the difference of potential between two points in an electronic circuit.

VTR. Videotape recorder.

VU. Volume unit. Unit of measure of complex waveforms such as audio signals.

W.

Watt. Unit of electrical power equal to one volt across a resistance of one ohm, or one volt at a current of one ampere.

Waveform monitor. A specialized oscilloscope designed to display the video waveform with great stability and high resolution. Essential in determining and setting correct levels for the luminance (monochrome) and sync portions of the composite video signal and useful in evaluating critical timing relationships.

Wide angle. Any lens with a focal length significantly less than the standard length for the format in which it is used. For 35mm still cameras and one inch television cameras, the standard length is 50mm.

Wide Shot (WS). A picture showing a subject in the context of the surroundings to establish the relationship between the subject and the surroundings.

Television Production Manual

Wind screen. A thin soft foam cover for microphones which reduces the noise made by wind striking the microphone.

Wipe. The transition between television picture sources in which each picture source is displayed on only a portion of the screen, that portion being determined by an electronically generated pattern which can be sized and positioned using a special effects generator.

Wow. The slow fluctuation in speed of a transport mechanism which results in low frequency instability and distortion in playback of an audio or video tape.

X.

XL. Also XLR or cannon. A three-pin audio connector used with balanced lines in microphone and line level audio applications.

Z.

Zoom. To change the focal length of a zoom lens.

Zoom lens. A lens with a variable focal length.

Zoom ratio. The ratio of the longest focal length to the shortest focal length of a zoom lens.